

BT5525

Instruction Manual

BATTERY INSULATION TESTER



**Read carefully before use.
Keep for future reference.**

✓ When using the instrument for the first time

- Safety Information ▶ p.12
- Part Names and Functions ▶ p.18
- Test Flow ▶ p.24



Troubleshooting

- Troubleshooting ▶ p.195
- Error ▶ p.197

EN



Contents

Introduction.....	7
Checking Package Contents.....	8
Options.....	9
Symbols and Abbreviations.....	10
Safety Information	12
Precautions for Use.....	14
1 Overview	17
1.1 Product Overview	17
1.2 Features.....	17
1.3 Part Names and Functions	18
1.4 Screen Configuration and Operation Overview	21
Measurement screen	21
Setting screen	22
1.5 Test Flow.....	24
2 Test Preparation	25
2.1 Inspecting the Instrument before Test	26
Checking the insulation resistance test.....	27
2.2 Supplying Power to the Instrument.....	28
Connecting the power cord	28
Turning the instrument on and off	29
2.3 Connecting the Test Leads.....	30
2.4 Connecting a Communications Cable.....	30
2.5 Connecting the Test Leads to the Device Under Test (DUT)	31
2.6 Shutting Down the Output of the Instrument (Interlock Function).....	32
3 Basic Settings	33
3.1 Setting the Test Voltage.....	34
Setting the test voltage in the Measurement screen	34
Setting the test voltage in the Setting screen	35
3.2 Setting the Range (Auto/Manual).....	36
Setting the test voltage in the Measurement screen	36
Setting the test voltage in the Setting screen	37
3.3 Setting the Sampling Time	38
3.4 Setting the Measurement Delay Time.....	39
3.5 Setting the Test Time and Comparator Delay Time.....	40
Setting the time during which a test voltage is applied	40
Setting the comparator delay time	41
3.6 Judging the Measured Value (Comparator Function).....	44
3.7 Setting the Test Mode	46
3.8 Notifying the Judgment Result and Test Completion with a Beep	47
4 Test Method	49
4.1 Starting a Test	49
4.2 Display during a Test.....	51
4.3 Displaying the Measured Value	52
4.4 Memory Function.....	53
4.5 Ending the Test	55
4.6 Discharging Residual Electric Charge (Auto Discharge Function)	56
5 Various Functions	57
5.1 Checking for Any Contact Defects and Confirming Contact Condition (Contact Check Function)	58
5.2 Detecting Micro Insulation Failure (BDD Function)	60
Enabling the BDD function and setting the threshold value	61
Enabling the BDD stop function.....	62
Enabling BDD judgment.....	63
5.3 Limiting the Current to Be Applied to the Device Under Test (DUT)	64
Setting the current limit value manually.....	65
Setting the current limit value automatically	66

- 5.4 Setting Whether to Turn ON or OFF the Key Operation Sound.....67
- 5.5 Enabling/Disabling the Key Operations.....68
 - Disabling the key operations (key lock).....68
 - Enabling the key operations (releasing key lock).....68
 - Enabling the key lock function with a passcode.....69
 - Disabling the key lock function with a passcode.....70
 - Releasing the key lock by entering the passcode.....71
- 5.6 Adjusting the Screen Contrast.....72
- 5.7 Adjusting the Backlight73
- 5.8 Manually Setting the Frequency of the Power Supply74
- 5.9 Initializing the Instrument (Reset)75

6 Saving and Loading Measurement Conditions (Panel Save and Load Functions) 77

- 6.1 Saving Measurement Conditions (Panel Save Function)78
- 6.2 Loading Measurement Conditions (Panel Load Function)79
- 6.3 Changing the Panel Name80
- 6.4 Deleting Panel Data81

7 External Control (EXT. I/O) 83

- 7.1 External Input and Output Terminals and Signals.....85
 - Switching the current sink (NPN) and current source (PNP)85
 - Connector used and signal arrangement ...85
 - Signal functions86
- 7.2 Timing Chart.....87
- 7.3 Internal Circuit Configuration91

- NPN setting91
- PNP setting92
- Electrical specifications93
- Connection examples93
- 7.4 Checking External Control95
 - Input/output test (EXT. I/O test function)95
- 7.5 Accessory Connector Assembly Procedure96
- 7.6 Using Analog Output.....97
 - Connecting an output cord98

8 Communications Function 99

- 8.1 Interface Overview and Features100
 - Remote state and local state100
- 8.2 RS-232C Interface.....101
 - Setting communications conditions.....101
 - Connecting the RS-232C cable102
- 8.3 LAN Interface103
 - Settings for the communications conditions104
 - Setting the communications conditions106
 - Setting the LAN communications.....108
 - Enhancing the speed of LAN communications.....108
 - Connecting a LAN cable109
- 8.4 USB Interface.....110
 - Installing the USB driver.....110
 - Connecting the USB cable110
- 8.5 Automatically Sending the Measured Value Every Time a Test Is Completed (Auto Data Output Function).....111
- 8.6 Communications Command Display (Command Monitor Function).....112
- 8.7 Communications Method.....114
 - Message format.....114
 - Output queue and input buffer119
 - Status system119
 - Standard Event Status Register121
 - Items restored to the default settings123
- 8.8 Communications Command List124
- 8.9 Communications Command Reference130

Introduction

Thank you for choosing the Hioki BT5525 Battery Insulation Tester. To ensure your ability to get the most out of this instrument over the long term, please read this manual carefully and keep it available for future reference.

The latest edition of the instruction manual

The contents of this manual are subject to change, for example as a result of product improvements or changes to specifications.

The latest edition can be downloaded from Hioki's website.

<https://www.hioki.com/global/support/download/>



Product registration

Register this product in order to receive important product information.

<https://www.hioki.com/global/support/myhioki/registration/>



Refer to the following instruction manuals in accordance with your application.

Name of the instruction manual	Description	Format
Instruction Manual (this manual)	Includes overview of the instrument, operation methods, function descriptions, and specifications.	PDF file (for web download)
Startup Guide	Includes information for using the instrument safely, basic operation methods, and specifications (selected relevant information).	Hard copy
Operating Precautions	Information for using the instrument safely. Please review the separate "Operating Precautions" before using the instrument.	Hard copy

Intended audience

This manual has been written for use by individuals who use the product or provide information about how to use the product.

In explaining how to use the product, it assumes electrical knowledge (equivalent of the knowledge possessed by a graduate of an electrical program at a technical high school).

Trademarks

Microsoft, Windows, Visual Basic, Visual Studio, Visual C++, and Visual C# are either registered trademarks or trademarks of Microsoft Corporation in the United States and other countries.

Checking Package Contents

When you receive the instrument, inspect it to ensure that no damage occurred during shipment. Pay particular attention to included accessories, panel keys and switches, and terminals. If you find any damage or discover that the instrument does not perform as indicated in its specifications, please contact your authorized Hioki distributor or reseller.

Confirm the package contents.

- BT5525 Battery Insulation Tester



- Power cord



- Startup Guide
- Operating Precautions (0990A903)
- EXT. I/O connector (male)

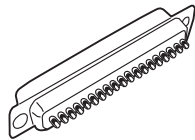

- EXT. I/O connector cover

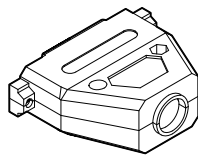

- EXT. I/O interlock cancellation jig

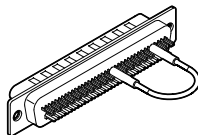

Options

The options listed below are available for the instrument. To order an option, please contact your authorized Hioki distributor or reseller.







Options are subject to change. Check Hioki's website for the latest information.

Model name	Rated voltage	Rated current	Cable length
L2130 Clip Type Lead (red) 	500 V	50 mA	1.5 m
L2131 Clip Type Lead (black, special triaxial connector) 	500 V	50 mA	1.5 m
L2132 Unterminated Lead (red) 	500 V	50 mA	5 m
L2133 Unterminated Lead (black, special triaxial connector) 	500 V	50 mA	5 m
L9094 Output Cord (analog output) 	30 V	0.5 A	1.5 m
L9637 RS-232C Cable (9-pin to 9-pin) 	–	–	3 m









Symbols and Abbreviations

Safety



In this manual, the risk seriousness and the hazard levels are classified as follows.

 DANGER	Indicates an imminently hazardous situation that, if not avoided, will result in death or serious injury.
 WARNING	Indicates a potentially hazardous situation that, if not avoided, could result in death or serious injury.
 CAUTION	Indicates a potentially hazardous situation that, if not avoided, could result in minor or moderate injury or potential risks of damage to the supported product (or to other property).
IMPORTANT	Indicates information or content that is particularly important from the standpoint of operating or maintaining the instrument.
	Indicates a high-voltage hazard. Failure to verify safety or improper handling of the instrument could lead to electric shock, burn injury, or death.
	Indicates a prohibited action.
	Indicates a mandatory action.

Symbols on the product

	Indicates the presence of a potential hazard. For more information about locations where this symbol appears on instrument components, see "Precautions for Use" (p. 14) and warning messages listed at the beginning of operating instructions, and the accompanying document entitled "Operating Precautions."
	Indicates that dangerous voltage may be present at this terminal.
	Indicates the ON side of the power switch.
	Indicates the OFF side of the power switch.
	Indicates direct current (DC).
	Indicates alternating current (AC).
	Indicates a grounding terminal.
	Indicates a ground terminal connected to the chassis of the instrument.

Symbols for various standards

	Indicates that the product is subject to the Waste Electrical and Electronic Equipment (WEEE) Directive in EU member nations. Dispose of the product in accordance with local regulations.
	Indicates that the product complies with standards imposed by EU directives.

Others

*	Indicates additional information is described below.
(p.)	Indicates the page number to reference.
[]	Indicates the names of user interface elements on the screen.
MENU (Bold letters)	Indicates the names of the control keys.

Accuracy labeling

The instrument's accuracy is expressed using a combination of the formats shown below.

- These formats define limit values for errors using the same units as measured values.
- They define a percentage of the reading, a percentage of full scale, a percentage of the setting, or a limit value for errors in terms of digits.

Reading (display value)	Indicates the value displayed by the instrument. Limit values for reading errors are expressed as a percentage of the reading (“% rdg.”).
Full scale (maximum display value)	Indicates the scale length or maximum display value for each measurement range. Measurement range values for the instrument indicates that scale length or maximum display value. Limit values for full-scale errors are expressed as a percentage of full scale (“% f.s.”).
Setting (setting)	Indicates the voltage and current values specified to be output from the measuring instrument. Limit values for setting errors are expressed as a percentage of the reading (“% of setting”). Indicates the voltage, current, or other value that the instrument has been configured to output. Limit values for setting errors are expressed as a percentage of the setting
Digit (resolution)	Indicates the minimum display unit (in other words, the smallest digit that can have a value of 1) for a digital measuring instrument. Limit values for digit errors are expressed using digits. Indicates the minimum display unit (in other words, the smallest digit that can have a value of 1) for a digital measuring instrument. Limit values for digit errors are expressed using digits

Safety Information

This instrument is designed to conform to IEC 61010 Safety Standards and has been thoroughly tested for safety prior to shipment. However, using the instrument in a way not described in this manual may negate the provided safety features.

Carefully read the following safety notes before using the instrument.

DANGER

- **Familiarize yourself with the instructions and precautions in this manual before use.**



Failure to do so could cause improper use of the instrument, resulting in serious bodily injury or damage to the instrument.

WARNING

- **If you have not used any electrical measuring instruments before, you should be supervised by a technician who has experience in electrical measurement.**



Failure to do so could cause the operator to experience an electric shock. Moreover, it could cause serious events such as heat generation, fire, and an arc flash due to a short-circuit.

Measurement categories

IEC 61010 defines measurement categories to facilitate safe use of measuring instruments. Test and measurement circuits designed to be connected to a main power supply circuit are classified into three categories depending on the type of main power supply circuit.

⚠ DANGER

- **Do not use a measuring instrument for measurements on a mains circuit that exceeds the range of the measurement category rated for the instrument.**



- **Do not use a measuring instrument without a measurement category rating for measurements on a mains circuit.**

Failure to observe this can cause a serious bodily injury and damage to the instrument and other equipment.

Measurement category II (CAT II)	Applicable to test and measuring circuits connected directly to utilization points (socket outlets and similar points) of a low-voltage MAINS installation. Example: Measurements on household appliances, portable tools, and similar equipment, and on the consumer side only of socket outlets in the fixed installation.
Measurement category III (CAT III)	Applicable to test and measuring circuits connected to the distribution part of the a building' s low-voltage MAINS installation. Example: Measurements on distribution boards (including secondary meters), photovoltaic panels, circuit breakers, wiring, including cables, bus-bars, junction boxes, switches, and socket outlets in a fixed installation, as well as equipment for industrial use and some other equipment such as stationary motors with permanent connection to the fixed installation.
Measurement category IV (CAT IV)	Applicable to test and measuring circuits connected at the source of the a building' s low-voltage MAINS installation. Example: Measurements on devices installed before the main fuse or circuit breaker in the building installation.

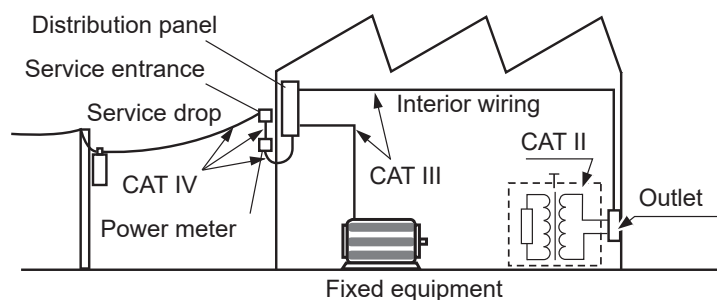

Precautions for Use

Be sure to follow the precautions listed below in order to use the instrument safely and in a manner that allows it to function effectively.

Use of the instrument should conform not only to its specifications, but also to the specifications of all accessories, options, and other equipment in use.

Installing the instrument

WARNING

■ **Do not install the instrument in locations such as the following:**

- In locations where it would be subject to direct sunlight or high temperatures
- In locations where it would be exposed to corrosive or explosive gases
- In locations where it would be exposed to powerful electromagnetic radiation or close to objects carrying an electric charge
- Close to inductive heating devices (high-frequency inductive heating devices, IH cooktops, etc.)
- In locations characterized by a large amount of mechanical vibration
- In locations where it would be exposed to water, oil, chemicals, or solvents
- In locations where it would be exposed to high humidity or condensation
- In locations with an excessive amount of dust



Doing so could damage the instrument or cause it to malfunction, resulting in bodily injury.

CAUTION

■ **Do not place the instrument on an unstable stand or angled surface.**



Doing so could cause the instrument to fall or overturn, resulting in bodily injury or damage to the instrument.

To prevent overheating, be sure to leave the specified clearances around the instrument.

- Place with its bottom side facing downward.
- Do not block vent openings.

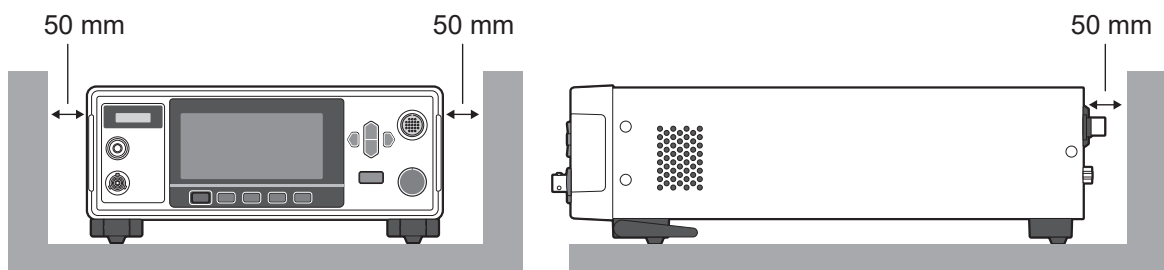

Check before use

DANGER

- **Inspect the instrument and verify proper operation before use.**

Use of the instrument while it is malfunctioning could result in serious bodily injury. If you find any damage, contact your authorized Hioki distributor or reseller.

Handling the instrument

CAUTION

- **Do not subject the instrument to vibration or mechanical shock while transporting or handling it.**



- **Do not drop the instrument.**

Doing so could damage the instrument.

- **Do not short-circuit the output terminal or input a voltage to the output terminal.**

The instrument is classified as a Class A device under the EN 61326 standard.

Use of the instrument in a residential setting such as a neighborhood could interfere with reception of radio and television broadcasts. If you encounter this issue, take steps as appropriate to address it.

Shipping Precautions

Store the instrument packaging material after opening the instrument. Use the original packaging when shipping the instrument.

Hioki cannot be responsible for damage that occurs during shipment.

Handling the test leads

DANGER



- **Do not use test leads whose insulation is damaged or whose metal portion is exposed.**

Doing so could cause serious bodily injury.

WARNING



- **When using the instrument while connected to test leads, use the lower of the ratings indicated on the instrument and on the test leads.**

Using the instrument to make measurements that exceed either rating could cause the operator to experience an electric shock.



- **When using this instrument, use only Hioki specified test leads.**

Using a test lead other than the specified parts could result in bodily injury or a short-circuit.

CAUTION

- **Do not step on cords or allow them to become caught between other objects.**

Doing so may damage insulation, resulting in an electric shock.

- **Do not bend or pull on cables at temperatures of 0°C or lower.**



The cable is hardened. Doing so could damage the insulation or cause a wire break, resulting in an electric shock.

- **Do not bend, pull on, or twist cables, including where they connect, with excessive force.**

Doing so could cause a wire break.

1.1 Product Overview

This instrument is an insulation resistance tester that generates DC voltage and tests the insulation resistance of instruments, parts, batteries, etc.

It's capable of high-speed testing using user-configured test voltages. With the Break Down Detect (BDD) function, micro short circuits and contaminations (metal foreign substances) can be detected during an insulation resistance test before battery liquid injection. In addition, this instrument can be widely used from manufacturing/test lines for research and development since ample communications interfaces are provided as standard equipment.

1.2 Features

● **BDD function for detecting micro insulation failure, contamination, etc. (p.60)**

Any small change to the voltage and current during a test can be captured and micro insulation failure due to contamination can be detected.

● **High-speed test**

Test results are displayed within 2 PLCs + calculation time at full speed.

● **Flexible test settings**

Measurement and charging current limit function (p.64)

Since the charging current can be limited as desired from 50 μ A to 50 mA, settings can be adjusted to yield the optimal test time for the device under test (DUT) that has a capacitive load.

Test voltage (p.34)

Any test voltage can be set between 25 V and 500 V with a resolution of 1 V. With the comparator function (p.44) and test time function (p.40), insulation resistance tests can be performed based on various standards.

● **Contact check function for detecting contact defects and broken connections of wiring (p.58)**

The contact condition is checked by monitoring the electrostatic capacitance between test points. This function helps improve the test quality.

● **Automatic discharge function (p.56)**

After the test, the electric charge stored in the DUT is discharged inside of the instrument, which can prevent any damage to other instrument at the next test.

● **Wide range of communications interface choices**

LAN, RS-232C, and USB connections are provided with the instrument as standard equipment. A personal computer (PC) and programmable logic controller (PLC) can be connected to import the instrument controls and test results. In addition, an EXT. I/O connection is also installed and the controls of the measuring instrument, instrument status, and judgment results can be imported.

1.3 Part Names and Functions

Front

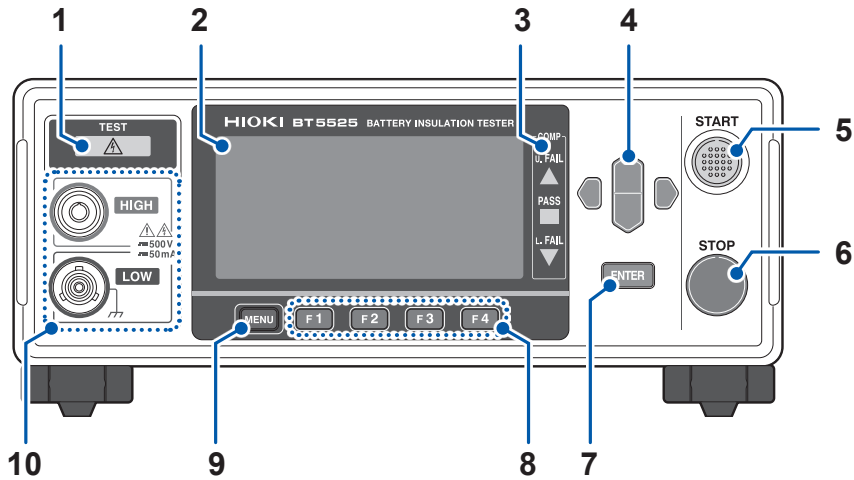

1	TEST indicator	Lights up when a hazardous voltage is applied to the measurement terminals.	p.49
2	Display	Monochrome graphic LCD	p.21
3	COMP lamp	Displays the judgment result of a measured value when the comparator function is selected. <ul style="list-style-type: none"> U. FAIL Measured value > Upper limit value PASS Lower limit value ≤ Measured value ≤ Upper limit value (within the judgment reference) L. FAIL Measured value < Lower limit value 	p.44
4	Cursor key	Moves over the items displayed in the screen display.	–
5	START key	Starts an insulation resistance test.	p.49
6	STOP key	Stops the insulation resistance test. Cancels the configuration process and returns to the measurement screen.	p.55
7	ENTER key	Confirms the items displayed in the screen display.	–
8	F key	Selects the items displayed in the screen display.	–
9	MENU key	Displays the setting screens and switches the page.	–
10	Measurement terminals	Connects a test lead.	p.30

This instrument can be mounted on a rack. Keep any parts removed from the instrument in a safe place in case you need to use them again.
See “11.7 Rackmount Fittings” (p.211) , “11.8 External View” (p.213)

Rear

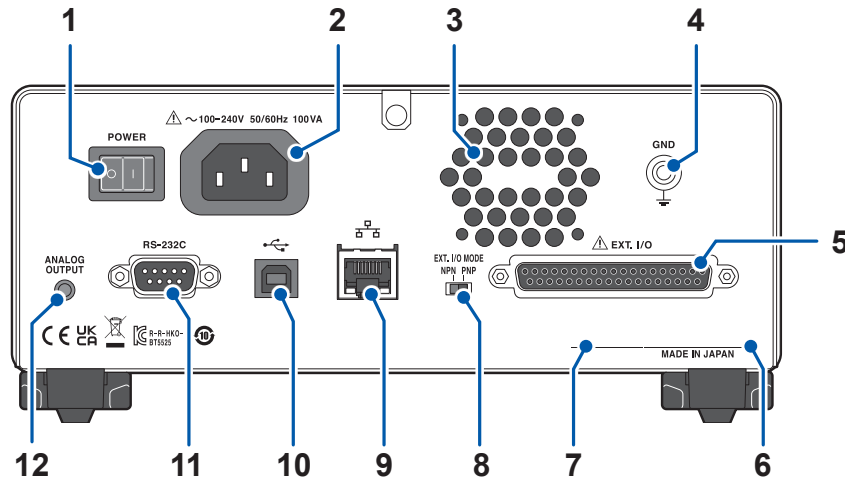

1	POWER switch	Switches the ON/OFF setting of the instrument power.	p.28
2	Power supply inlet	Connects the power cord provided with the instrument.	p.28
3	Vent	Ventilates the instrument to prevent the temperature of the inside from going up excessively.	p.14
4	GND terminal (functional ground terminal)	Connects the instrument to the ground.	–
5	EXT. I/O connector	Used to externally control the instrument.	p.83
6	Serial No.	The serial number consists of nine digits. The first two digits indicate the year of manufacture, while the second two digits indicate the month of manufacture. Do not remove this sticker as the number is important.	p.23
7	MAC address	MAC address of LAN. It is required for instrument control. Do not remove it.	–
8	EXT. I/O MODE switch (NPN/PNP)	Switches the type of PLC (programmable logic controller) to be connected to the EXT. I/O.	p.85
9	LAN connector	LAN (socket communications) enables the PC to control the instrument. Measurement data can be transferred to the PC.	p.103
10	USB connector	USB communications (virtual COM port) enables the PC to control the instrument. Measurement data can be transferred to the PC.	p.110
11	RS-232C connector	RS-232C communications (serial communications) enables the PC to control the instrument. Measurement data can be transferred to the PC.	p.101
12	ANALOG OUTPUT terminal	Outputs measured values in analog.	p.97

Left side

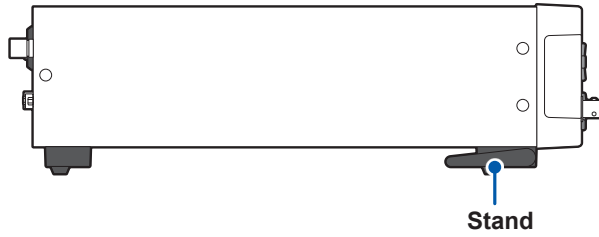

Bottom

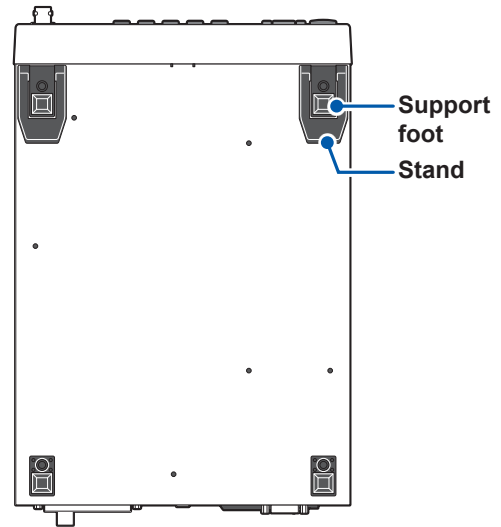

Right side

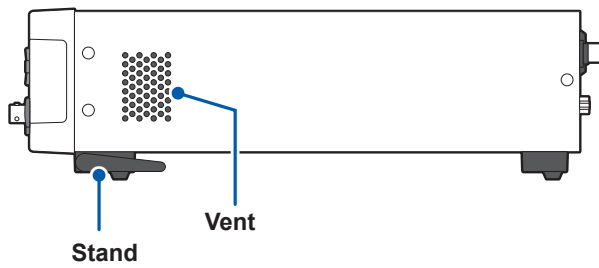

Stand

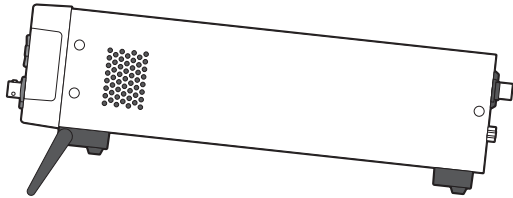

Using the instrument with the stands

Unfold the stands all the way.
Be sure to unfold both of the stands.

Closing the stands

Fold the stands all the way.

CAUTION



- Do not subject the instrument to excessive force from above when the stands are extended.

Doing so could damage the stands.

1.4 Screen Configuration and Operation Overview

This instrument incorporates a measurement screen and various setting screens. To enhance readability, the screens are displayed in the black and white inversion mode in this manual. The screen display cannot be inverted for this instrument.

1

Overview

Measurement screen

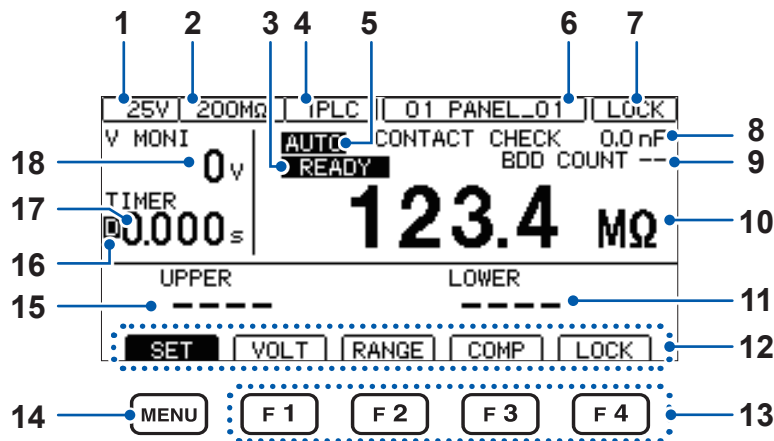

1	Test voltage	Displays the test voltage setting.
2	Resistance range	Displays the resistance range setting.
3	[READY] indication	Displayed if a test is ready to be started when the START key is pressed.
4	Sampling time	Displays the sampling time setting.
5	[AUTO] indication	Displayed when the auto range is selected. Nothing is displayed when the manual range is set.
6	Panel name	Displays the panel name.
7	Lock status display	[LOCK] Key lock [ILOCK] Interlock [RMT] Remote lock
8	Contact check result	Displays the contact check result.
9	BDD result	Displays the BDD result.
10	Measured value	Displays the measured value.
11	Comparator lower limit value	Displays the lower limit value specified using the comparator function.
12	F key function display	Displays user-selectable items using the F keys underneath the display.
13	F key	[VOLT] Sets the edit mode for the test voltage. (p.34) [RANGE] Sets the edit mode for the resistance range. (p.36) [COMP] Moves to the comparator setting screen. (p.44) [LOCK] Executes the key lock function. (p.68)
14	MENU key	Switches between the measurement screen and a setting screen.
15	Comparator upper limit value	Displays the upper limit value specified using the comparator function.
16	[D] indication	Displayed during comparator delay.
17	Timer time	Displays the test time. When the test time is set to OFF, the timer counts up. When it is set to ON, the timer counts down.
18	Voltage monitor value	Displays the voltage value between the measurement terminals being tested.

Setting screen

MEAS1 [MEAS1] screen

	MEAS1	MEAS2	PANEL	SYS	IF	INFO
Test voltage (p.34)	VOLTAGE			025 V		
Range (p.36)	RANGE			AUTO		
Sampling time (p.38)	SPEED			001 PLC		
Measurement delay time (p.39)	MEAS DELAY			001 PLC		
Test time (p.40)	TIMER			OFF		
Comparator delay time (p.40)	COMP DELAY			AUTO		
Test mode (p.46)	COMP MODE			CONTINUE		
Judgment result beep (p.47)	COMP BEEP			FAIL	TONE1	
	EXIT					

MEAS2 [MEAS2] screen

	MEAS1	MEAS2	PANEL	SYS	IF	INFO
Contact check (p.58)	CONTACT CHECK			OFF		
BDD threshold value (p.60)	BDD THRESHOLD		CC V	OFF		
			CV V	OFF		
			CV I	OFF		
BDD stop function (p.60)	BDD STOP			OFF		
BDD judgment (p.63)	BDD COMP			OFF		
Current limit (p.64)	CURRENT LIMIT			MANUAL	02.00 mA	
	EXIT					

PANEL [PANEL] screen

	MEAS1	MEAS2	PANEL	SYS	IF	INFO
	01	-----				
	02	-----				
Panel save, panel load (p.77)	03	-----				
	04	-----				
	05	-----				
	06	-----				
	07	-----				
	08	-----				
	EXIT					

SYS [SYS] screen

	MEAS1	MEAS2	PANEL	SYS	IF	INFO
Key operation sound (p.67)	KEY CLICK			ON		
Key lock function with a passcode (p.69)	KEY LOCK PASSCODE			OFF		
Screen contrast (p.72)	LCD CONTRAST			50		
Backlight (p.73)	LCD BACK LIGHT			2		
Power supply frequency (p.74)	POWER FREQUENCY			AUTO(60Hz)		
EXT. I/O test (p.95)	EXT I/O TEST			EXEC		
Initialization (p.75)	RESET			EXEC		
	EXIT					

IF screen

	MEAS1	MEAS2	PANEL	SYS	IF	INFO
RS-232C communications speed (p.101)	RS-232C SPEED			9600bps		
LAN IP address (p.106)	LAN IP ADDRESS			192.168.	1.	1
LAN subnet mask (p.106)	SUBNET MASK			255.255.	0.	0
LAN default gateway (p.106)	DEFAULT GATEWAY			0.	0.	0
LAN port number (p.106)	TCP PORT			00023		
Auto data output function (p.111)	AUTO DATA OUT			OFF		
Command monitor function (p.112)	CMD MONITOR			OFF		
	EXIT					

INFO screen

	MEAS1	MEAS2	PANEL	SYS	IF	INFO
Model number/Manufacturing serial number*	MODEL / NO.			BT5525 /	22	1012345
CPU version	CPU VERSION			V1.000		
FPGA version main/sub	FPGA VERSION			A2210123 /	B22	10123
LAN MAC address	MAC ADDRESS			00-00-00-00-00-00		
Calibration date	CALIB DATE			2022/10/01		
Adjustment date	ADJUST DATE			2022/10/01		
Adjusted by	ADJUST BY			HIOKI		
Error information (p.197)	ERROR INFO			0."No Error"		
	EXIT					

* The serial number consists of nine digits. The first two digits indicate the year of manufacture, while the second two digits indicate the month of manufacture.

1.5 Test Flow

Before using the instrument, be sure to read “Precautions for Use” (p.14) .

1 Inspect the instrument for any problems.

See “2.1 Inspecting the Instrument before Test” (p.26) .

2 Prepare for starting a test.

See “2 Test Preparation” (p.25).

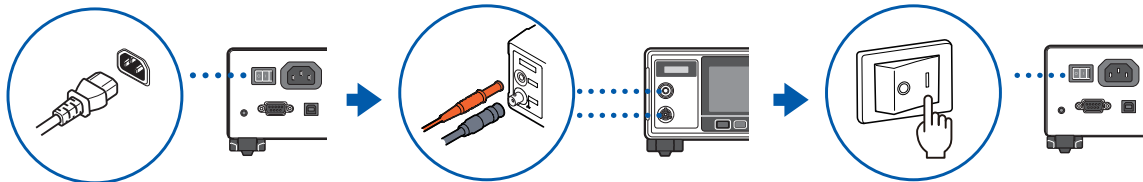

3 Set the measurement conditions.

See “3 Basic Settings” (p.33).

Item	Description	Reference
Test voltage	Sets the test voltage between 25 V and 500 V.	p.34
Resistance range	Sets the resistance range from manual (2 MΩ, 20 MΩ, 200 MΩ, 2000 MΩ) or auto.	p.36
Sampling time	Sets the sampling time between 1 PLC and 100 PLCs.	p.38
Test time	Sets the time during which the test voltage is applied (test time function).	p.40
	Sets the comparator delay time.	
Comparator (upper/lower limit values)	Sets the judgment upper/lower limit values.	p.44
Test mode	Selects the test mode from continuous, FAIL STOP, or PASS STOP.	p.46
Beep	Sets the conditions for announcing a judgment result using a beep.	p.47

4 Start the test.

See “4.1 Starting a Test” (p.49)

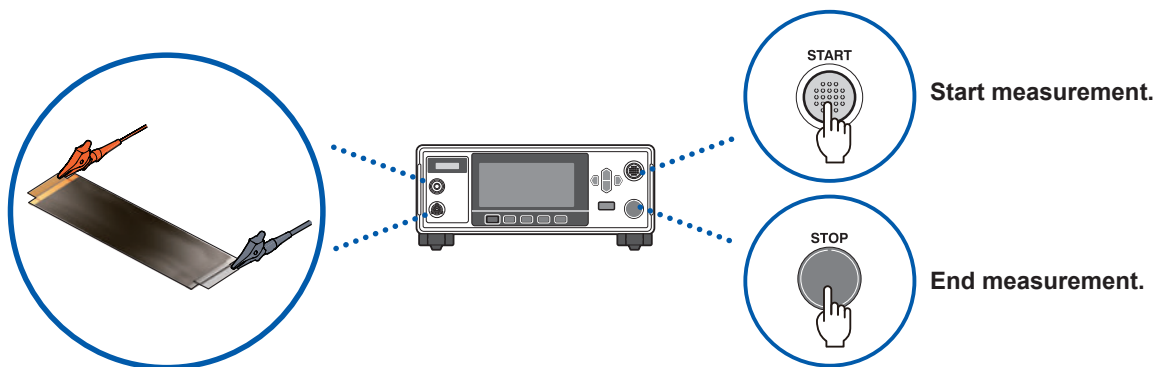

5 End the test.

See “4.5 Ending the Test” (p.55)

6 Turn off the power after using the instrument.

2

Test Preparation

This chapter explains preparation prior to starting a test.

1	Inspecting the instrument before test	p.26
	▼	
2	Connecting a power cord	p.28
	▼	
3	Connecting the test leads to the instrument	p.30
	▼	
4	Supplying power to the instrument	p.29
	▼	
5	Connecting a communications cable to the instrument	p.30
	▼	
6	Connecting the test leads to the DUT	p.31
	▼	
7	Shutting down the output of the instrument (interlock function)	p.32

2

2.1 Inspecting the Instrument before Test

DANGER

- Before use, verify that test lead insulation is not torn and that no metal is exposed.



- Before use, inspect the instrument and verify that it's operating properly.

Using test leads or an instrument that is damaged could result in serious bodily injury. If you discover any damage, replace with a Hioki-specified part.

Inspecting accessories and options

Check item	Action
The coating of the power cord is not ripped. No metal parts of the power cord are exposed.	If there is any damage Do not use the power cord as the damaged cord can cause electric shock or short circuit accidents. Please contact your authorized Hioki distributor or reseller.
The coating of the test leads is not ripped. No metal parts of the test leads are exposed.	If there is any damage Replace with those specified by our company as the damaged test leads can cause electric shock accidents.
The resistance value is normal after checking the insulation resistance test.	If the resistance value is not normal There may be a short circuit between the conductors inside the test lead. Replace with those specified by our company as the damaged test leads can cause false judgment.

Inspecting the instrument

Check item	Action
The instrument is not damaged.	If there is any damage Request repair.

Checking the insulation resistance test

Perform the following inspection before starting a test to use this instrument safely.

Check item	Action
The measured resistance value matches the resistance value of the prepared resistor.	See "Checking the insulation resistance test" (p.27).

Checking the insulation resistance test

Tools to be prepared

Recommended resistor High voltage/high resistance thick film resistor GS series

Manufacturer KOA Corporation or an equivalent resistor

Pay attention to the voltage and wattage to be used.

CAUTION



- Do not input any test voltage (wattage) exceeding the rated voltage (wattage) of the prepared resistor.

The resistor can be damaged.

2

Test Preparation

Setting example

When the insulation resistance value of the DUT is 100 MΩ and the test voltage to be applied is 500 V

- 1 Prepare a resistor suitable for the insulation resistance value of the DUT.
- 2 Make sure that the test voltage is lower than the maximum service voltage of the prepared resistor.

Test voltage < Maximum service voltage of the prepared resistor

Check that the power consumption calculated from the test voltage and insulation resistance value of the DUT is less than the rated power of the prepared resistor.

(If the power consumption calculated from the test voltage and insulation resistance value of the DUT is greater than the rated power of the prepared resistor, change either the resistor or the test voltage.)

Example

Square of the test voltage / Insulation resistance value of the DUT < Rated power of the prepared resistor

$$\frac{500 \text{ V} \times 500 \text{ V}}{100 \text{ M}\Omega} = 0.0025 \text{ W} < 0.5 \text{ W}$$

- 3 Set the test voltage to 500 V.
- 4 Set the lower limit value to 90 MΩ and the upper limit value to 110 MΩ (when a 100 MΩ resistor is used).
- 5 Connects the test leads to the prepared resistor.
- 6 Start the test.
- 7 Check that the measured resistance value matches the resistance of the prepared resistor and the comparator judgment result is **[PASS]**.

2.2 Supplying Power to the Instrument

Connecting the power cord

⚠ CAUTION



- Do not use a power supply that generates rectangular wave or pseudo-sine wave output (an uninterruptible power supply, DC/AC inverter, etc.) to power the instrument.

Doing so could damage the product or result in bodily injury.

- Do not connect the power supply incorrectly.

Doing so could damage the product or result in bodily injury.



- Before connecting the power cord to the instrument, verify that the supply voltage you plan to use falls within the supply voltage range noted on the instrument's AC inlet.

Supplying a voltage that falls outside the specified voltage range to the instrument could damage the instrument, causing bodily injury.

- Unplug the power cord from the instrument when the instrument is not used.

Failure to do so could cause the operator to experience an electric shock.

- When unplugging the power cord from the outlet or instrument, pull on the plug (not the cord).

Failure to do so could cause a wire break in the power cord.

- 1 Make sure that the instrument power switch is set to OFF.
- 2 Check that the power voltage to be used is within the rated power voltage and then connect the power cord to the power supply inlet.
- 3 Connect the plug of the power cord to the outlet.

The instrument's power supply frequency must be switched in order to reject noise caused by that frequency. Set the power frequency being used before making any measurements. Measured values will not stabilize if the power supply frequency has not been set properly.

See "5.8 Manually Setting the Frequency of the Power Supply" (p.74)

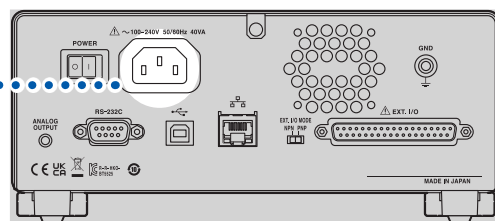
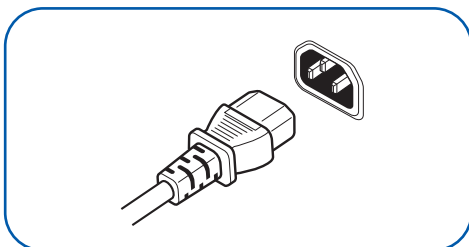

Turning the instrument on and off

⚠ WARNING

- 
Connect the instrument's power cord to a grounded, two-prong power outlet.
 Connecting the instrument to an ungrounded power outlet could cause the operator to experience an electric shock.

⚠ CAUTION

- 
When unplugging the power cord from the outlet or instrument, pull on the plug (not the cord).
 Failure to do so could cause a wire break in the power cord.

The power switch is located at the back of the instrument.

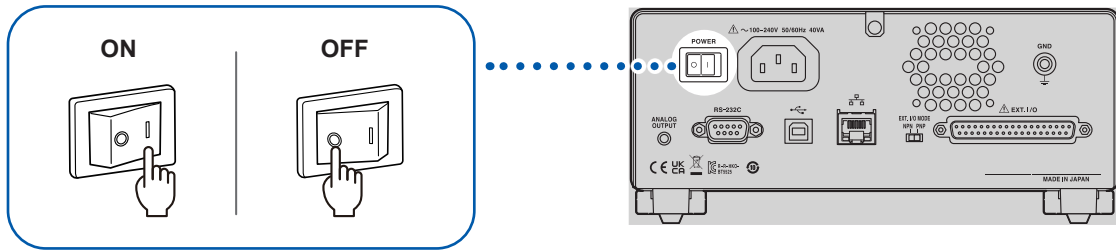

2.3 Connecting the Test Leads

Connect the optional test leads to the measurement terminals.
See "Options" (p.9)

⚠ WARNING

- **Disconnect power to the circuit to which the DUT is connected before connecting the test leads to the terminals.**



Failure to do so could damage the instrument or result in bodily injury.

- **When using this instrument, use only Hioki specified test leads.**

Using a test lead other than the specified parts could result in bodily injury or a short-circuit.

⚠ CAUTION



- **When disconnecting the test lead of the LOW terminal, disengage the lock and then pull out the BNC connector while gripping it at the connection (do not pull on the cable).**

Failure to observe this instruction may damage the BNC connector or joints.

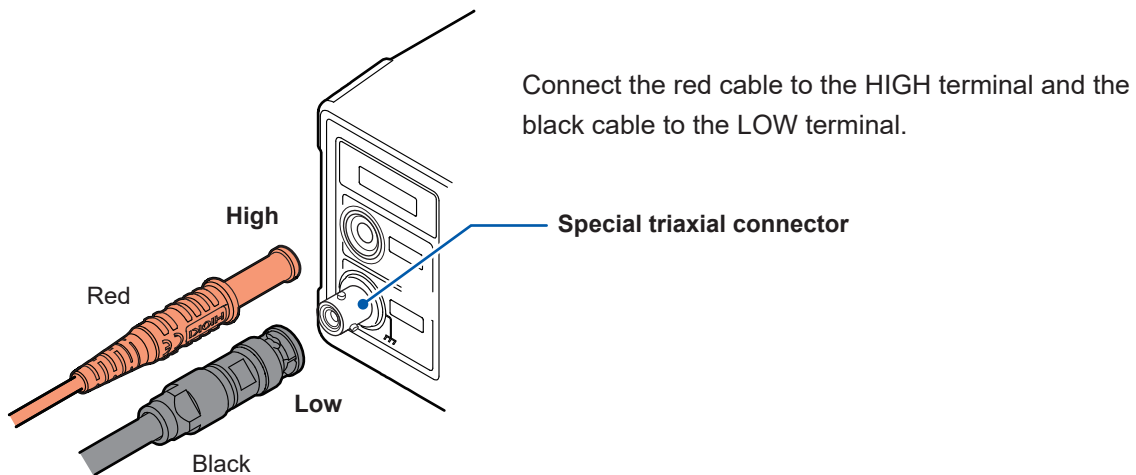

2.4 Connecting a Communications Cable

The instrument can be controlled using the RS-232C interface, LAN interface, or USB interface. Connect the appropriate communications cable to the RS-232C connector to use the RS-232C interface, to the LAN connector to use the LAN interface, and to the USB connector to use the USB interface.

See "8.2 RS-232C Interface" (p. 101), "8.3 LAN Interface" (p. 103), and "8.4 USB Interface" (p. 110).

2.5 Connecting the Test Leads to the Device Under Test (DUT)

⚠ DANGER



- **Do not short wires carrying a voltage with the tips of the test leads.**

Doing so could cause a short-circuit, resulting in serious bodily injury.

⚠ CAUTION



- **Adequately discharge the residual electric charge of the DUT before connecting the test leads.**

Connecting the test leads to the charged DUT can damage the instrument.

1 Check the residual electric charge of the DUT.

Fully discharge any residual electric charge, if any, and then connect the test leads to the DUT.

2 Connect the test leads to the DUT.

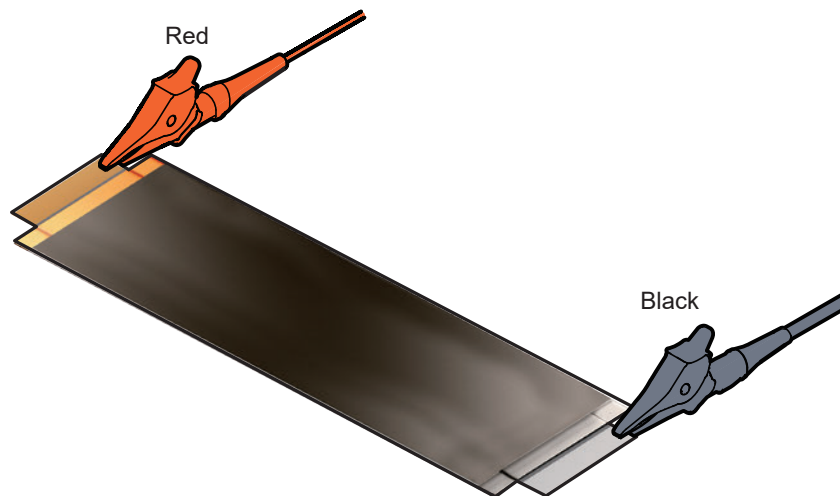

3 Start the test.

See “4.1 Starting a Test” (p.49).

In order to perform a test safely, inspect the instrument prior to the test.

See “2.1 Inspecting the Instrument before Test” (p.26).

2.6 Shutting Down the Output of the Instrument (Interlock Function)

The interlock function is a function to shut down the output of the instrument by linking with external equipment, etc.

When the interlock operates, **START** key operation is disabled. Due to this, any test cannot be started even with the EXT. I/O START signal or a communications command.

When EXT. I/O pin No. 3 (INTERLOCK) is OFF (open), the interlock function is activated and the output of the instrument is shut down.

To start a test, set the pin to ON (short circuit).

You can still check the measured value and set the measurement conditions even in the interlock state.

If the **START** key is pressed during in the interlock state

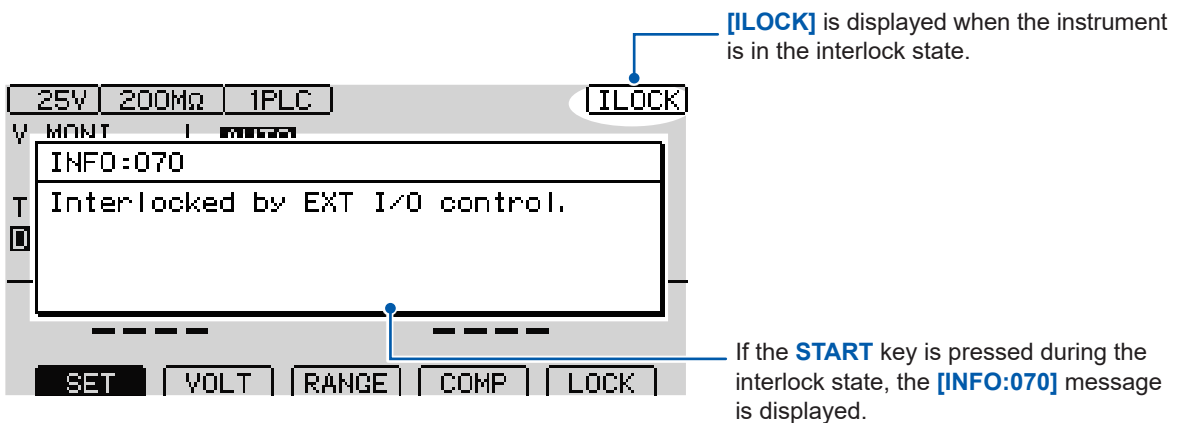

If the interlock activates during testing

If the interlock activates during testing, the output voltage will be halted, and the instrument will enter the stopped state.

In addition, the [INFO:104 Measurement aborted by interlock.] message will be displayed.

When using the EXT. I/O interlock cancellation jig

The included EXT. I/O interlock cancellation jig shorts the No. 3 (INTERLOCK) and No. 9 (ISO_COM) pins.

The interlock state can be cancelled by connecting the jig to the instrument's EXT. I/O connector.

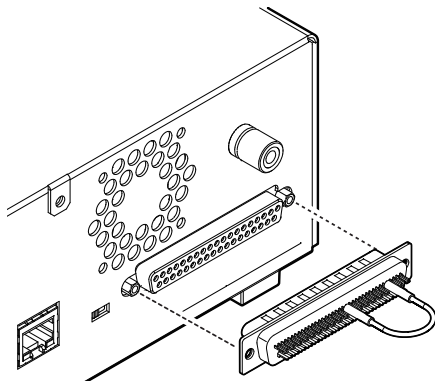

3

Basic Settings

This chapter explains the basic settings for using this instrument.

1	Setting the test voltage	p. 34
▼		
2	Setting the range (auto/manual)	p. 36
▼		
3	Switching the sampling time	p. 38
▼		
4	Limiting the current to be applied to the DUT	p. 64
▼		
5	Setting the measurement delay time	p. 39
▼		
6	Setting the test time and comparator delay time	p. 40
▼		
7	Judging the measured value (comparator function)	p. 44
▼		
8	Setting the test mode	p. 46
▼		
9	Notifying the judgment result and test completion with a beep	p. 47
▼		
10	Checking for any contact defects and confirming contact condition (contact check function)	p. 58
▼		
11	Detecting micro insulation failure (BDD function)	p. 60

3.1 Setting the Test Voltage

Set the test voltage in the range between 25 V and 500 V.

As the measurement range is determined based on the test voltage, any measurement range not suitable for the setting is automatically changed. The test voltage can be set in the Measurement screen or Setting screen. When the test voltage is set, the instrument will stop accepting operations for about 1 second to allow the internal circuit's voltage to stabilize. Please wait for the setting to complete.

⚠ CAUTION



■ **Set the test voltage correctly.**

An inappropriate test voltage can damage the DUT.

Setting the test voltage in the Measurement screen

1 Set the test voltage to the edit mode.

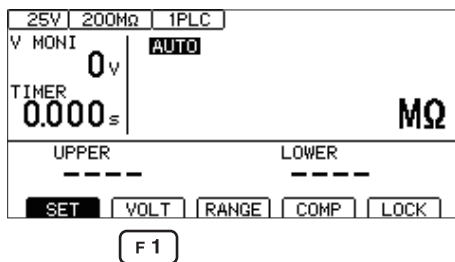

F 1 [VOLT] Select

2 Change and confirm the test voltage value.

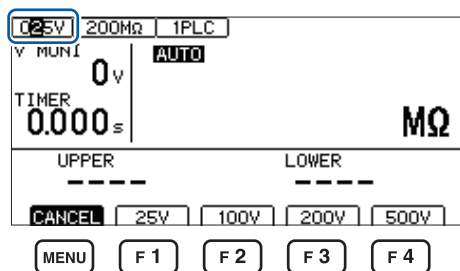

- Change the value (up/down).
- Change the cursor position (left/right).

Select the preset voltage.

F 1 [25V]

F 2 [100V]

F 3 [200V]

F 4 [500V]

ENTER Confirm

MENU [CANCEL] Cancel

Setting the test voltage in the Setting screen

1 Open the Setting screen.

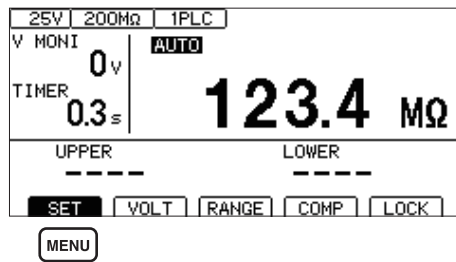

MENU [SET] Select

2 Set [VOLTAGE] to the edit mode.

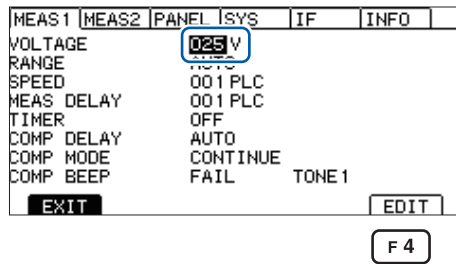

Select

F 4 [EDIT] Edit

3 Change and confirm the test voltage value.

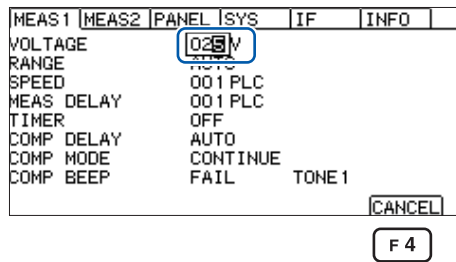

• Change the value (up/down keys)
• Change the cursor position (left/right keys)

ENTER Confirm

F 4 [CANCEL] Cancel

3.2 Setting the Range (Auto/Manual)

There are two range settings, auto range and manual range. For the manual range, you can select from four settings, 2 MΩ, 20 MΩ, 200 MΩ, and 2000 MΩ. The range that can be set, however, varies depending on the test voltage.

See “9.2 Input, Output, and Measurement Specifications” (p. 180).

In the auto range, range movement takes place after the test starts. It may take time for the measured value to be displayed. In order to eliminate the wait time, set the range to manual according to the DUT.

Setting the test voltage in the Measurement screen

1 Set the range to the edit mode.

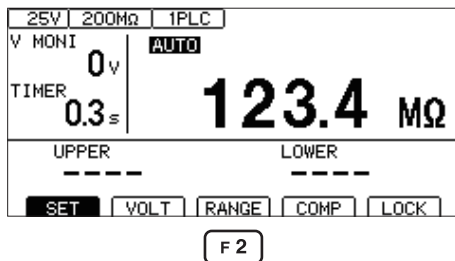

F 2 [RANGE] Select

2 Change and confirm the range.

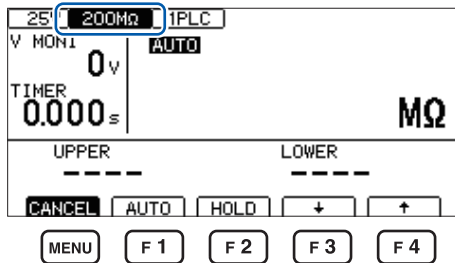

 Select the range

F 1 [AUTO] Set the auto range

F 2 [HOLD] Set the manual range

F 3 [↓] Lower the range

F 4 [↑] Raise the range

ENTER Confirm

MENU [CANCEL] Cancel

Setting the test voltage in the Setting screen

1 Open the Setting screen.

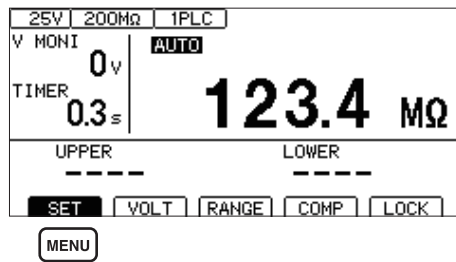

MENU [SET] Select

2 Set [RANGE] to [AUTO] or [HOLD].

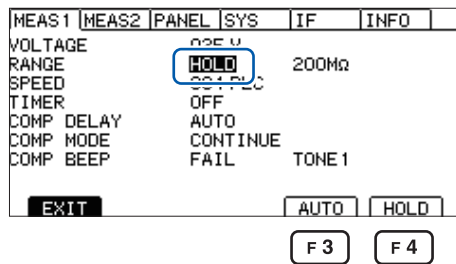

Select

F3 [AUTO] Set the auto range

F4 [HOLD] Set the manual range

3 Select the range when the manual range is selected.

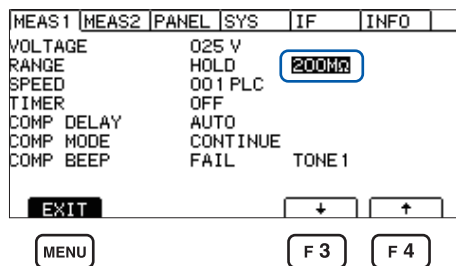

Select

F3 [↓] Lower the range

F4 [↑] Raise the range

MENU [EXIT] Return to the Measurement screen

IMPORTANT

It may take time for measured values to stabilize in the following circumstances:

- When using the 200 MΩ range with a set voltage of 25 V to 99 V
- When using the 2000 MΩ range with a set voltage of 100 V to 500 V

When the auto range is selected, [AUTO] is displayed in the Measurement screen.

See “Measurement screen” (p. 21).

When analog output is used, 0 V to 4 V is output from the analog output terminal according to each resistance range.

See “7.6 Using Analog Output” (p. 97).

3.3 Setting the Sampling Time

Set the sampling time in the range between 1 PLC and 100 PLCs.
 1 PLC is equivalent to one cycle of a power supply frequency.

50 Hz	1 PLC = $1/50 = 20$ ms
60 Hz	1 PLC = $1/60 = 16.7$ ms

When the measured value is difficult to read due to a fluctuation, increase the sample time value.

1 Open the Setting screen.

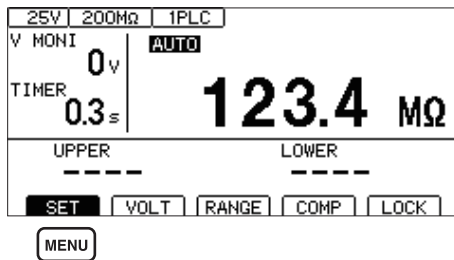

MENU [SET] Select

2 Set the sampling time.

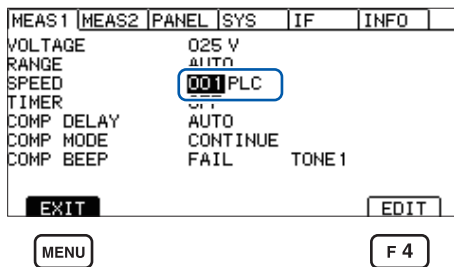

Select

F 4 [EDIT] Edit

• Change the value (up/down keys)
 • Change the cursor position (left/right keys)

ENTER Confirm

MENU [EXIT] Return to the Measurement screen

IMPORTANT

If the test time is shorter than the sampling time, the measured value is not displayed. Set a longer test time than the sampling time.

3.4 Setting the Measurement Delay Time

Set the delay time that is allowed to elapse from the start of the test to the start of insulation resistance measurement.

By setting a measurement delay time equal to interval during which measured values exhibit instability immediately after the test voltage is applied, you can realize stable insulation resistance measurement.

Set the measurement delay time in the range between 1 PLC and 100 PLCs. 1 PLC is equivalent to one cycle of a power supply frequency.

50 Hz	1 PLC = 1/50 = 20 ms
60 Hz	1 PLC = 1/60 = 16.7 ms

3

1 Open the Setting screen.

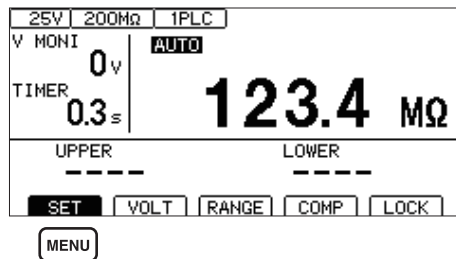

MENU [SET] Select

2 Set the measurement delay time.

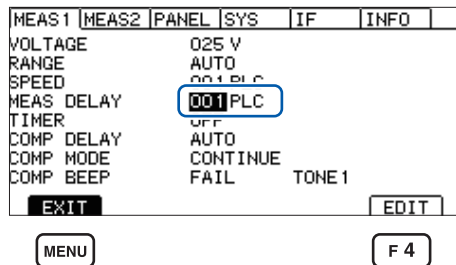

Select

F 4 [EDIT] Edit

- Change the value (up/down keys)
- Change the cursor position (left/right keys)

ENTER Confirm

MENU [EXIT] Return to the Measurement screen

3.5 Setting the Test Time and Comparator Delay Time

Setting the time during which a test voltage is applied

The test time is the time period during which a test voltage is applied.

IMPORTANT

- As the range movement takes time in the auto range, a test is ended without displaying the measured value if a short test time is set. When the auto range is selected, check the time until the measured value is stabilized and set the test time.
- Depending on the DUT, the measured resistance value may drop as time passes. (For instance, when the ground to ground capacitance is high)
When an improper test time is set, false judgment may occur. Properly check the time until the measured value is stabilized and set the test time.
- The measured value may not be stabilized due to environmental influences, such as humidity. Check the time until the measured value is stabilized and set the test time.

1 Open the Setting screen.

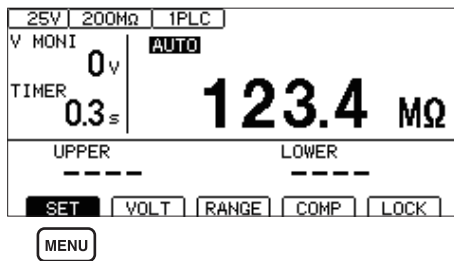

MENU [SET] Select

2 Set [TIMER] to [ON].

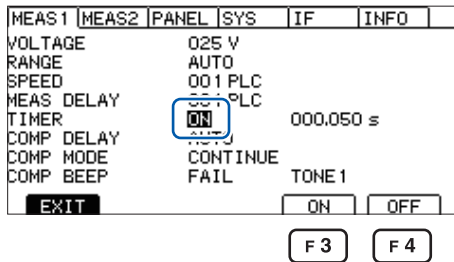

Select (up/down keys)

F 3 [ON]

F 4 [OFF]

3 Switch to the edit mode.

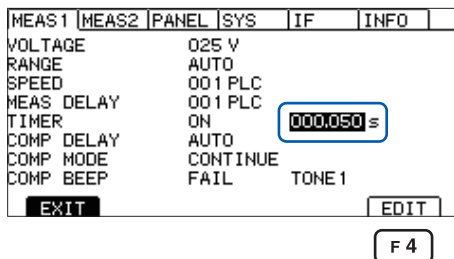

Select (left/right keys)

F 4 [EDIT] Edit

4 Set the test time.

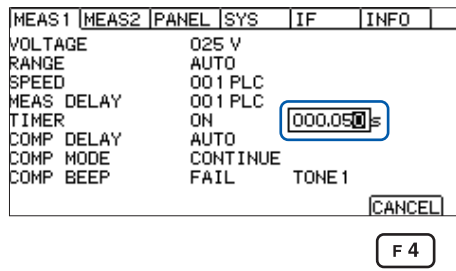

- Change the value (up/down keys)
 - Change the cursor position (left/right keys)
- ENTER Confirm
- F 4 [CANCEL] Cancel

Setting the comparator delay time

The comparator delay time is a time duration used to disable comparator judgment after the test starts until the set time elapses. When the comparator delay time is set, comparator judgment can be performed after the DUT has been charged.

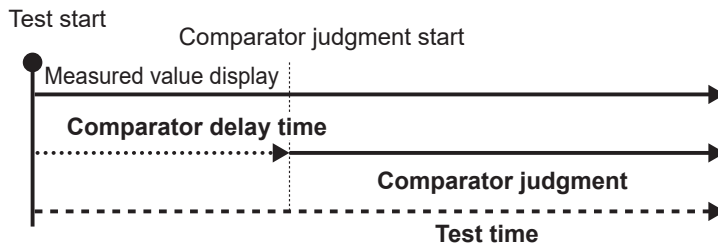

IMPORTANT

- The charging time varies depending on the DUT. For a capacitive load, it may take a long time for the output voltage to rise.
- When the comparator delay time is set to **[AUTO]**, comparator judgment starts after the voltage monitor value is monitored and the voltage is stabilized. The time until the voltage is stabilized varies depending on the DUT.
- When the response time is set to **[MANUAL]**, judgment starts after a specified time. Comparator judgment may start before the voltage is stabilized for some DUTs. Set the comparator delay time based on the DUT.

[D] is displayed at the left side of the test time in the Measurement screen during comparator delay.

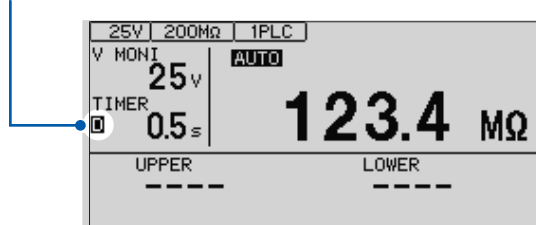

Setting the comparator delay time to manual

1 Open the Setting screen.

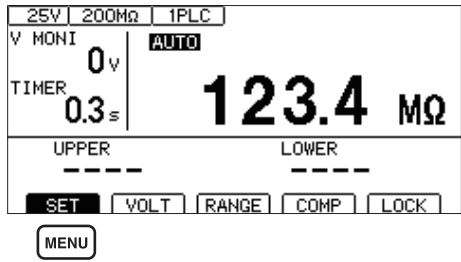

MENU [SET] Select

2 Set [COMP DELAY] to [MANUAL].

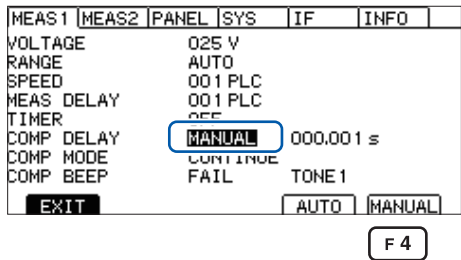

Select

F 4 [MANUAL]

3 Switch to the edit mode.

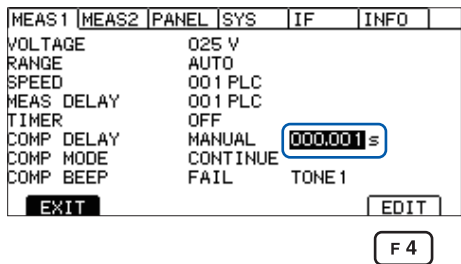

Select

F 4 [EDIT] Edit

4 Set the comparator delay time.

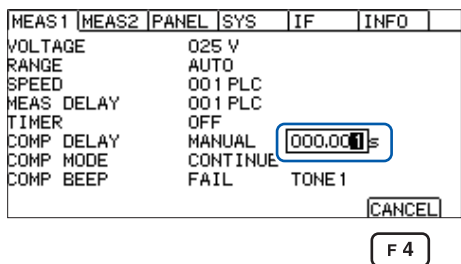

• Change the value (up/down keys)
 • Change the cursor position (left/right keys)

ENTER Confirm

F 4 [CANCEL] Cancel

Setting the comparator delay time to auto

1 Open the Setting screen.

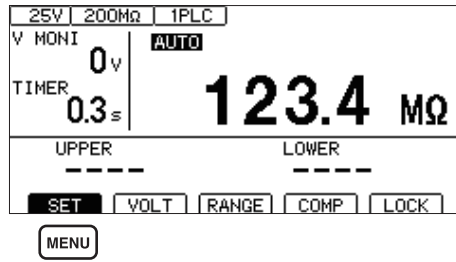

MENU [SET] Select

2 Set [COMP DELAY] to [AUTO].

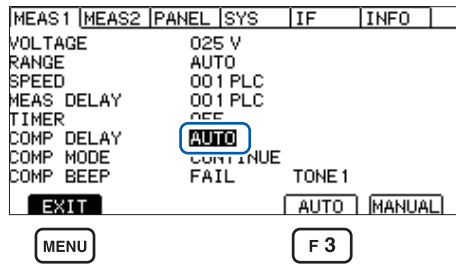

Select

F 3 [AUTO]

MENU [EXIT] Return to the Measurement screen

3

Basic Settings

3.6 Judging the Measured Value (Comparator Function)

By using the comparator function, the following can be performed.

Displaying the judgment result on the instrument (COMP lamp U. FAIL / PASS / L. FAIL)

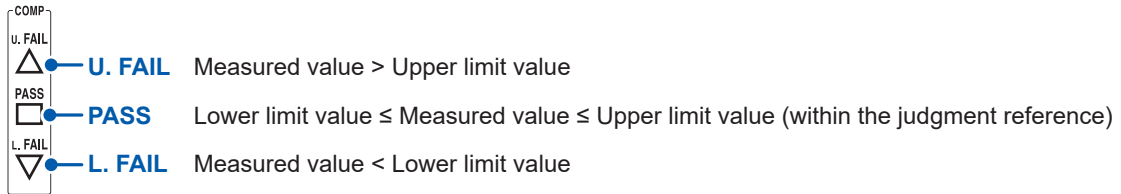

Sounding a buzzer (Default: FAIL)

See “3.8 Notifying the Judgment Result and Test Completion with a Beep” (p. 47).

Externally outputting the judgment result

See “7 External Control (EXT. I/O)” (p. 83).

There are the following three judgment methods. The setting range of the upper/lower limit values is from 0.000 MΩ to 9999 MΩ.

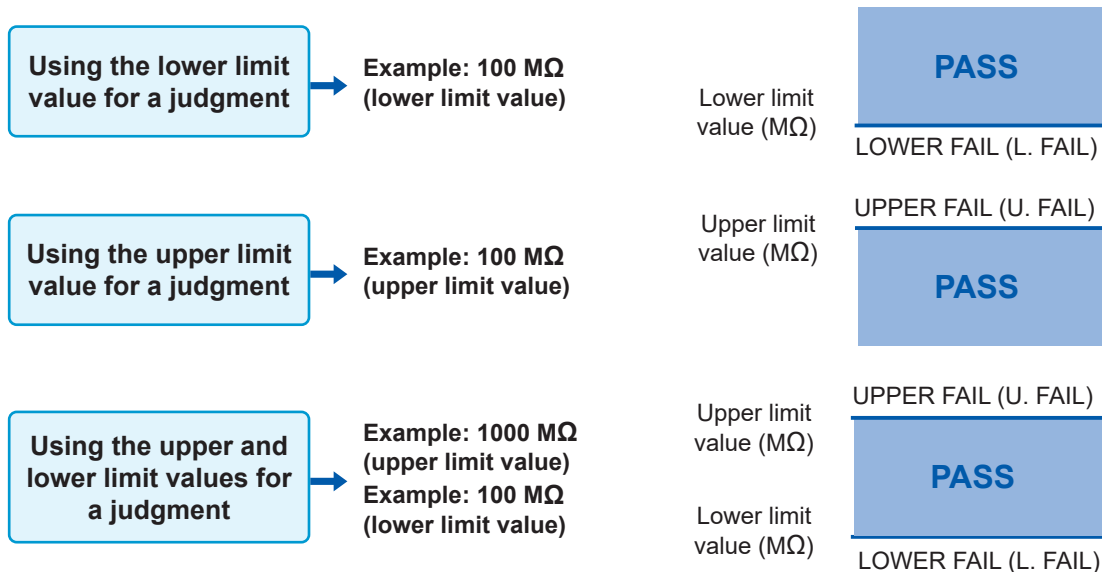

IMPORTANT

In the following circumstances, **[U. FAIL]** and **[L. FAIL]** light up simultaneously (UL.FAIL):

- When no judgment is possible because the measured value is **[Over.F]** (overflow) due to the upper or lower limit value being greater than the display range’s upper limit.
- When no judgment is possible because the measured value is **[Under.F]** (underflow) due to the upper or lower limit value being less than the display range’s lower limit.
- When the BDD count is 1 or greater while the comparator function and BDD judgment are enabled.

See “Enabling BDD judgment” (p. 63).

1 Select [COMP].

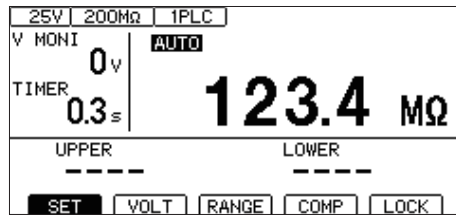

F 3 [COMP] Select

F 3

2 Turn ON the comparator function.

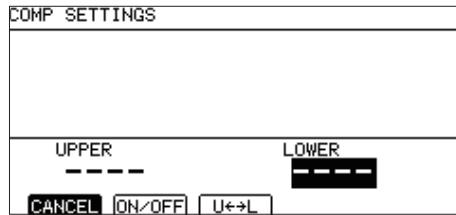

F 1 [ON/OFF] Select

F 2 [U← →L] Switch the upper/lower limit
The comparator function can be set to ON/OFF for each upper limit value and lower limit value.

MENU [CANCEL] Cancel

F 1 F 2

When the comparator function is ON, a value is displayed. When it is OFF, [----] is displayed.

When the comparator function is ON



When the comparator function is OFF



3 Set and confirm the value.

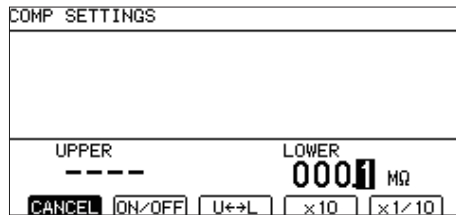

◀ ▶ • Change the value (up/down keys)
◀ ▶ • Change the cursor position (left/right keys)

F 3 [×10] Move the decimal point to the right

F 4 [×1/10] Move the decimal point to the left

F 3 F 4

ENTER Confirm

3.7 Setting the Test Mode

The following test modes are available.

[CONT]	Continuous test mode Outputs the judgment result for each sampling and performs a test until the set test time elapses.
[PASS]	PASS STOP mode Outputs the judgment result for each sampling and ends the test when a PASS judgment is determined.
[FAIL]	FAIL STOP mode Outputs the judgment result for each sampling and ends the test when a FAIL judgment is determined.

1 Open the Setting screen.

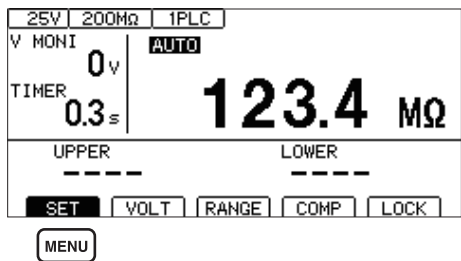

MENU [SET] Select

2 Set the test mode.

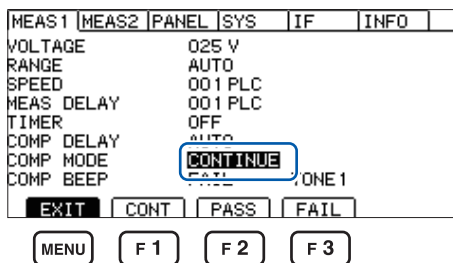

Select

F 1 [CONT]

F 2 [PASS]

F 3 [FAIL]

MENU [EXIT] Return to the Measurement screen

3.8 Notifying the Judgment Result and Test Completion with a Beep

The following are the conditions for notifying the judgment result and test completion with a beep. You can choose from three tones.

[OFF]	No beep
[PASS]	Issues a beep when the judgment result is PASS.
[FAIL]	Issues a beep when the judgment result is FAIL.
[END]	Issues a beep when the test is completed, regardless of the judgment result.

1 Open the Setting screen.

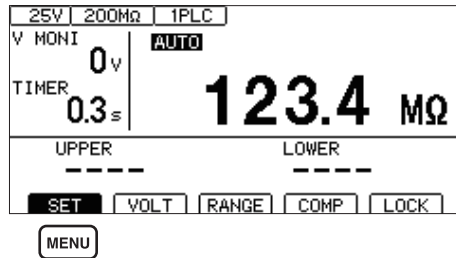

[MENU] [SET] Select

2 Set the conditions for the beep.

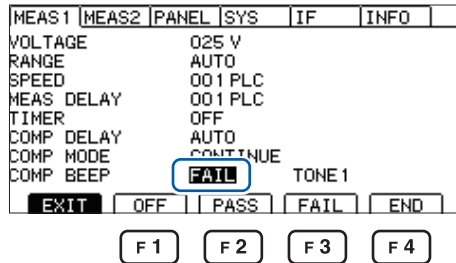

Select

[F1] [OFF]
 [F2] [PASS]
 [F3] [FAIL]
 [F4] [END]

3 Change the tone of the beep.

Press the **F2**, **F3**, or **F4** key to set the beep and check its volume.

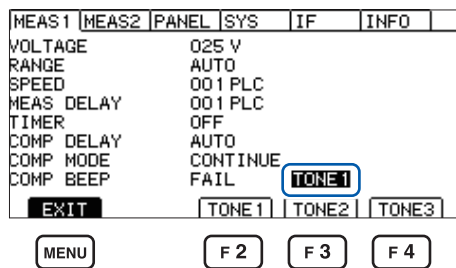

Select

[F2] [TONE1] High
 [F3] [TONE2] Medium
 [F4] [TONE3] Low
 [MENU] [EXIT] Return to the Measurement screen

4 Test Method

This chapter explains the test method using this instrument.

4.1 Starting a Test

The two-stage operation using the **STOP** key and **START** key avoids unnecessary output and allows a test to start safely.

⚠ WARNING

- **Do not measure insulation resistance while the circuit is energized.**

Doing so could damage the instrument or result in bodily injury.
Turn off power to the DUT before measurement.



- **Do not touch the DUT, tip of the test leads, and measurement terminals during and immediately after the test (while the TEST indicator is lighting).**

Since these areas are charged with high-voltage electric charge, electric shock accidents may occur.



- **Discharge the DUT using the discharge function of the instrument after the test.**

Otherwise, electric shock accidents may occur.

See “4.6 Discharging Residual Electric Charge (Auto Discharge Function)” (p. 56).

- 1 Set the measurement items.**

See “3 Basic Settings” (p. 33).

- 2 Disable the interlock.**

See “2.6 Shutting Down the Output of the Instrument (Interlock Function)” (p. 32).

- 3 Press the **STOP** key.**

[READY] is displayed for approximately 1 second on the Measurement screen.

TEST indicator lit (during test)

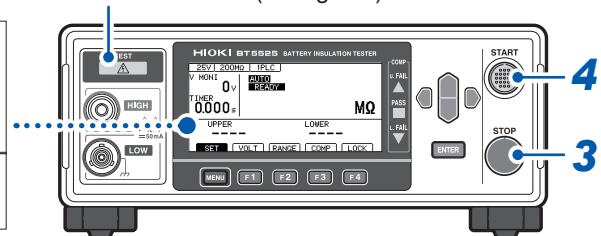
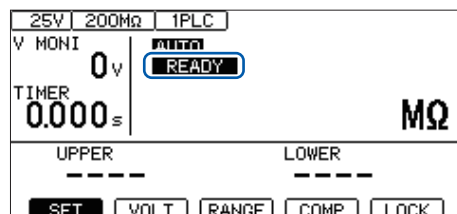

- 4 Press the **START** key while **[READY]** is displayed on the Measurement screen.**
The test starts.

IMPORTANT

- When you press the **START** key without pressing the **STOP** key, a beep sounds and **[INFO:102]** is displayed.



- In addition to the key operations, the EXT. I/O and communications command can be used to start and end the test. The test can be ended using a method different from the method used to start the test.
- The test cannot be started with the **STOP** key pressed.
- Check that the test leads are properly connected before starting the test.
- The test cannot be started with the EXT.I/O stop signal ON.
- The test cannot be started with the interlock activated. (p. 32)

4.2 Display during a Test

The test voltage is applied to the DUT from the instrument during the test.

If the test time is set to **[ON]**

See “3.5 Setting the Test Time and Comparator Delay Time” (p. 40).

When the **START** key is pressed, the test voltage is applied to the DUT and the timer starts counting down.

The remaining time is displayed in the test time display area (TIMER).

[D] is displayed at the left side of the countdown time during comparator delay.

The display during comparator delay is the same whether the comparator delay time is set to **[AUTO]** or **[MANUAL]**.

Resistance measurement is performed until the set timer time and then the measured value is displayed. (The unit is MΩ.)

When the comparator function is selected, a judgment is made according to the test mode setting. (p. 44)

If the test time is set to **[OFF]**

See “3.5 Setting the Test Time and Comparator Delay Time” (p. 40).

When the **START** key is pressed, the test voltage is applied to the DUT and the timer starts counting up.

The elapsed time after the **START** key was pressed is displayed in the test time display area (TIMER).

[D] is displayed at the left side of the countup time during comparator delay.

The display during comparator delay is the same whether the comparator delay time is set to **[AUTO]** or **[MANUAL]**.

Resistance measurement is performed until **STOP** is pressed and the measured value is displayed. (The unit is MΩ.)

The elapsed time display is stopped when the timer counts up to 999.9 s, however, the resistance measurement is performed until the **STOP** key is pressed.

When the comparator function is selected, a judgment is made according to the test mode setting. (p. 44)

4.3 Displaying the Measured Value

When the display range is exceeded, **[Over.F]** or **[Under.F]** is displayed on the screen.

The display range varies depending on the resistance range.

For the display range, see “9.2 Input, Output, and Measurement Specifications” (p. 180).

IMPORTANT

- In the auto range, it may take time for the measured value to be displayed due to range movement. Select the manual range to check the measured value immediately. See “3.2 Setting the Range (Auto/Manual)” (p. 36).
- If a test with the auto-range function enabled ends without the ranging having been determined at any point during the test, no measured value is shown. Set a longer test time.
- In the auto range, the range may swing between two ranges depending on the measured value. If this is the case, select the manual range.
- **[Over.F]** (overflow) is displayed when the display range of the maximum range is exceeded in the auto range and when the maximum display range of each range is exceeded in the manual range.
- The measured value tends to fluctuate more when the electrostatic capacitance included in the DUT is greater. Also it takes longer for the output voltage to rise.
- If the rise time of the voltage is short, the display update for voltage monitoring may not be able to keep up. When checking the output voltage, use a high voltage test lead and check the waveform on an oscilloscope, etc. However, the linearity of the output voltage’s rising edge may be compromised due to the effects of the input impedance of the high-voltage test leads or other waveform observation probes.

4.4 Memory Function

This instrument saves up to 999 measured values from the start to the end of the test in the internal memory. After the 1000th value, measured values will no longer be saved. The following information is saved:

Item	Description
Time stamp (ms)	Indicates the time from the start of high-voltage application until the resistance value is finalized. Does not include the contact check time.
Measurement status	Indicates the measured value status. For more information, see the description of the <code>:MEASure?</code> (p. 137) command.
Resistance value (Ω)	Indicates the insulation resistance value. For more information about the measured value format, see the description of the <code>:MEASure?</code> command.
Judgment result	Indicates the comparator judgment result. For more information, see the description of the <code>:MEASure?</code> command.
Voltage value (V)	Indicates the voltage value used to calculate the resistance value.
Current value (A)	Indicates the current value used to calculate the resistance value.
BDD result	Indicates the count detected by the BDD function.
Contact check result	Indicates the result of the contact check performed at the start of the test.

You can check the number of data points saved in memory using the `:MEASure:COUNT?` query (p. 139).

The measured values saved in the memory can be loaded using the `:MEASure:MEMory?` query (p. 139).

You can set which information to load with the command `:MEASure:VALid` command (p. 136).

The memory is cleared when the power is turned ON again or the test starts.

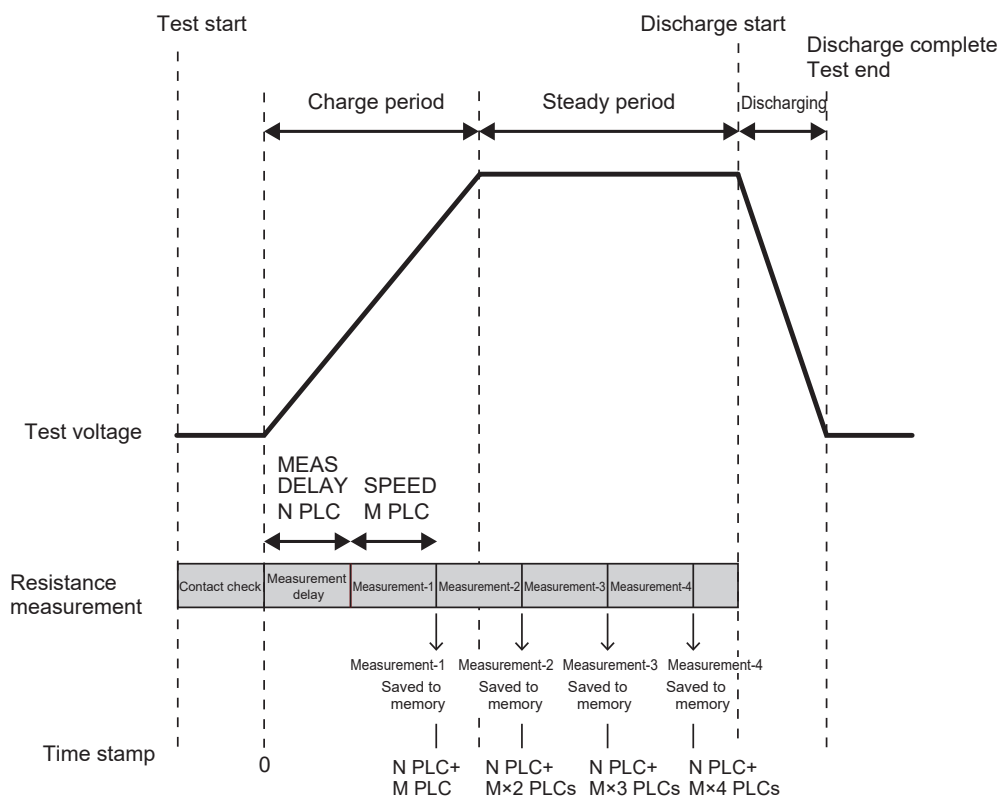

Setting example

Sampling time (SPEED)	1 PLC
Measurement delay (MEAS DELAY)	1 PLC
Test time (TIMER)	ON (0.250 s)
Comparator delay time (COMP DELAY)	MANUAL (0.100 s)
Contact check (CONTACT CHECK)	ON
BDD	OFF
Power supply frequency	AUTO (60 Hz)

Example of how communications commands can be used to acquire values saved in memory

```

:MEASure:VALid 255
:MEASure:COUNT?
14
:MEASure:MEMory? CRLF
 33, 0, 7.20E+06,NOCOMP,1.44008E+01,2.00006E-06, 0,PASS
 50, 0,11.08E+06,NOCOMP,2.41241E+01,2.17791E-06, 0,PASS
 67, 0,11.50E+06,NOCOMP,2.50000E+01,2.17485E-06, 0,PASS
 83, 0,11.66E+06,NOCOMP,2.50002E+01,2.14450E-06, 0,PASS
100, 0,11.85E+06, PASS,2.50003E+01,2.11008E-06, 0,PASS
117, 0,12.04E+06, PASS,2.50005E+01,2.07578E-06, 0,PASS
133, 0,12.24E+06, PASS,2.50004E+01,2.04193E-06, 0,PASS
150, 0,12.44E+06, PASS,2.49999E+01,2.00895E-06, 0,PASS
167, 0,12.65E+06, PASS,2.49999E+01,1.97663E-06, 0,PASS
183, 0,12.85E+06, PASS,2.50000E+01,1.94501E-06, 0,PASS
200, 0,13.06E+06, PASS,2.50002E+01,1.91427E-06, 0,PASS
217, 0,12.73E+06, PASS,2.50003E+01,1.96422E-06, 0,PASS
233, 0,12.53E+06, PASS,2.50004E+01,1.99519E-06, 0,PASS
250, 0,12.67E+06, PASS,2.50003E+01,1.97332E-06, 0,PASS
    
```

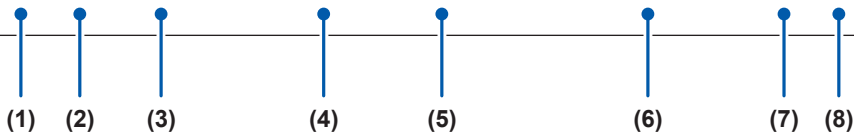

- (1) Time stamp (ms)
- (2) Measurement status
- (3) Resistance value (Ω)
- (4) Judgment result
- (5) Voltage value (V)
- (6) Current value (A)
- (7) BDD result
- (8) Contact check result

4.5 Ending the Test

The test is ended in any of the following situations.

- Press the **STOP** key.
- Turn ON the EXT.I/O stop signal.
- The set test time elapses.
- The test mode is set to the PASS STOP mode and a PASS judgment is made.
- The test mode is set to the FAIL STOP mode and a FAIL judgment is made.
- When the contact check function is ON, the contact check result is FAIL.
- When BDD stop function is ON, the BDD count is 1 or more.
- Send the **:STOP** command.
- The interlock activates.

WARNING



- **After the test is ended, remove the test leads from the DUT when the TEST indicator turns off.**

Otherwise, electric shock accidents may occur.

The measured value displayed immediately before the end of the test and the COMP are still displayed.

Even after the test is ended, the TEST indicator does not turn off but is lit dimly in some cases. This indicates that the charge remaining inside the DUT and instrument is still being discharged. Discharge any remaining electric charge according to “4.6 Discharging Residual Electric Charge (Auto Discharge Function)” (p. 56).

Remove the test leads after the TEST indicator turns off.

4.6 Discharging Residual Electric Charge (Auto Discharge Function)

This instrument can discharge residual electric charge through the internal circuit.

WARNING



- **If the DUT contains capacitance, discharge the DUT using the discharge function of the instrument before starting an insulation resistance test.**

Since the DUT is still charged with electric charge equivalent to the test voltage due to capacitance, electric shock accidents may occur.

Discharge the DUT according to the following procedure after the test.

- 1 End the test with the test leads in contact with the DUT.**
- 2 While the TEST indicator is lit dimly, keep the test leads connected to the DUT.**
The electric charge remaining in the DUT is automatically discharged inside of the instrument (the TEST indicator is lit dimly).
When the voltage drops below 1 V or so, the TEST indicator turns off.
- 3 Remove the test leads from the DUT after the TEST indicator turns off.**

5 Various Functions

The functions that come with this instrument are described here.

Checks for any contact defects and confirms the contact condition.	▶ “5.1 Checking for Any Contact Defects and Confirming Contact Condition (Contact Check Function)” (p. 58)
Detects micro insulation failure.	▶ “5.2 Detecting Micro Insulation Failure (BDD Function)” (p. 60)
Limits the current to be applied to the DUT	▶ “5.3 Limiting the Current to Be Applied to the Device Under Test (DUT)” (p. 64)
Issues the key operation sound. Mutes the key operation sound.	▶ “5.4 Setting Whether to Turn ON or OFF the Key Operation Sound” (p. 67)
Enables the key operations. Disables the key operations.	▶ “5.5 Enabling/Disabling the Key Operations” (p. 68)
Increases the screen contrast. Decreases the screen contrast.	▶ “5.6 Adjusting the Screen Contrast” (p. 72)
Increases the brightness of the backlight. Decreases the brightness of the backlight.	▶ “5.7 Adjusting the Backlight” (p. 73)
Manually sets the frequency of the power supply.	▶ “5.8 Manually Setting the Frequency of the Power Supply” (p. 74)
Restores the instrument to the factory settings.	▶ “5.9 Initializing the Instrument (Reset)” (p. 75) ▶ “11.9 Default Setting” (p. 214)

The following information is provided in other chapters:

Shuts down the output of the instrument.	▶ “2.6 Shutting Down the Output of the Instrument (Interlock Function)” (p. 32)
Judges the measured value based on the threshold value.	▶ “3.6 Judging the Measured Value (Comparator Function)” (p. 44)
Notifies the judgment result and test completion with a beep.	▶ “3.8 Notifying the Judgment Result and Test Completion with a Beep” (p. 47)
Saves the measured conditions in the memory of the instrument.	▶ “6 Saving and Loading Measurement Conditions (Panel Save and Load Functions)” (p. 77)
Automatically sends the measured value every time the test is completed.	▶ “8.5 Automatically Sending the Measured Value Every Time a Test Is Completed (Auto Data Output Function)” (p. 111)
Displays commands and response messages on the Measurement screen.	▶ “8.6 Communications Command Display (Command Monitor Function)” (p. 112)

5.1 Checking for Any Contact Defects and Confirming Contact Condition (Contact Check Function)

When the contact check function is enabled, the connection between the HIGH terminal and LOW terminal can be checked.

When the test leads are off of the DUT, a contact error occurs and **[Contact FAIL]** is displayed.

When **[Contact FAIL]** is displayed, a contact defect is suspected. Check the contact of the tip of the test leads and any disconnection of the test leads.

If the measured capacitance value is greater than 200 nF, **[OVER]** is displayed, and the contact check judgment is PASS. The contact check judgment results can be checked with the setting screen, communications command, and EXT. I/O.

Good contact

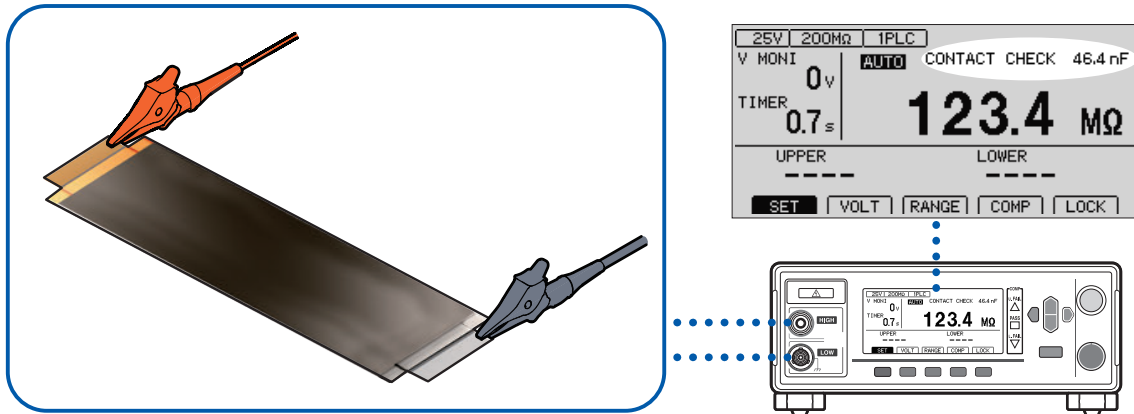

Contact defect

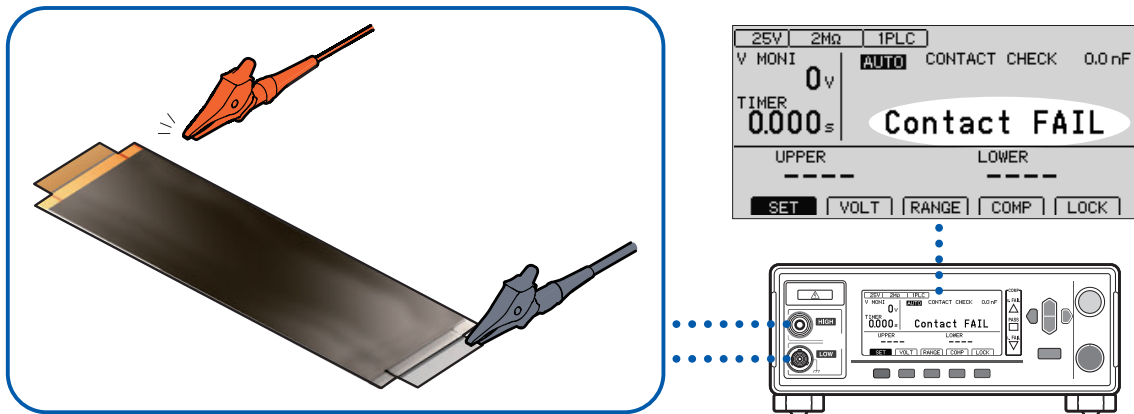

Timing of a contact check

Perform a contact check after the test starts and before a voltage is applied.

Threshold value

- The threshold value of a contact check is set as an electrostatic capacitance value for this instrument. It can be selected in the range between 0.1 nF and 100 nF.
- Contact check judgments are generated by comparing the set threshold value with the DUT's electrostatic capacitance value. When the electrostatic capacitance between the HIGH terminal and LOW terminal is below the threshold value, the display will show **[Contact FAIL]**. Insulation resistance measurement or judgment is not performed.

1 Open the Setting screen.

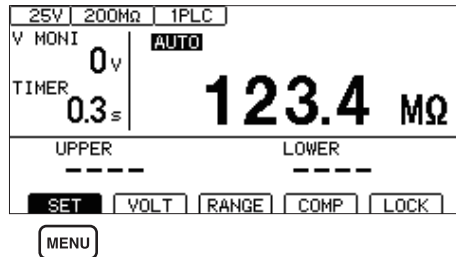

[MENU] Select

2 Set the contact check function.

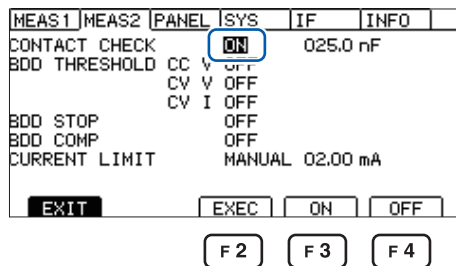

[SELECT] Select

[F2] **[EXEC]** Execute a contact check

[F3] **[ON]** Contact check function ON

[F4] **[OFF]** Contact check function OFF

3 Set the judgment threshold value of the contact check.

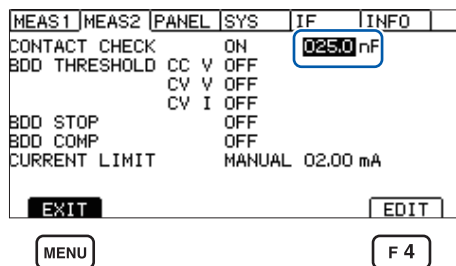

[SELECT] Select

[F4] **[EDIT]** Edit

[SELECT]

- Change the value (up/down keys)
- Change the cursor position (left/right keys)

[ENTER] Confirm

[MENU] **[EXIT]** Return to the Measurement screen

5.2 Detecting Micro Insulation Failure (BDD Function)

The Break Down Detect (BDD) function detects micro voltage or current change during a test. As it detects a change to the voltage or current, dropped detection due to insufficient sampling speed can be reduced.

Using the BDD function allows you to detect micro insulation failure due to contamination (mixing of metal foreign substances), etc.

The number of times the amount of change in voltage or current exceeded the set threshold value as well as the amount of change in the voltage and current each time are recorded in the instrument's memory (up to 99 sets of data).

The detection results can be checked on the Measurement screen, communications command, and EXT. I/O.

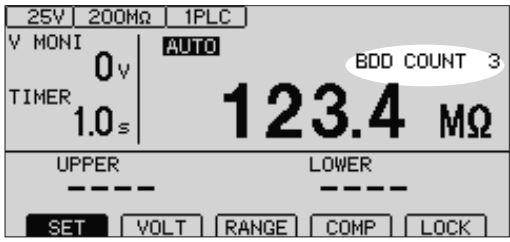
Measurement screen	<p>You can check the BDD count on the Measurement screen.</p> 
Communications command	<p>You can check the BDD count with the <code>:BDD:COUNT?query</code> (p. 149). You can check the time stamp at which BDDs were detected with the <code>:BDD:MEMory?</code> query (p. 150), along with the detection timing (CCV, CVV, CVI), amount of voltage change, and amount of current change.</p>
EXT. I/O	<p>You can use No. 13 (BDD) pin to check if the BDD count was more than or equal to 1.</p>

The following detection methods are available for the BDD function. It is recommended to use settings of 1 V and 1% or more as measurement can be affected by the external environment.

CC V mode	<p>Detects insulation failure using the voltage value (V) during charging. A judgment is made for the voltage value immediately before it changes.</p> <p>Settable range: 0.1 V to 500.0 V</p>
CV V mode	<p>Detects insulation failure using the voltage value (V) in the steady state after charging. A judgment is made for the voltage (stabilized voltage) in the steady state.</p> <p>Settable range: 0.1 V to 500.0 V</p>
CV I mode	<p>Detects insulation failure using a change to the current (%) in the steady state after charging. A proprietary reference value has been established for each range. The judgment threshold value is set as a percentage of that reference value. Evaluate a known-good part in the operating environment and set the threshold at which no BDD count occurs.</p> <p>Settable range: 0.6% to 999.9%</p>

IMPORTANT

The BDD function's detection precision decreases when switching ranges during auto-range operation. It is recommended to set the range manually.

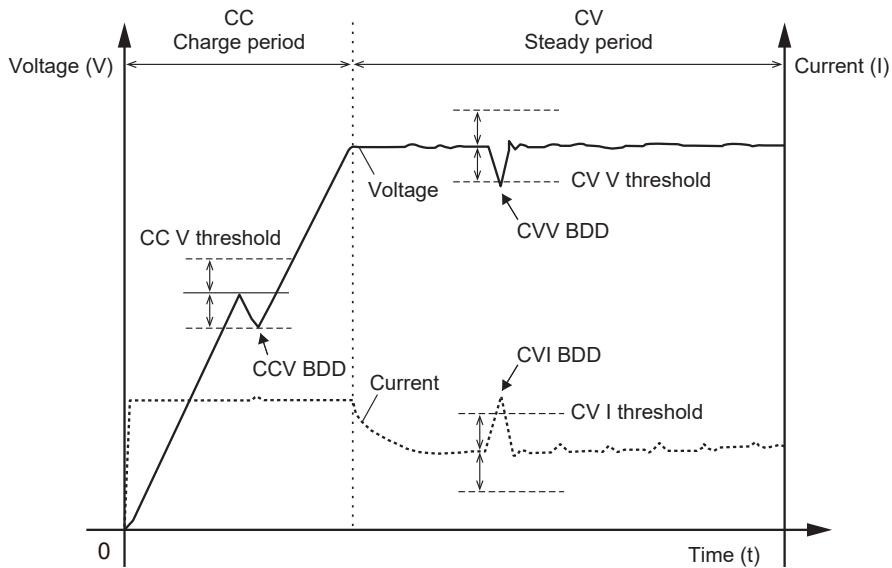

Enabling the BDD function and setting the threshold value

- 1 Open the Setting screen.

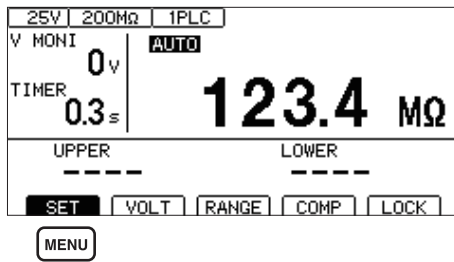

[MENU] [SET] Select

- 2 Specify the ON/OFF setting for each BDD function.

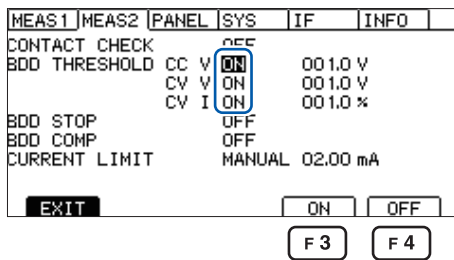

[Left/Right Arrow] Select

[F3] [ON]

[F4] [OFF]

- 3 Set the threshold value for each BDD function.

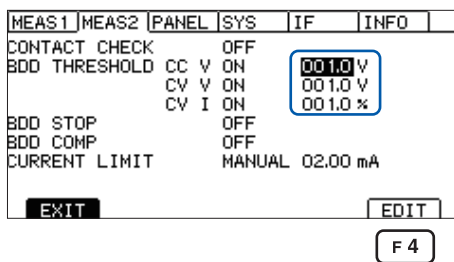

[Left/Right Arrow] Select

[F4] [EDIT] Edit

[Left/Right Arrow] • Change the value (up/down keys)
 [Left/Right Arrow] • Change the cursor position (left/right keys)

[ENTER] Confirm

Enabling the BDD stop function

When the BDD stop function is enabled, the instrument will automatically stop testing when the BDD count reaches or exceeds 1. Since the output voltage will also be stopped, this function helps ensure testing safety.

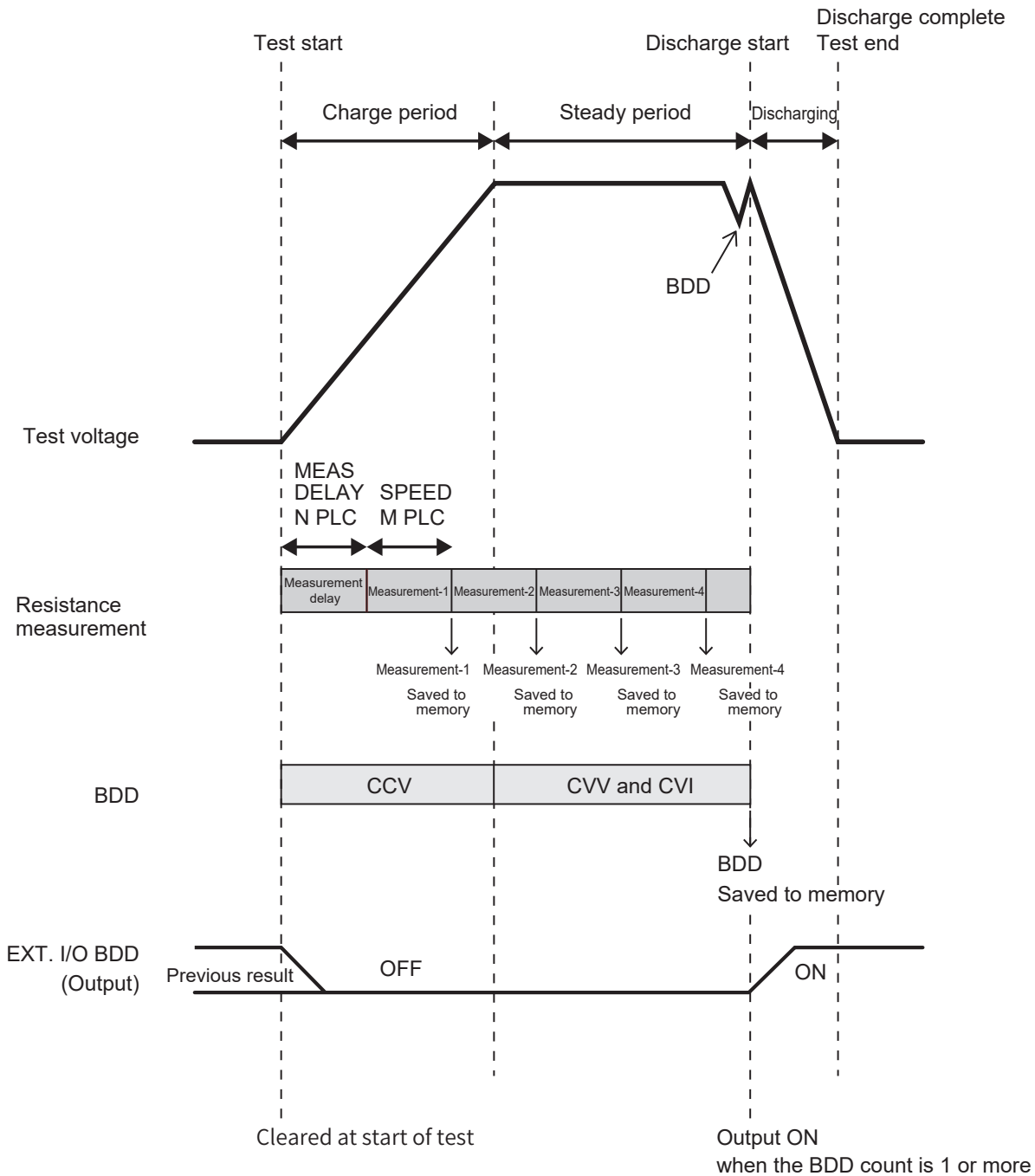

- When testing starts, resistance measurement starts in accordance with the sampling time setting (1 PLC to 100 PLCs).
- When one measurement completes, the measured value is saved to memory.
- BDD events are detected in accordance with either the CCV settings (during the charging period) or the CVV and CVI settings (during the steady-state period).
- If the BDD count reaches or exceeds 1, the output voltage will stop, and the instrument will enter the discharge state. In addition, the EXT. I/O BDD output will turn on.
- In the above example, four measured values have been saved to memory, and one BDD measured value has been saved to BDD memory, since the BDD stop function activated to end testing during the fifth measurement.

1 Open the Setting screen.

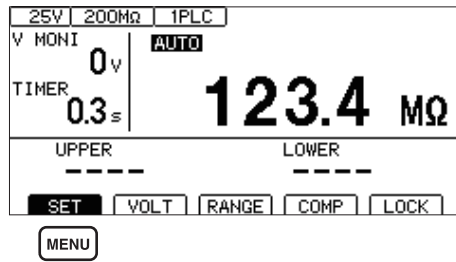

[MENU] **[SET]** Select

2 Specify the ON/OFF setting for the BDD stop function.

If the BDD stop function is enabled, the test is ended if the BDD count reaches or exceeds 1.

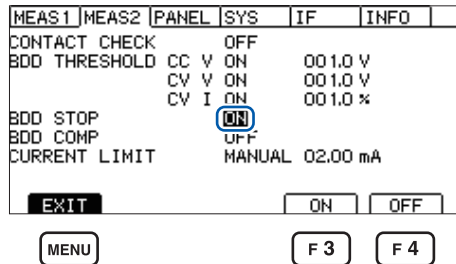

Select

F3 **[ON]**

F4 **[OFF]**

[MENU] **[EXIT]** Return to the Measurement screen

Enabling BDD judgment

When BDD judgment and the comparator function are both enabled, a BDD count of 1 or greater yields a judgment of U. FAIL and L. FAIL. If the BDD count is 0, the measured value is judged according to the upper and lower limit value settings for insulation resistance.

See “3.6 Judging the Measured Value (Comparator Function)” (p. 44).

1 Open the Setting screen.

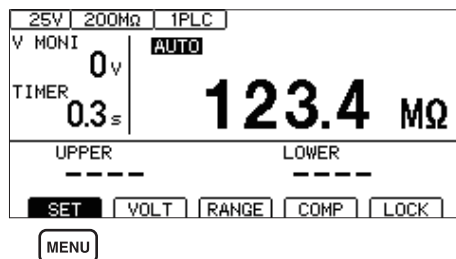

[MENU] **[SET]** Select

2 Enable or disable BDD judgment.

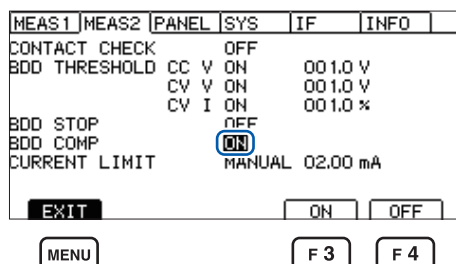

Select

F3 **[ON]**

F4 **[OFF]**

[MENU] **[EXIT]** Return to the Measurement screen

5.3 Limiting the Current to Be Applied to the Device Under Test (DUT)

The current to be applied to the DUT can be limited (current limit function).

50 μ A to 0.99 mA	10 μ A resolution
1.0 mA to 50.0 mA	100 μ A resolution

The charging time for the capacitive load can be shortened. It is also possible to reduce the risk which the DUT can be damaged or destroyed.

The current limit value can be set manually or automatically.

When setting the current limit value automatically, it will be automatically calculated based on the test voltage, the charging time, and the DUT's electrostatic capacitance value.

Calculating formula

$$\text{Current limit value (A)} = \frac{\text{Electrostatic capacitance value (F)} \times \text{Test voltage (V)}}{\text{Charging time (s)}}$$

The DUT's electrostatic capacitance value can be either set manually (MANUAL) or measured and set automatically at the start of testing (AUTO).

Current limit	CURRENT LIMIT setting	CHARGE TIME setting	DUT CAPACITY setting	Operation	Applications
Manual	MANUAL, current limit value	–	–	Limits the current applied to the current value set with the CURRENT LIMIT setting.	Use when you wish to limit the applied current to a user-specified value.
Auto	AUTO	Charging time	MANUAL, electrostatic capacitance value	Limits the current applied to the current value calculated based on the test voltage, the charging time (as set by CHARGE TIME), and the DUT's electrostatic capacitance value (as set by DUT CAPACITY).	Use when you wish to limit the applied current to a user-specified charging time for a DUT whose electrostatic capacitance value is known.
			AUTO	Limits the current applied to the current value calculated based on the test voltage, the charging time (as set by CHARGE TIME), and the electrostatic capacitance value as measured at the start of the test. Since electrostatic capacitance measurement is the same type of measurement as performed by the contact check function, the test time will increase by the electrostatic capacitance measurement time. In addition, the contact check signal will be applied to the DUT at the start of the test.	Use when you wish to limit the applied current to a user-specified charging time for a DUT whose electrostatic capacitance value is not known.

Setting the current limit value manually

1 Open the Setting screen.

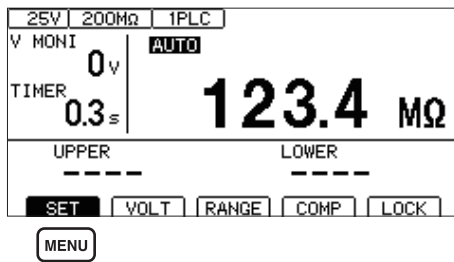

MENU [SET] Select

2 Set [CURRENT LIMIT] to [MANUAL].

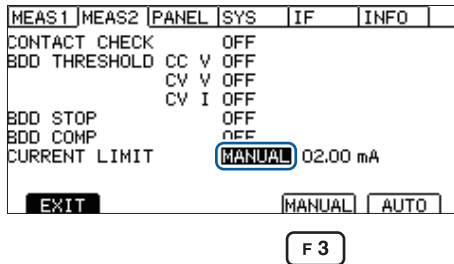

Select

F 3 [MANUAL] Select

3 Set [CURRENT LIMIT] to the edit mode.

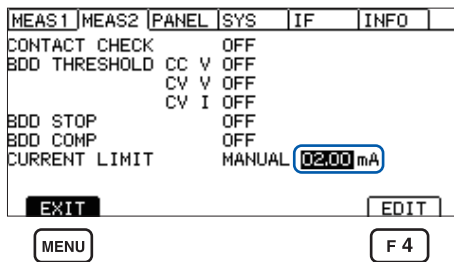

Select

F 4 [EDIT] Edit

• Change the value (up/down keys)
 • Change the cursor position (left/right keys)

ENTER Confirm

MENU [EXIT] Return to the Measurement screen

IMPORTANT

- If the set current limit value is from 5.1 mA to 50.0 mA, the current will be limited to 5 mA after the output voltage reaches the set voltage.
- If a capacitive load of approximately 50 μF or more is connected while the current limit value of 5.1 mA or more, constraints related to the output generator will result in an error, making measurement impossible.

See “9.2 Input, Output, and Measurement Specifications” (p. 180)

Setting the current limit value automatically

1 Open the Setting screen.

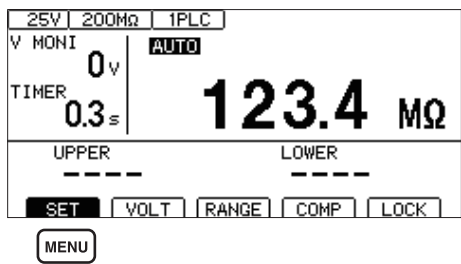

[MENU] **[SET]** Select

2 Set **[CURRENT LIMIT]** to **[AUTO]**.

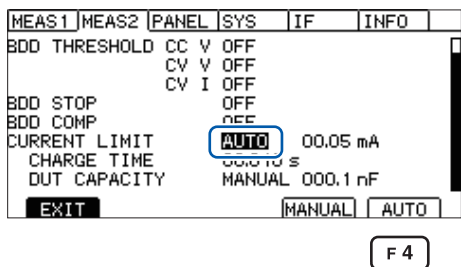

Select

F 4 **[AUTO]** Select

3 Set charging time **[CHARGE TIME]**.

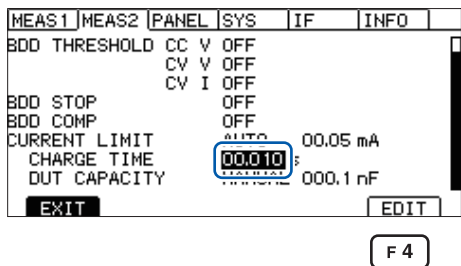

Select

F 4 **[EDIT]** Edit

• Change the value (up/down keys)
 • Change the cursor position (left/right keys)

[ENTER] Confirm

4 Set **[DUT CAPACITY]**.

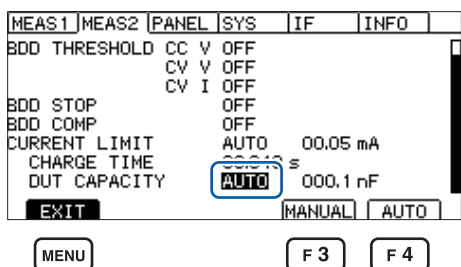

Select

F 3 **[MANUAL]**

F 4 **[AUTO]**

[MENU] **[EXIT]** Return to the Measurement screen

IMPORTANT: Charging time

Charging may take longer than the set charging time (**[CHARGE TIME]**) depending on the DUT's capacitance component. This can be addressed by either of the following steps:

- Set a shorter charging time (**[CHARGE TIME]**).
- Set the **[CURRENT LIMIT]** to **[MANUAL]** and adjust the current limit value to achieve the desired charging time.

Factors which can cause charging to take longer than the set charging time include the instrument's internal load and the current limit circuit's response time.

5.4 Setting Whether to Turn ON or OFF the Key Operation Sound

You can set whether to turn ON or OFF the key operation sound.
The key operation sound is set to ON in the default setting.

1 Open the Setting screen.

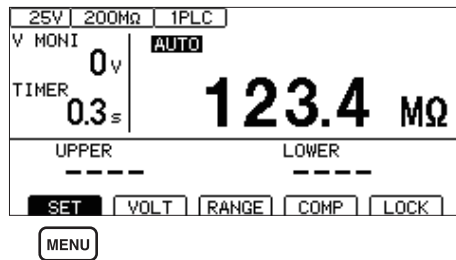

[MENU] [SET] Select

2 Set [KEY CLICK].

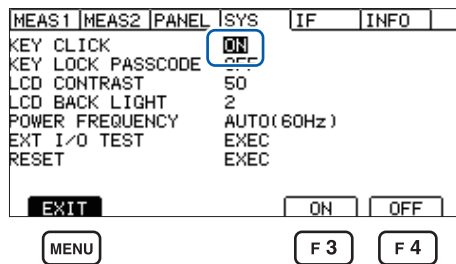

Select

[F 3] [ON]

[F 4] [OFF]

[MENU] [EXIT] Return to the Measurement screen

Set the judgment beep with [COMP BEEP].

See “3.8 Notifying the Judgment Result and Test Completion with a Beep” (p. 47)

A beep will be issued when an error dialog or information dialog is displayed, even if the [KEY CLICK] setting is disabled.

5.5 Enabling/Disabling the Key Operations

Executing the key lock function can disable the key operations except for **UNLOCK**, **START**, and **STOP**.

This function provides a simple way to prevent unintentional changes to the measurement conditions.

Disabling the key operations (key lock)

Execute the key lock.

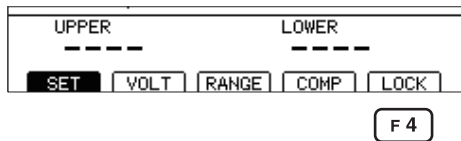

F 4 **[LOCK]** Execute the key lock

[LOCK] is displayed at the upper right and the key operations except for **UNLOCK**, **START**, and **STOP** are disabled.

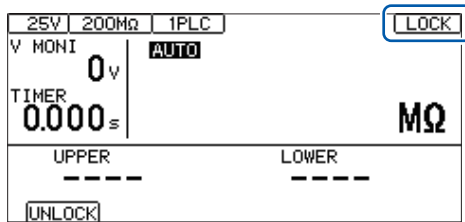

Enabling the key operations (releasing key lock)

Release the key lock.

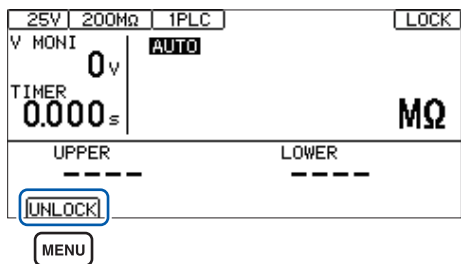

MENU **[UNLOCK]** Release the key lock (Press for 1 second.)

[LOCK] at the upper right disappears and the key functions become enabled.

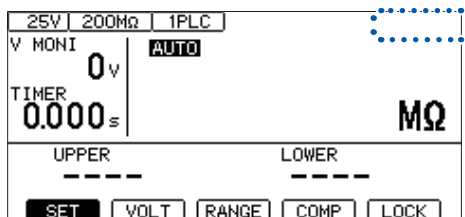

Enabling the key lock function with a passcode

When this function is enabled, the instrument requires the passcode to release the key lock. If the set passcode and entered passcode match, the key lock is released.

This function prevents the operators from accidentally changing the measurement conditions.

Setting a passcode

- 1 Open the Setting screen.

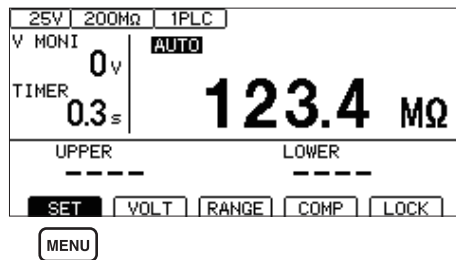

MENU **[SET]** Select

- 2 Set **[KEY LOCK PASSCODE]** to **[ON]**.

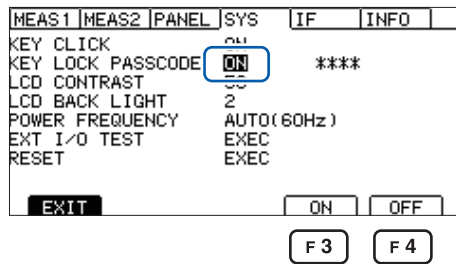

Select

F3 **[ON]**
F4 **[OFF]**

When it is set to ON, **[****]** is displayed regardless of the number of passcode characters.

- 3 Move the cursor to **[****]** and press the **[EDIT]** key.

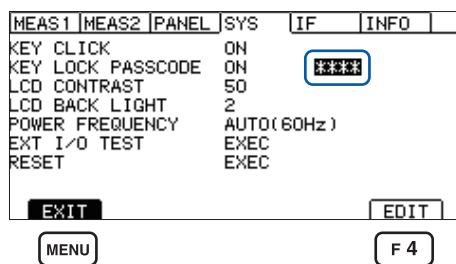

F4 **[EDIT]** Edit

MENU **[EXIT]** Return to the Measurement screen

The passcode setting dialog box is displayed.

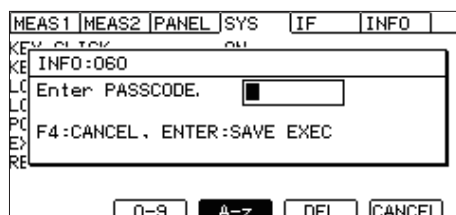

The default setting is "" (none).

4 Enter and confirm a passcode.

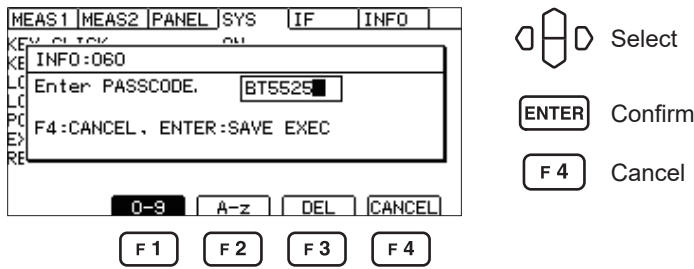

A passcode can be set between 0 and 8 characters. Once the passcode is set, it is retained even when the power is turned off.

Key operations when the passcode is entered

Key	Operation
	Moves the cursor.
	Changes alphabetic characters and numbers.
F 1	Enters 0 to 9.
F 2	Enters alphabetic characters and underscores (_).
F 3	Deletes characters.

No key click will sound during passcode entry.

Disabling the key lock function with a passcode

1 Open the Setting screen.

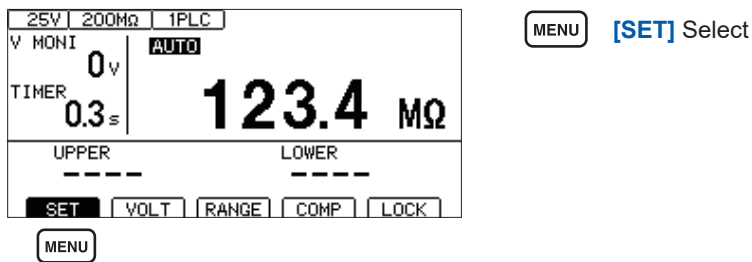

2 Set [KEY LOCK PASSCODE] to [OFF].

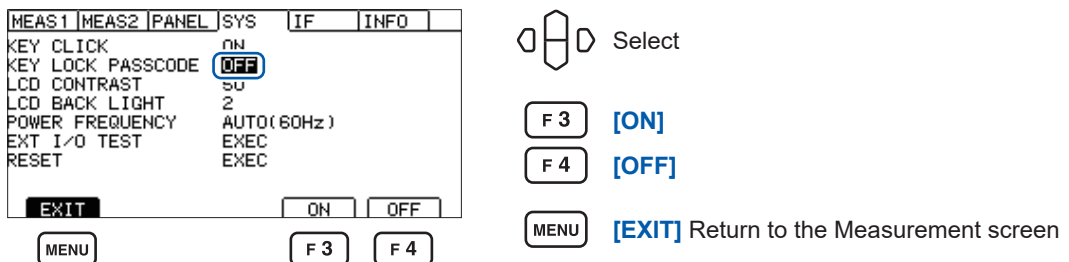

Once the passcode is set, it is retained even when the power is turned off.

Releasing the key lock by entering the passcode

Executing the key lock is the same as the normal key lock function.
See “Disabling the key operations (key lock)” (p. 68).

1 Release the key lock.

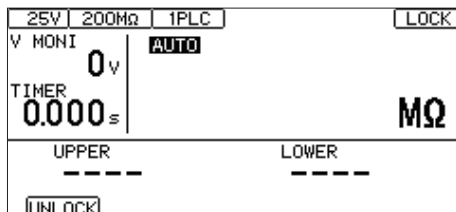

MENU

MENU

[UNLOCK]

Display the passcode input dialog box

2 Enter and confirm a passcode.

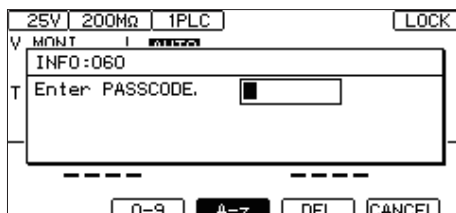

F1 F2 F3 F4

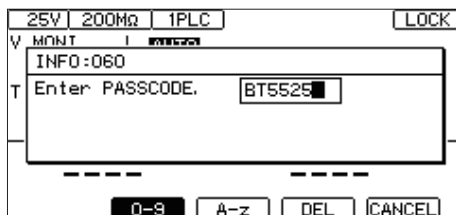

F1 F2 F3 F4

ENTER

Confirm

If the set passcode and entered passcode match, [LOCK] at the upper right disappears and the key operation is enabled.

Unless the set passcode and entered passcode match, the key lock cannot be released.



F1 F2 F3 F4

IMPORTANT

- If you forget the passcode, use either of the following communications commands:
- Querying and reconfiguring the passcode “Querying the key lock passcode” (p. 159)
 - Resetting the system “Changing the settings to the default settings (except for the communications settings)” (p. 131)

5.6 Adjusting the Screen Contrast

The screen contrast can be set in 5 increments between 0 and 100.

IMPORTANT

When the ambient temperature fluctuates, the screen may be difficult to see.

1 Open the Setting screen.

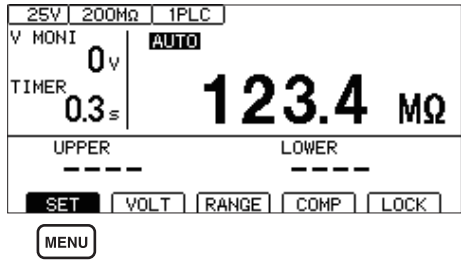

MENU [SET] Select

2 Set [LCD CONTRAST].

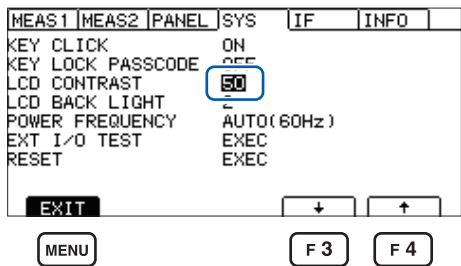

Select

F 3 [↓] Decrease the screen contrast

F 4 [↑] Increase the screen contrast

MENU [EXIT] Return to the Measurement screen

5.7 Adjusting the Backlight

The brightness of the backlight can be adjusted according to the lighting of the installation location. The setting range is from 0 to 3.

IMPORTANT

Using a communications command (:DISPlay:BACKlight) is the only way to set the brightness of the backlight to "0". If the brightness of the backlight is set to "0", however, the display is difficult to see.

1 Open the Setting screen.

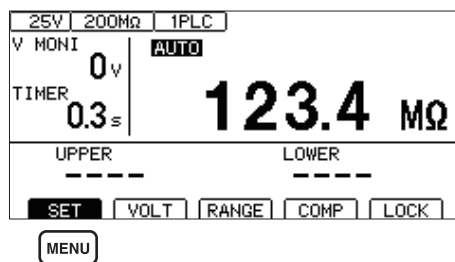

MENU **[SET]** Select

2 Set [LCD BACK LIGHT].

The smaller the number is, the lower the brightness becomes.

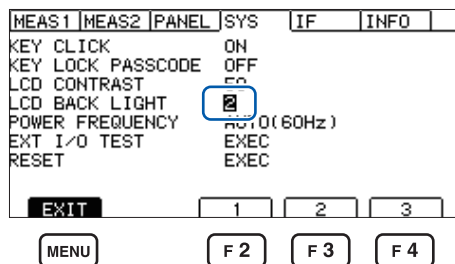

◀ ▶ Select

F 2 **[1]** Dark

F 3 **[2]** Standard

F 4 **[3]** Bright

MENU **[EXIT]** Return to the Measurement screen

5.8 Manually Setting the Frequency of the Power Supply

There are three frequency settings for the power supply, AUTO, 50 Hz, and 60 Hz.

The power supply frequency needs to be properly set to eliminate noise.

The default setting is **[AUTO]** (the power supply frequency is automatically recognized when the power is turned on), however, the frequency can be manually set as well.

If the power supply frequency is not correctly set, the measured value is not stabilized.

If power supply noise is significant and the power supply frequency cannot be detected properly even when the frequency is set to **[AUTO]**, **[INFO:090 Power line cycle is not detected.,Select power line cycle.]** is displayed when the power is turned on. Set the frequency according to the power supply.

1 Open the Setting screen.

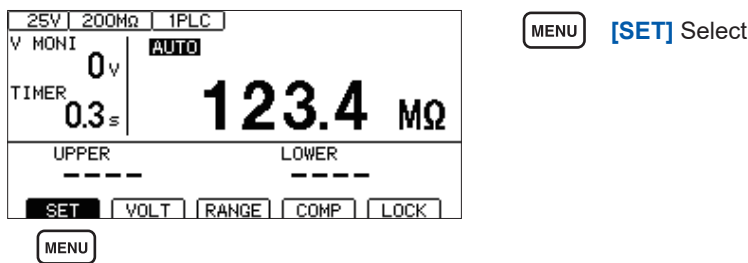

[MENU] **[SET]** Select

2 Set **[POWER FREQUENCY]**.

(When **[AUTO]** is selected, the power supply frequency that is automatically recognized is displayed at the right side.)

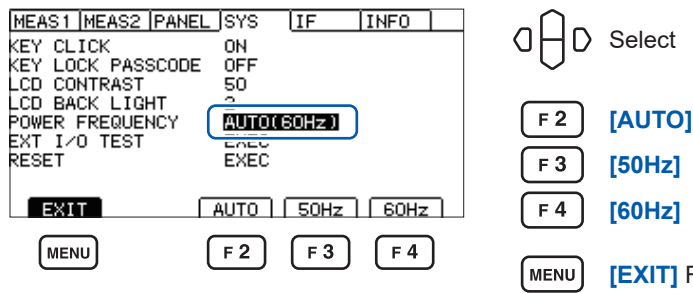

[Left Arrow] **[Up Arrow]** **[Down Arrow]** Select

[F 2] **[AUTO]**

[F 3] **[50Hz]**

[F 4] **[60Hz]**

[MENU] **[EXIT]** Return to the Measurement screen

IMPORTANT

Automatic recognition of the power supply frequency is performed only once when the power is turned on.

When the frequency is changed from **[50Hz]** or **[60Hz]** to **[AUTO]**, turn off the power and then turn on the power again.

5.9 Initializing the Instrument (Reset)

All measurement conditions and panel data are initialized to the factory settings.
See “11.9 Default Setting” (p. 214).

There are two ways to reset the instrument.

- (1) Resetting in the System Setting screen
- (2) Resetting using a communications command
 - *RST command or :SYSTEM:RESet command (The interface settings are not reset.)

The procedure for resetting the data in the System Setting screen is explained in this section.

1 Open the Setting screen.

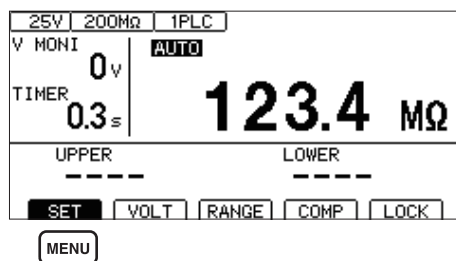

MENU [SET] Select

2 Execute [RESET].

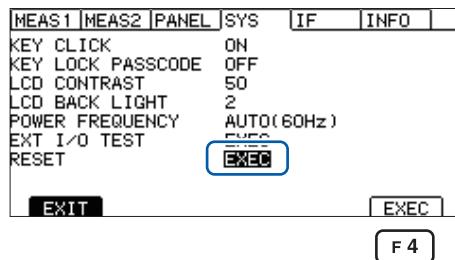

Select

F4 [EXEC] Execute

3 Select [OK].

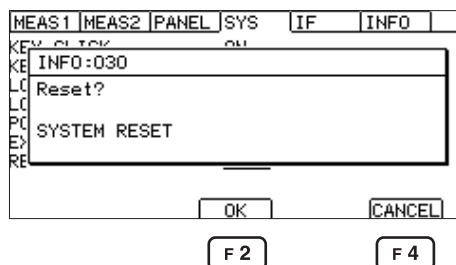

F2 [OK]

F4 [CANCEL] Cancel

6

Saving and Loading Measurement Conditions (Panel Save and Load Functions)

The measurement conditions can be saved in the memory of the instrument and loaded as necessary.

Panel save function	<p>The current measurement conditions can be saved. Up to 15 different measurement conditions can be saved and retained even when the power is turned off.</p> <p>► Items that can be saved using the panel save function See “11.9 Default Setting” (p. 214).</p>
Panel load function	<p>► The saved measurement conditions are loaded from the memory of the instrument.</p>

6.1 Saving Measurement Conditions (Panel Save Function)

Up to 15 current measurement conditions can be saved in the memory of the instrument.

1 Open the Setting screen.

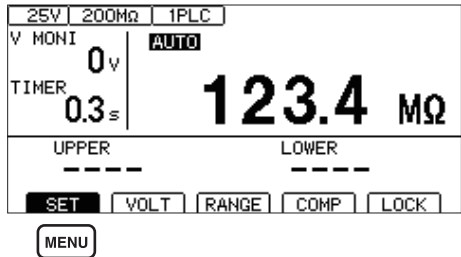

MENU [SET] Select

2 Select the panel number to be saved.

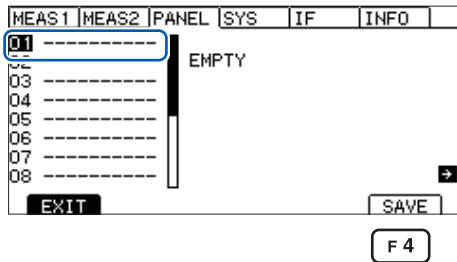

Select

F 4 [SAVE] Save

3 Enter and confirm the panel name.

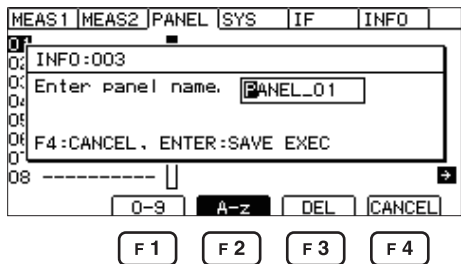

Select

ENTER Confirm

F 4 [CANCEL] Cancel

Key operations when the panel name is entered

Key	Operation
	Moves the cursor.
	Changes alphabetic characters and numbers.
F 1	Enters 0 to 9.
F 2	Enters alphabetic characters and underscores (_).
F 3	Deletes characters.

6.2 Loading Measurement Conditions (Panel Load Function)

The saved measurement conditions are loaded from the memory of the instrument.

1 Open the Setting screen.

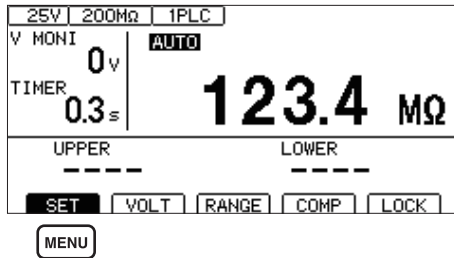

MENU [SET] Select

2 Select the panel number and load the data.

The saved description is displayed at the right side of the screen.

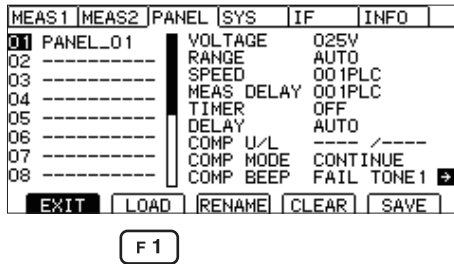

◀ ▶ • Select the panel (up/down keys)
◀ ▶ • Switch the panel page (left/right keys)

F1 [LOAD] Load
Or read using the ENTER key

3 Select [OK] on the confirmation screen, or confirm using ENTER key.

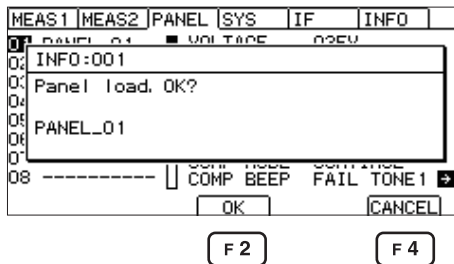

◀ ▶ Select

ENTER Confirm

F2 [OK]

F4 [CANCEL] Cancel

The panel name is displayed on the Measurement screen.

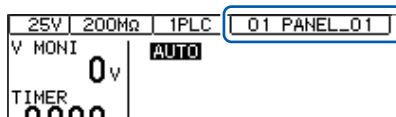

IMPORTANT

The conditions can be loaded using the EXT.I/O (LOAD0 to LOAD3 and LOAD_VALID control) or communications command (*RCL).

When the measurement conditions are changed after they are loaded, the panel name disappears from the display.

6.3 Changing the Panel Name

The saved panel names can be changed.

1 Open the Setting screen.

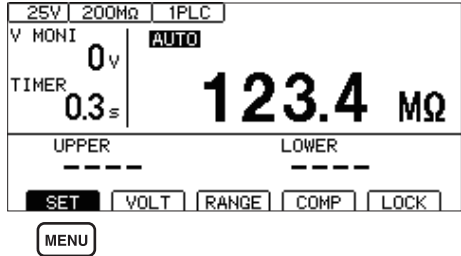

 **[SET]** Select

2 Select the panel number and select **[RENAME]**.

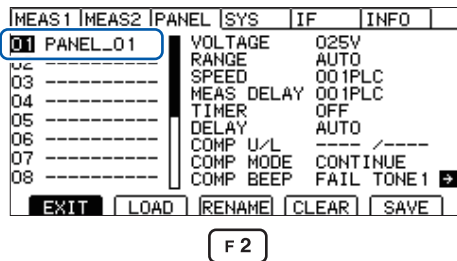

 Select

 **[RENAME]**

3 Change and confirm the panel name.

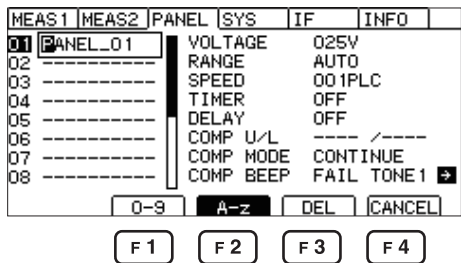





 Select

 Confirm

 **[CANCEL]** Cancel

Key operations when the panel name is entered

Key	Operation
	Moves the cursor.
	Changes alphabetic characters and numbers.
	Enters 0 to 9.
	Enters alphabetic characters and underscores (_).
	Deletes characters.

6.4 Deleting Panel Data

The measurement conditions saved using the panel save function can be deleted.

1 Open the Setting screen.

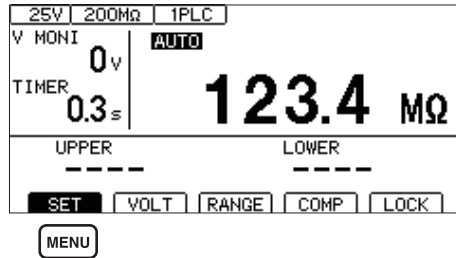

MENU [SET] Select

2 Select the number of the panel to be deleted.

The panel description is displayed at the right side of the screen.

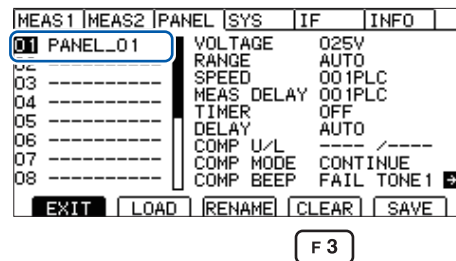

Select

F3 [CLEAR] Delete

3 Select [OK] on the confirmation screen, or confirm using ENTER key.

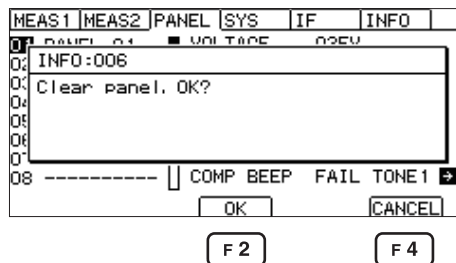

ENTER Confirm

F2 [OK]

F4 [CANCEL] Cancel

IMPORTANT
Deleted panels cannot be recovered.

7

External Control (EXT. I/O)

This instrument can be controlled when the EXT. I/O connector on the back of the instrument is used to output test and judgment result signals and input START and STOP signals, etc. All signals are isolated with a photocoupler (the common terminal is shared for input and output). The input circuit can be switched for current sink output (NPN) or current source output (PNP) in the internal settings.

Check the input/output rating and internal circuit configuration. After understanding the safety precautions, connect the control system and use the instrument correctly.

DANGER



- **Do not input any voltage/current exceeding the maximum input voltage/current to the EXT. I/O connector.**

Doing so can cause damage to the instrument, resulting in serious bodily injury.

WARNING



- **Do not input any external power to the EXT. I/O connector of the instrument.**

External power cannot be input to the EXT. I/O connector of the instrument. The ISO_5 V terminal of the EXT. I/O has 5 V (NPN)/-5 V (PNP) power output. The instrument can be damaged.



- **When connecting an instrument to the EXT. I/O connector of this instrument, secure the connector using screws.**

If the connector comes off during operation and comes in contact with another conductive object, electric shock accidents may occur.
(The interlock cancellation jig is not secured in place with screws.)

CAUTION



- **Do not short the ISO_5 V and ISO_COM.**
- **When connecting a relay coil to the EXT. I/O output terminal, connect a counter-electromotive force absorbing diode.**

The instrument can be damaged.

- **Follow the procedure below before wiring the EXT. I/O connector.**

1. Turn off the power of this instrument and the instrument to be connected.
2. Discharge static electricity from your body.
3. Check that the signal does not exceed the external input and output rating.
4. Properly isolate this instrument and the instrument to be connected to the EXT. I/O connector terminal.

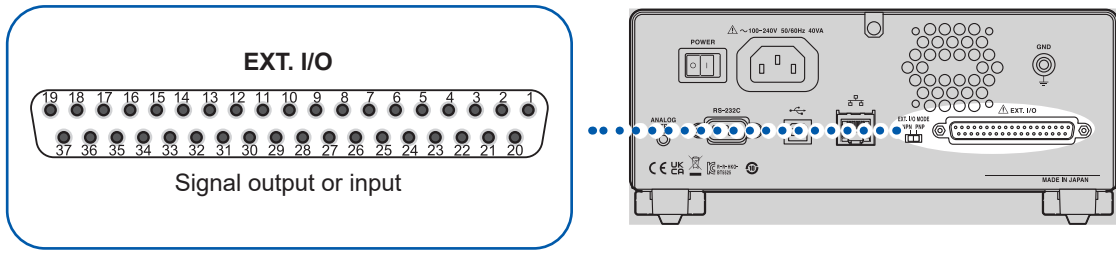

1 Checking the input/output specifications of the controller being used



2 Setting the EXT. I/O MODE switch (NPN/PNP) of the instrument
(After turning off the power of the instrument)

p. 85



3 Connecting the signal output destination or signal input destination to the EXT. I/O connector of the instrument



4 Setting the instrument

7.1 External Input and Output Terminals and Signals

Switching the current sink (NPN) and current source (PNP)

The EXT. I/O MODE switch (NPN/PNP) allows you to change the type of the compatible PLC (programmable logic controller). The EXT. I/O MODE is set to NPN at the time of shipment.

⚠ CAUTION



- Turn off the power of the instrument and then switch the EXT. I/O MODE switch (NPN/PNP).
- Set the NPN/PNP setting according to the instrument to be connected externally.

Otherwise, the instrument connected to the EXT. I/O connector can be damaged.

	EXT. I/O MODE switch (NPN/PNP) setting	
	NPN	PNP
Input circuit	Compatible with sink output	Compatible with source output
Output circuit	Non-polar	Non-polar
ISO_5 V output	+5 V output	-5 V output

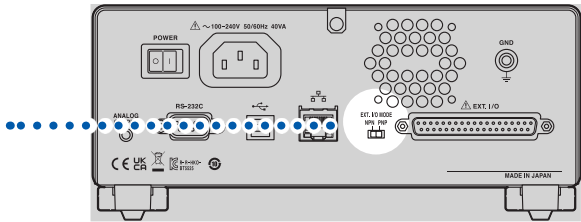
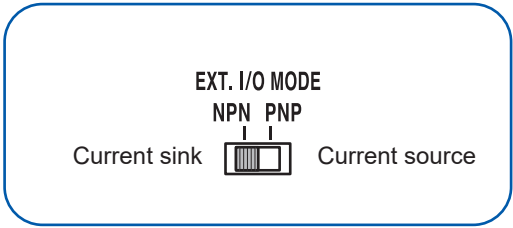

Connector used and signal arrangement

This instrument can be controlled using the EXT. I/O.
 “Input/output test (EXT. I/O test function)” (p. 95) is useful for checking the EXT. I/O input/output.

IMPORTANT
 The connector frame is connected to a metal part on the back of the instrument and protective ground terminal of the power inlet.

Connector used	D-sub 37-pin female #4-40 inch screw
Compatible connector	DC-37P-ULR (soldered type) DCSP-JB37PR (pressure welded type) Japan Aviation Electronics Industry, Ltd.

See “Interface specifications” “(4) EXT. I/O” (p. 187).

Signal functions

Isolated power supply

Pin number	Signal name	EXT. I/O MODE switch (NPN/PNP) setting	
		NPN	PNP
8	ISO_5V	Isolated power supply +5 V	Insulated power supply -5 V
9, 27	ISO_COM	Isolated power supply common	

Input signal

Pin number	Signal name	Function
1	START	Starts a test, and generates output voltage.
20	STOP	Ends a test, and shuts down output voltage.
3	INTERLOCK	<p>Cancels the interlock state.</p> <p>The interlock state is canceled while the signal is at the same potential (ON) as ISO_COM.</p> <p>Placing the signal in the open (OFF) state triggers the interlock, preventing testing from starting.</p> <p>The test is stopped when it turns OFF during the test.</p> <p>See “2.6 Shutting Down the Output of the Instrument (Interlock Function)” (p. 32).</p>
4, 5, 22, 23	LOAD0 to LOAD3	Selects the number of the panel to be loaded.
6	LOAD_VALID	<p>Executes the panel load.</p> <p>[INFO:002 Panel loading...] is displayed during panel load and does not accept any key input.</p>

Output signal

Pin number	Signal name	Function
30	PASS	Outputs when the comparator judgment is PASS.
11	UPPER FAIL	Outputs when the comparator judgment is UPPER FAIL.
12	LOWER FAIL	Outputs when the comparator judgment is LOWER FAIL.
29	C_CHECK_FAIL	Outputs when the contact check judgment is FAIL.
13	BDD	Outputs when the BDD count is 1 or more.
28	TEST	Outputs during a test.
31	VON	Outputs when the voltage monitor value is within $\pm 10\%$ of the set voltage value.
10	SYSTEM_ERR	<p>Outputs when the following errors occur.</p> <ul style="list-style-type: none"> • When an internal temperature error occurs • When a fan error occurs • When a model information error occurs • When a setting backup error occurs

EXT. I/O input and output signals cannot be used while the measurement conditions are being changed inside the instrument.

Panel load signal correspondence table

LOAD0 to LOAD3

Panel number	LOAD3	LOAD2	LOAD1	LOAD0
No load	OFF	OFF	OFF	OFF
1	OFF	OFF	OFF	ON
2	OFF	OFF	ON	OFF
3	OFF	OFF	ON	ON
4	OFF	ON	OFF	OFF
5	OFF	ON	OFF	ON
6	OFF	ON	ON	OFF
7	OFF	ON	ON	ON
8	ON	OFF	OFF	OFF
9	ON	OFF	OFF	ON
10	ON	OFF	ON	OFF
11	ON	OFF	ON	ON
12	ON	ON	OFF	OFF
13	ON	ON	OFF	ON
14	ON	ON	ON	OFF
15	ON	ON	ON	ON

ON/OFF in the above table indicates the status of the external switch (SW) or transistor.

7.2 Timing Chart

7

The level of each signal indicates the ON/OFF status of the contact. When using the current source (PNP) setting, the voltage level is High when contact is ON and Low when contact is OFF. For the voltage level in the current sink (NPN) setting, High and Low are reversed.

IMPORTANT

In the following cases, up to 1 s is added to the START signal detection time.

- The START signal is input after the test voltage is changed.
- The test voltage is changed using the LOAD signal or communications command.

External Control (EXT. I/O)

Timing chart for the continuous test mode

This is the timing chart for measurement performed by inputting the START and STOP signals from the EXT. I/O.

Settings

Test time (TIMER)	OFF or ON
Comparator delay (COMP DELAY)	MANUAL 0.001 s
Test mode (COMP MODE)	CONTINUE
Contact check (CONTACT CHECK)	OFF
BDD	OFF
BDD stop function (BDD STOP)	OFF

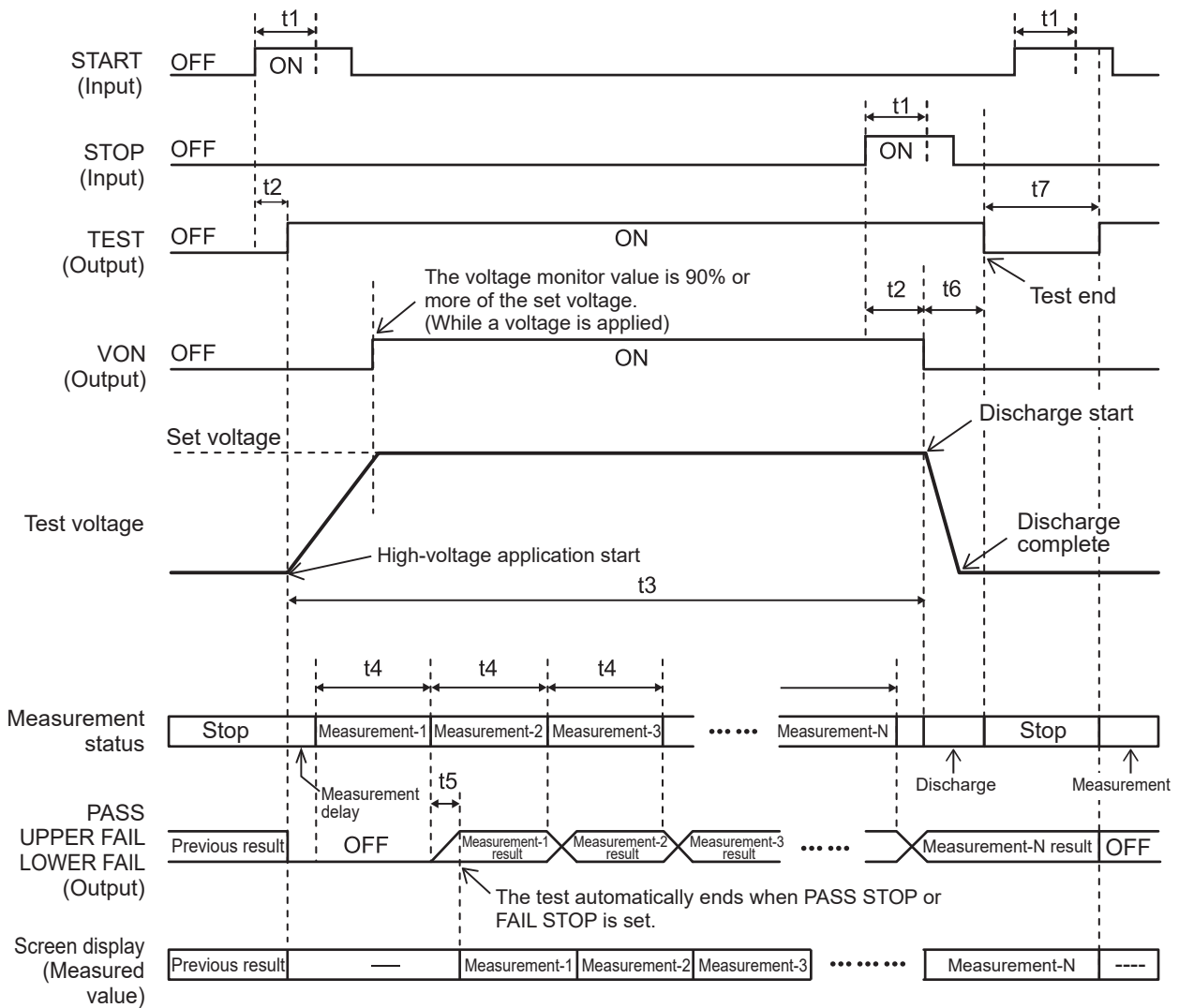

	Description	Time
t1	Pulse width of the START or STOP signal	3 ms min.
t2	Detection time of the START or STOP signal	4 ms max.
t3	Test time	Based on the setting
t4	Measurement time	50 Hz: 20 ms × PLC setting 60 Hz: 16.7 ms × PLC setting
t5	Calculation time	1 ms max.
t6	Discharge time	20 ms max. (at pure resistance measurement)
t7	START setup time	40 ms

Timing chart when the contact check and BDD functions are enabled

This is the timing chart when the contact check and BDD functions are enabled.

Settings

Test time (TIMER)	OFF or ON
Comparator delay (COMP DELAY)	MANUAL 0.001 s
Test mode (COMP MODE)	CONTINUE
Contact check (CONTACT CHECK)	ON
BDD	ON
BDD stop function (BDD STOP)	OFF or ON

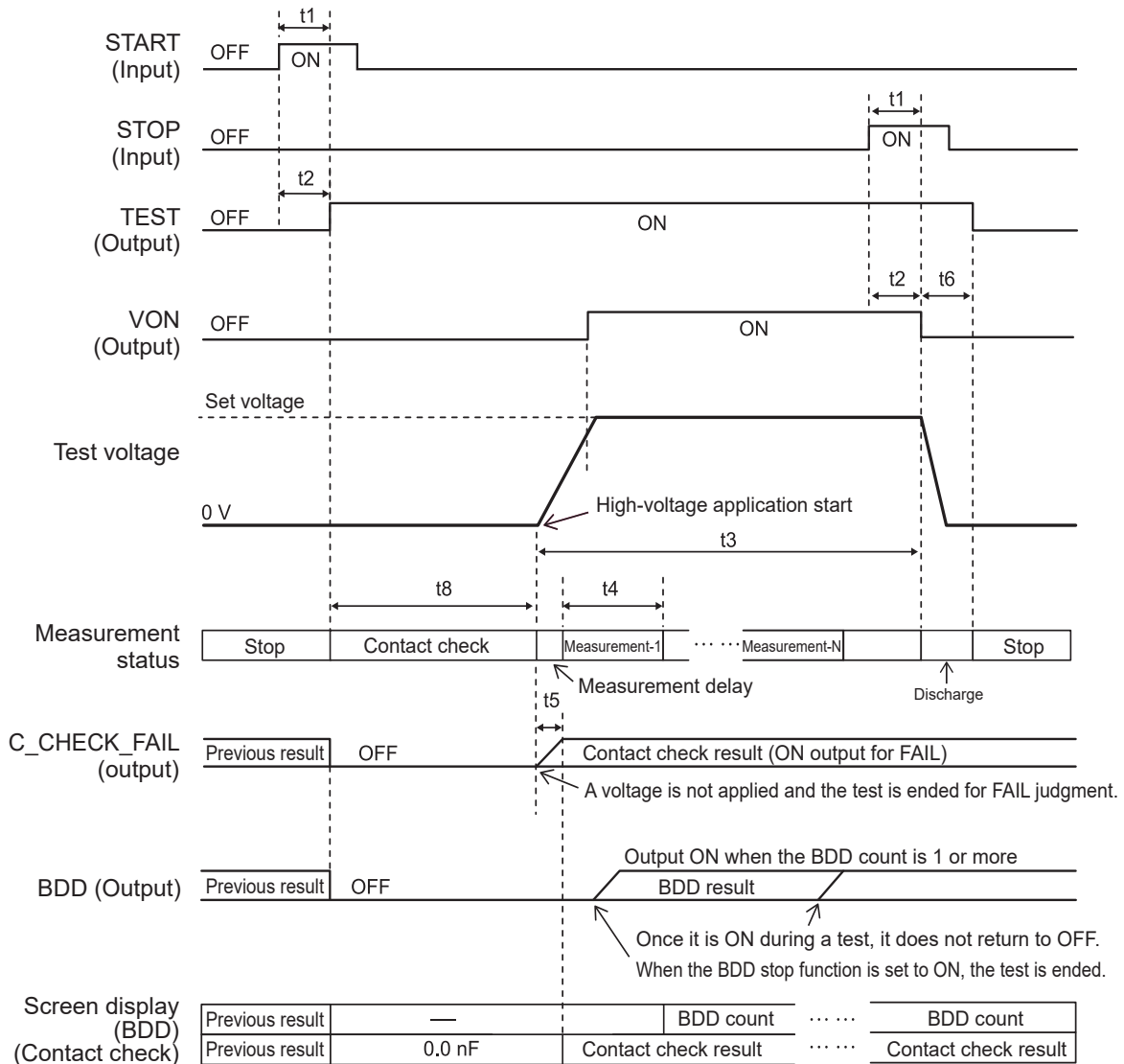

7 External Control (EXT. I/O)

	Description	Time
t1	Pulse width of the START or STOP signal	3 ms min.
t2	Detection time of the START or STOP signal	4 ms max.
t3	Test time	Based on the setting
t4	Measurement time	50 Hz: 20 ms × PLC setting 60 Hz: 16.7 ms × PLC setting
t5	Calculation time	1 ms max.
t6	Discharge time	20 ms max. (at pure resistance measurement)
t8	Contact check time	50 Hz: 50 ms, 60 Hz: 46.7 ms

Timing chart for panel load

When executing the panel load using the EXT. I/O, specify the panel number for LOAD0 to LOAD3 and turn ON LOAD_VALID.

For panel numbers, see the LOAD0 to LOAD3 signal correspondence table.

During panel load operation, the instrument will enter the keylock state, and no key input will be accepted.

In addition, attempting to load a panel during testing will cause a beep to be issued, and the load processing will be ignored.

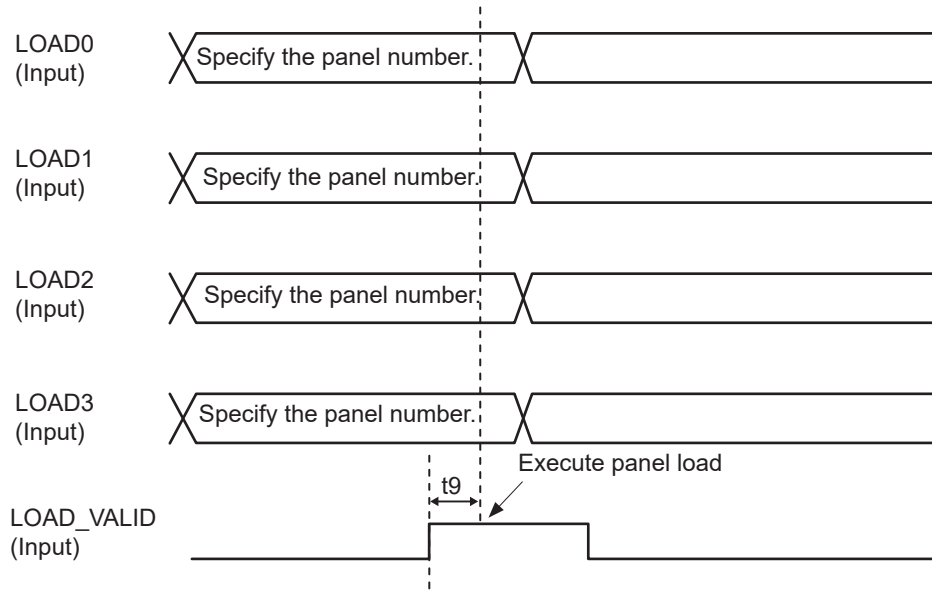

	Description	Time
t9	LOAD_VALID signal detection time	3 ms min.

7.3 Internal Circuit Configuration

NPN setting

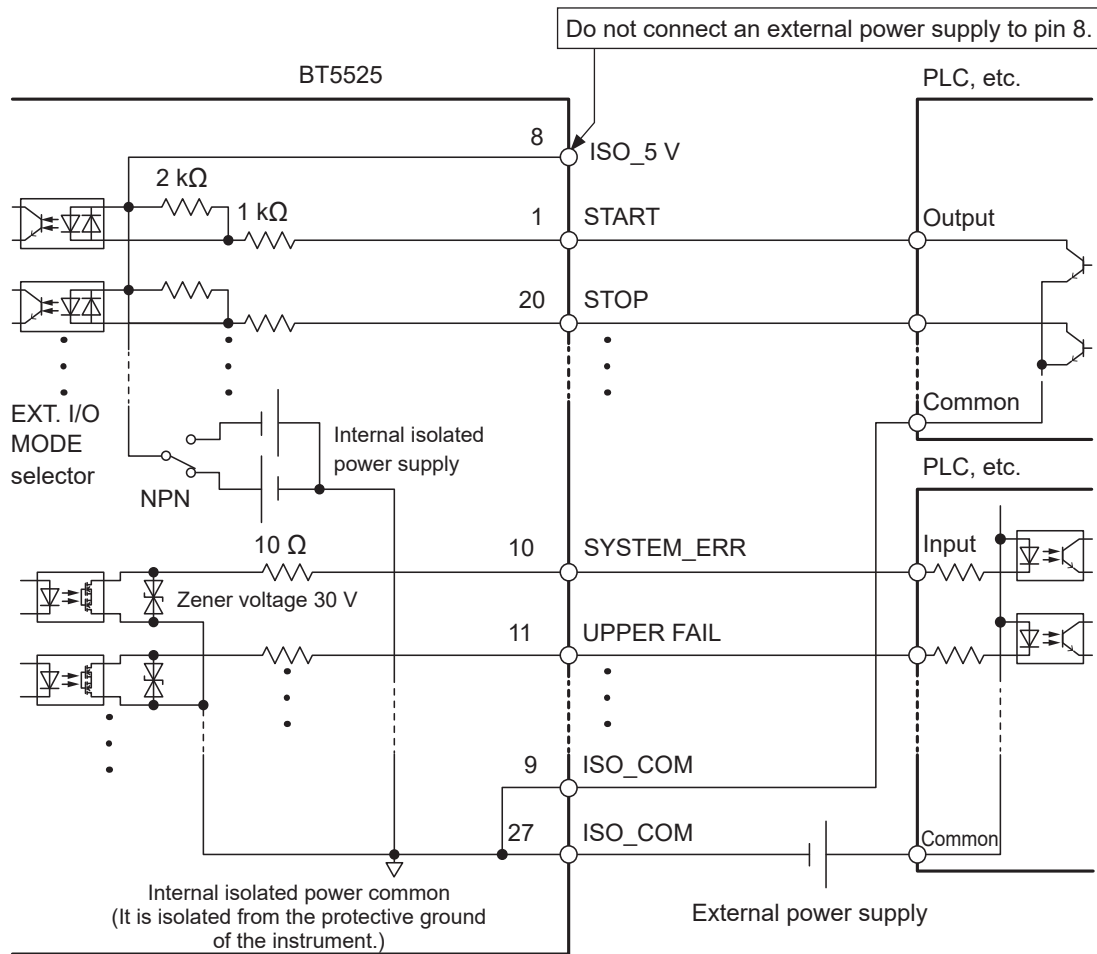

- Use ISO_COM for both input and output signals as a common terminal.
- If high current flows through the common wiring, branch off the common line for input and output signals around the ISO_COM terminal.
- When power is supplied from an external instrument, supply the power to the external power supply unit shown above.

PNP setting

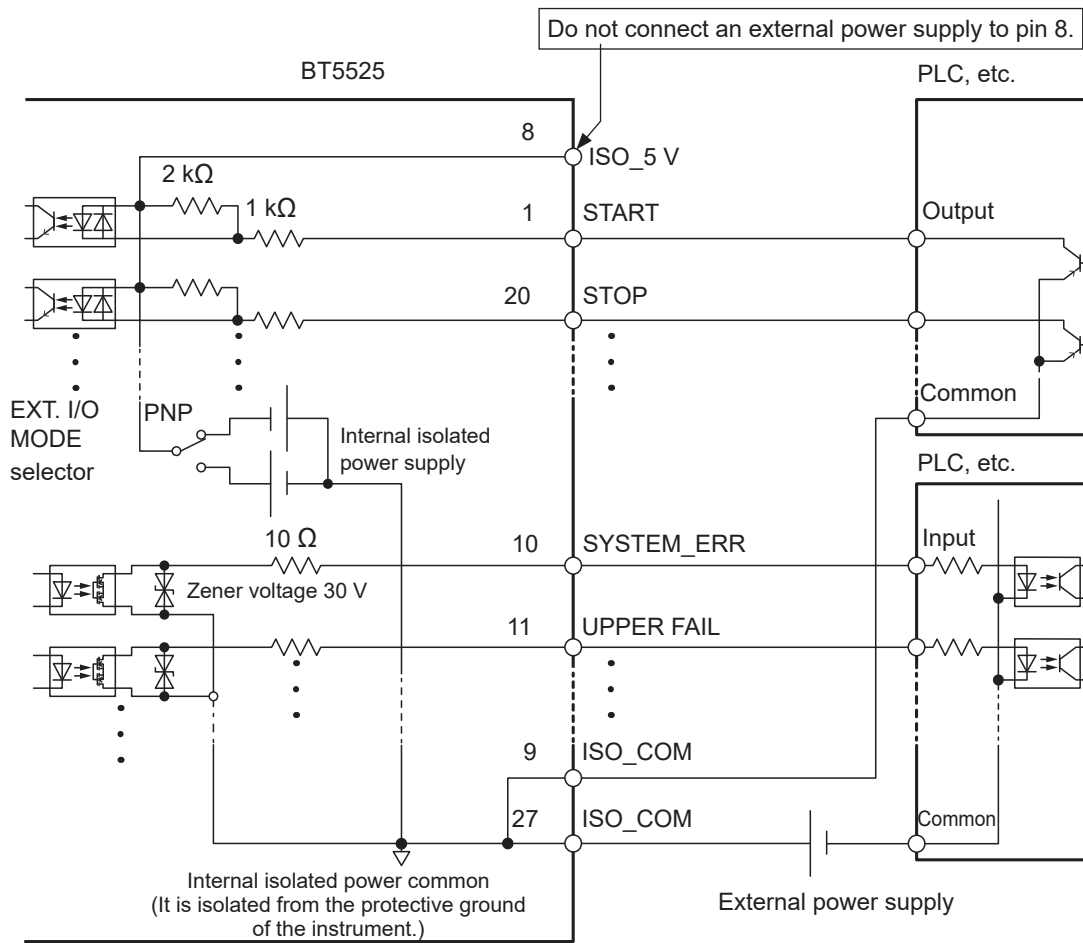

- Use ISO_COM for both input and output signals as a common terminal.
- When power is supplied from an external instrument, supply the power to the external power supply unit shown above.

Electrical specifications

See "EXT. I/O" (p. 187)

Connection examples

Input circuit connection example

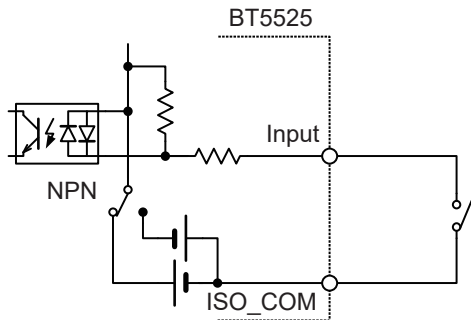

Connection with a switch

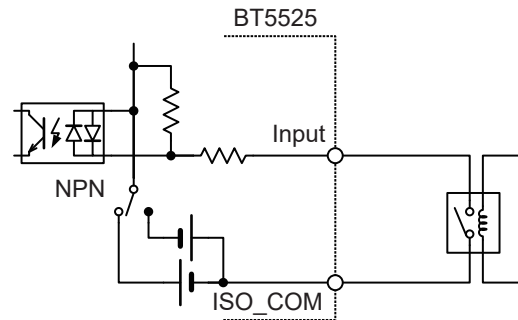

Connection with a relay

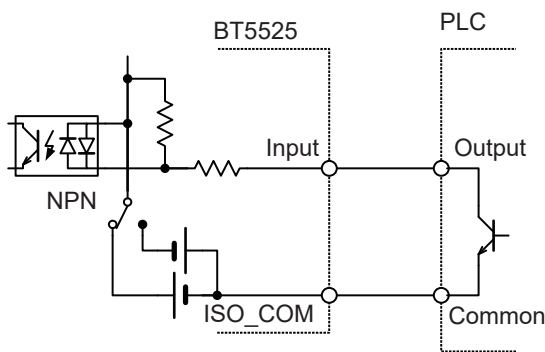

Connection with a PLC output (NPN)

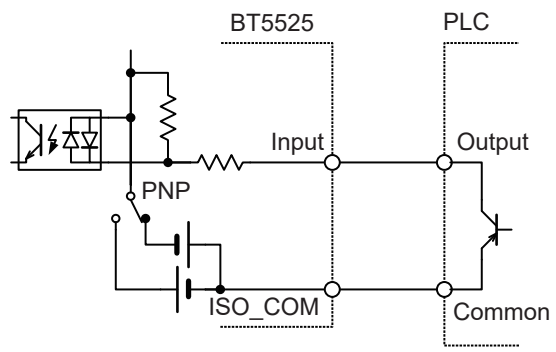

Connection with a PLC output (PNP)

Output circuit connection example

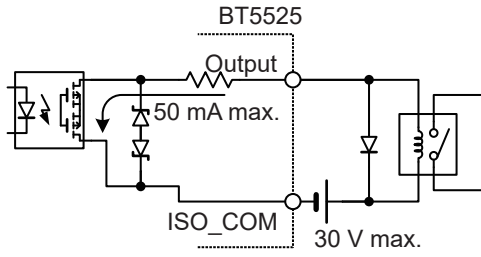

Connection with a relay

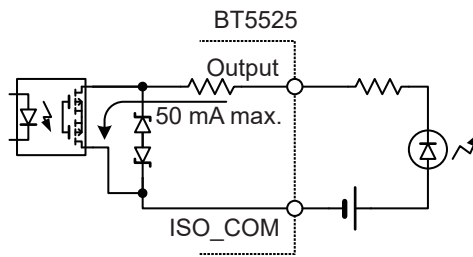

Connection with an LED

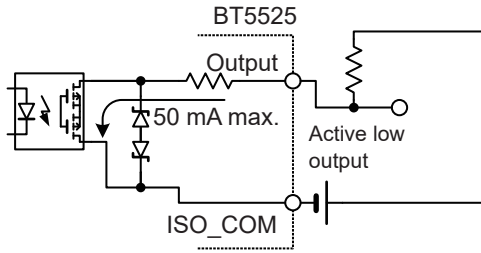

Active low output

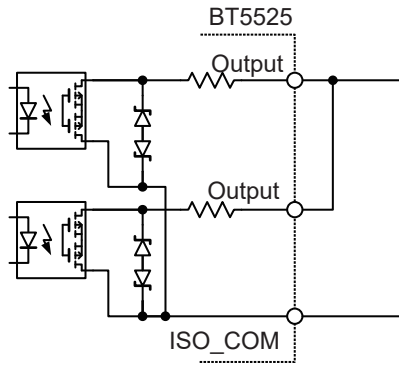

Wired OR

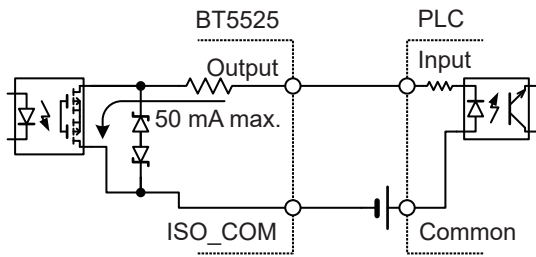

Connection with a PLC input
(positive common input)

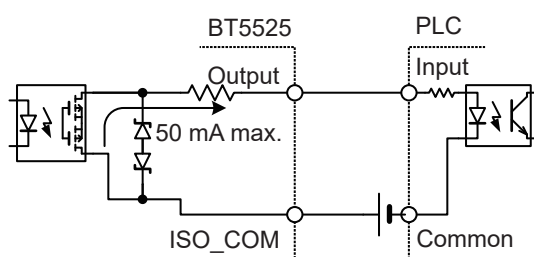

Connection with a PLC input
(negative common input)

7.4 Checking External Control

Input/output test (EXT. I/O test function)

The ON/OFF setting of output signals can be manually changed and the input signal status can be checked in the screen.

1 Open the Setting screen.

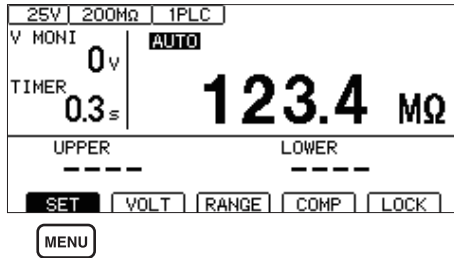

[MENU] [SET] Select

2 Select the [EXT I/O TEST].

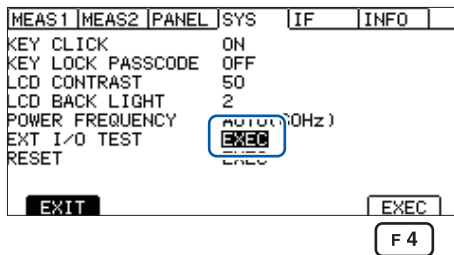

[Select] Select

[F 4] [EXEC] Execute

3 Execute an EXT. I/O test.

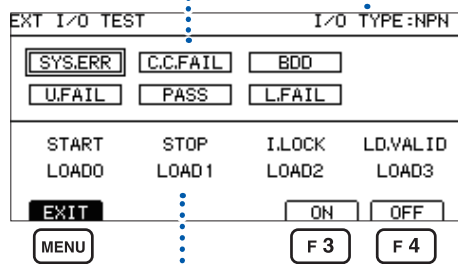

Output signal
Signals can be operated.

NPN/PNP Switch status

[Select] Select

[F 3] Turn ON the [ON] signal

[F 4] Turn OFF the [OFF] signal

[MENU] Return to the EXT. I/O setting screen

Input signal
The signal status is displayed.

IMPORTANT

- The TEST and VON signals cannot be manipulated using the EXT. I/O test function. To check signals, start an actual insulation resistance test.
- The LOAD0 to LOAD3 signals are finalized and displayed when the LOAD_VALID signal is input.

7 External Control (EXT. I/O)

7.5 Accessory Connector Assembly Procedure

This instrument is provided with an EXT. I/O connector, EXT. I/O connector cover, and so on. Assemble them according to the following procedure.

IMPORTANT

- Use a shielded cable for connecting a PLC (programmable logic controller), etc. to the EXT. I/O connector. Using any other type of cables can cause the system to malfunction due to noise.
- Connect the shield to the ISO_COM terminal of the EXT. I/O connector.
- If you lose or damage the provided screws, contact your authorized Hioki distributor or reseller.

Tools to be prepared

Screwdriver, shielded cable, soldering iron, accessories (A to H)

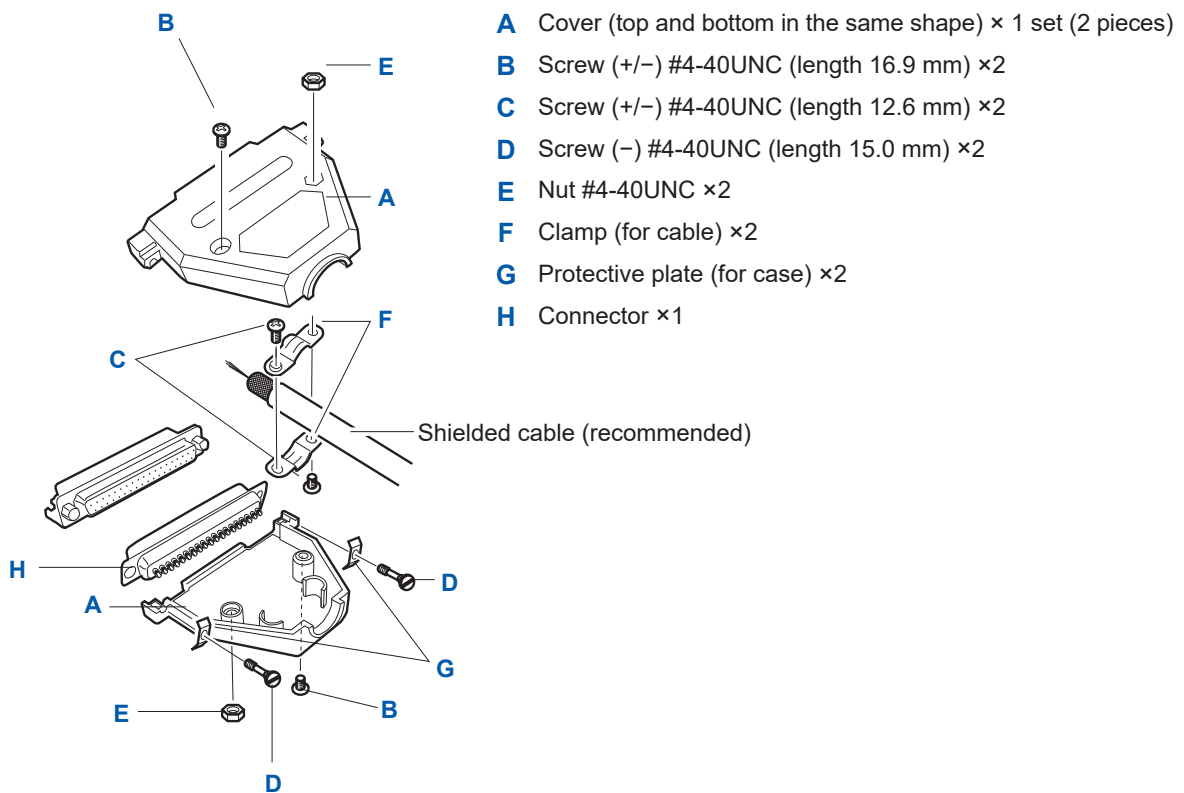

Assembly procedure

- 1** Solder the cable (shielded cable) to provided EXT. I/O connector (H).
- 2** Attach clamps (F) to the cable using screws (C).
- 3** Adjust clamps (F) so that they are located at the specified position of cover (A).
- 4** Attach screws (D) to protective plates (G).
- 5** Place connector (H), clamps (F), protective plates (G), and screws (D) on one side of cover (A).
- 6** Place the other side of cover (A) on top.
- 7** Secure cover (A) using screws (B) and nuts (E).

Excessively tightening the screws may damage the cover.

7.6 Using Analog Output

When analog output is used, a DC voltage that is proportional to the resistance is output from the analog output terminal on the back of the instrument.

Analog output is updated at the same time as the instrument displays the measured value. When the test is ended, the analog output is held with the final voltage output.

A voltage is output according to the resistance range as shown in the following table.

4 V is output when the maximum value of each resistance range is displayed.

For the procedure to set and check the resistance range, see “3.2 Setting the Range (Auto/Manual)” (p. 36).

Resistance Range	Resistance value range	Output voltage (DC)
2 MΩ	0.000 MΩ to 9.999 MΩ	0 V to 4 V
20 MΩ	0.00 MΩ to 99.99 MΩ	0 V to 4 V
200 MΩ	0.0 MΩ to 999.9 MΩ	0 V to 4 V
2000 MΩ (100 V ≤ V ≤ 500 V)	0 MΩ to 9999 MΩ	0 V to 4 V
Total resistance range	Over.F	4 V
	Under.F	0 V

IMPORTANT

When the resistance falls below the resistance display range, **[Under. F]** is displayed on the screen and 0 V is output from the analog output terminal.

See “Resistance measurement” (p. 180).

Connecting an output cord

When connecting an output cord to a recorder, etc., use one with an input resistance of 1 M Ω or more.

When the input resistance is low, accurate measurement cannot be performed.

Recommended cable: L9094 Output cord (option)

CAUTION

- Do not input any voltage or current to the analog output terminal.
-  ■ Do not connect the output cord plug to the measurement terminal of the instrument.
- Doing so may damage the instrument and output cord.

Connect the output cord plug to the analog output terminal on the back of the instrument.

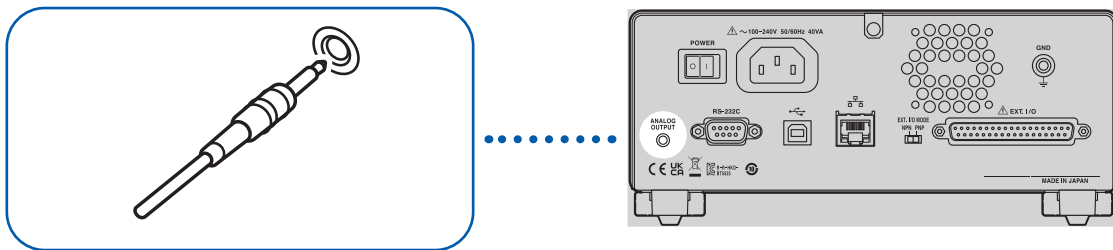

WARNING



- **Turn off all devices before connecting or disconnecting interface connectors.**

Failure to do so could cause the operator to experience an electric shock.

CAUTION



- **Do not unplug communications cables while the instrument is sending or receiving data.**

Doing so could damage the instrument or computer.

- **Do not short or input any voltage to the connector or output unit.**

Doing so could damage the instrument

- **Securely connect the connector.**

Otherwise, the instrument may be damaged or may not meet the specifications.

- **Use the same ground for the instrument and computer.**



When a communications cable is connected to the instrument with a potential difference between the ground circuits of the instrument and the PC, the instrument and PC may be damaged or malfunction.

- **Once the communications cable is connected, tighten the screws on the connector.**

Otherwise, data may not be transferred properly.

8.1 Interface Overview and Features

The instrument can be controlled using the RS-232C interface, LAN interface, or USB interface. It is not necessary to set which interface to use. However, use a single interface to control the instrument to avoid malfunction.

For the specifications, see “Interface specifications” (p. 186).

After the power is turned on, the Measurement screen is displayed. Wait for approximately 3 seconds to send a communications command.

For communications command and query notations, see “8.9 Communications Command Reference” (p. 130).

Remote state and local state

The instrument is in the remote state during communications and **[RMT]** is displayed on the Measurement screen. Any operation keys except for the **MENU** key and **STOP** key become disabled.

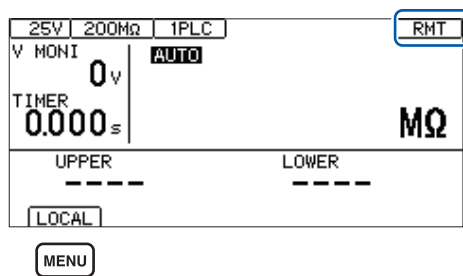

[LOCAL]

Cancels the remote state and returns to the local state.



Stops measurement.

Pressing the **MENU** key cancels the remote state and enables the key operations.

8.2 RS-232C Interface

The instrument can be controlled using the RS-232C interface. Set the same communications speed for the controller and the instrument.

Setting communications conditions

1 Open the Setting screen.

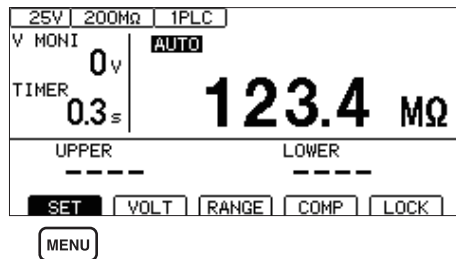

[MENU] **[SET]** Select

2 Select the communications speed using **[RS-232C SPEED]**.

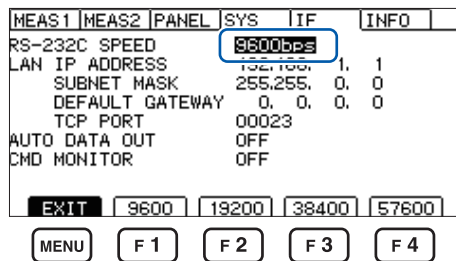

[SELECT] Select

[F 1] **[9600]** (bps)

[F 2] **[19200]** (bps)

[F 3] **[38400]** (bps)

[F 4] **[57600]** (bps)

[MENU] **[EXIT]** Return to the Measurement screen

Some of the communications speeds may not be used depending on the PC due to a greater error. If that is the case, select a lower speed setting.

Controller (PC, PLC, etc.) settings

Be sure to set the controller as follows.

- Start/stop synchronization
- Communications speed: 9600 bps / 19200 bps / 38400 bps / 57600 bps (According to the instrument setting)
- Stop bit: 1
- Data length: 8
- Parity check: None
- Flow control: None

Connecting the RS-232C cable

Connect the RS-232C cable to the RS-232C connector. Be sure to tighten the screws when connecting the cable.

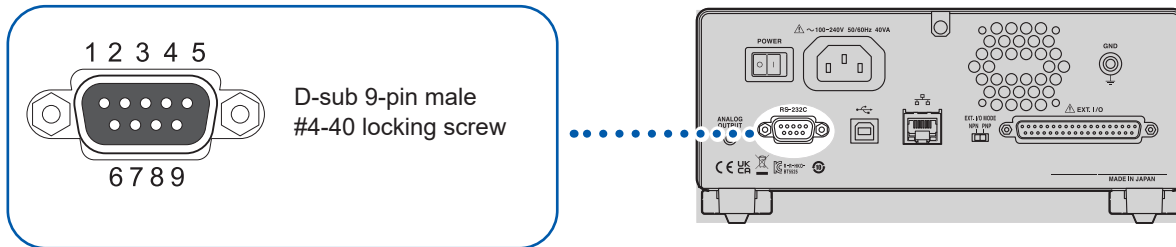

When connecting the RS-232C cable to the controller (DTE), prepare a cross cable compatible with the instrument's connector and controller's connector.

The input and output connectors use the terminal (DTE) specifications.

Pin Nos. 2, 3, and 5 are used for this instrument. Other pins are not to be used.

Pin No.	Signal name			Signal	Remarks
	Common	EIA	JIS		
1	DCD	CF	CD	Carrier detect	Not used
2	RxD	BB	RD	Receive data	
3	TxD	BA	SD	Send data	
4	DTR	CD	ER	Data terminal ready	ON level (+5 V to +9 V) fixed
5	GND	AB	SG	Signal ground	
6	DSR	CC	DR	Data set ready	Not used
7	RTS	CA	RS	Request to send	ON level (+5 V to +9 V) fixed
8	CTS	CB	CS	Clear to send	Not used
9	RI	CE	CI	Ring indicator	Not used

When connecting the instrument and a computer

Use a cross cable with D-sub 9-pin female and D-sub 9-pin female.

Recommended cable: Hioki L9637 RS-232C Cable (3 m)

See "L9637 RS-232C Cable" (p. 192).

8.3 LAN Interface

The instrument is equipped with Ethernet 100BASE-TX as an interface. Connect to the network using a LAN cable compatible with 10BASE-T or 100BASE-TX to control the instrument using a computer, etc.

Connecting the instrument and PCs on the network

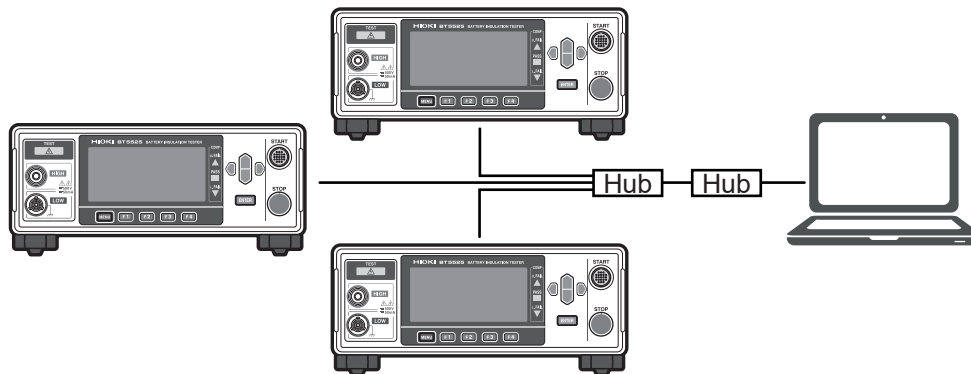

Assign each instrument a different IP address.

Connecting one instrument and one PC

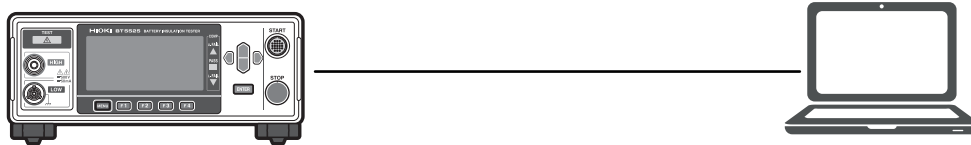

Create a program and connect to the communications command port with the TCP to control the instrument using communications commands.

Preparation procedure

1 Setting the communications conditions of the instrument

p. 106



2 Connecting a LAN cable

p. 109

Settings for the communications conditions

Items to be checked before setting the communications conditions

The settings for the instrument and external devices are different when connecting to an existing network or establishing a new network for the instrument and one computer.

Connecting the instrument to an existing network

You must first ask the network system administrator (department) to allocate the following setting in advance. Ensure that the instrument uses a unique address that is not being used by any other device on the network.

- Instrument address settings
 - IP address: ____:____:____:____
 - Subnet mask: ____:____:____:____
- Gateway
 - Whether or not to use a gateway: Used/Not used
 - IP address (if used): ____:____:____:____
(If not used, set 0.0.0.0)
- Communications command port number to be used for communications commands: (Default setting: 23)

Establishing a new network for the instrument and one computer

(Use a local network that is not connected externally.)

The following settings are recommended if there is no administrator or communications condition setting is entrusted to you.

Setting example

IP address	Set the serial numbers as follows.
Computer:	192.168.0.1
Instrument first unit:	192.168.0.2
Instrument second unit:	192.168.0.3
Instrument third unit:	192.168.0.4
	↓
Subnet mask:	255.255.255.0
Gateway:	OFF
Communications command port number:	23

Setting items

IP address	The IP address is used to identify individual devices that are connected to the network. Ensure that the instrument uses a unique address that is not being used by any other device on the network.
Subnet mask	The subnet mask is used to separate the IP address into the portion that indicates the network and the portion that indicates the device. Set the subnet mask in the same manner as for the subnet masks of the other instruments in the same network.
Default gateway IP address	<p>For network connection Sets the default network IP address if the computer to be used (instrument for communications) is in a different network from the network to which the instrument is connected. If the computer is in the same network, specify the same settings as for the default gateway IP address in the computer settings.</p> <p>One instrument and one computer connection, gateway not used Set the default gateway IP address to 0.0.0.0.</p>
Communications command port number	Sets the TCP/IP port number to be used for connection.

Setting the communications conditions

1 Open the Setting screen.

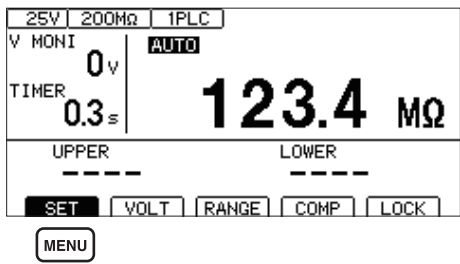

MENU [SET] Select

2 Set [LAN IP ADDRESS] to the edit mode.

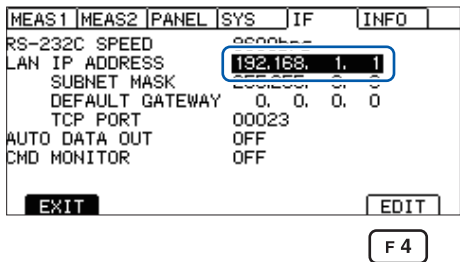

Select

F4 [EDIT] Edit

3 Set the IP address.

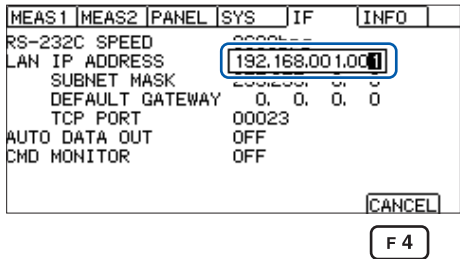

Select

ENTER Confirm

F4 [CANCEL] Cancel

4 Set [SUBNET MASK] to the edit mode.

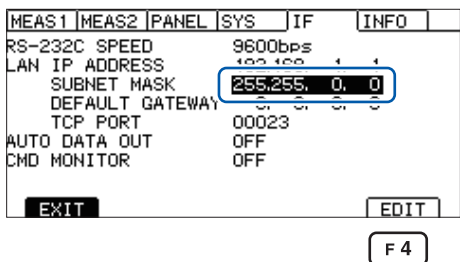

Select

F4 [EDIT] Edit

5 Set the subnet mask.

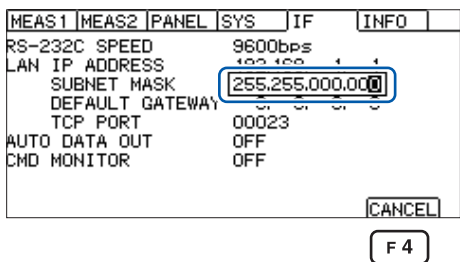

Select

ENTER Confirm

F4 [CANCEL] Cancel

6 Set [DEFAULT GATEWAY] to the edit mode.

MEAS1	MEAS2	PANEL	SYS	IF	INFO
RS-232C	SPEED		9600bps		
LAN	IP ADDRESS		192.168.	1.	1
	SUBNET MASK		255.255.	0.	0
	DEFAULT GATEWAY		0.	0.	0
	TCP PORT		00000		
	AUTO DATA OUT		OFF		
	CMD MONITOR		OFF		
EXIT			OFF	EDIT	

F 4

 Select

 [EDIT] Edit

7 Set the default gateway.

MEAS1	MEAS2	PANEL	SYS	IF	INFO
RS-232C	SPEED		9600bps		
LAN	IP ADDRESS		192.168.	1.	1
	SUBNET MASK		255.255.	0.	0
	DEFAULT GATEWAY		000.000.000.000		
	TCP PORT		00000		
	AUTO DATA OUT		OFF		
	CMD MONITOR		OFF		
				CANCEL	

F 4

 Select

 Confirm

 [CANCEL] Cancel

8 Set [TCP PORT] to the edit mode.

MEAS1	MEAS2	PANEL	SYS	IF	INFO
RS-232C	SPEED		9600bps		
LAN	IP ADDRESS		192.168.	1.	1
	SUBNET MASK		255.255.	0.	0
	DEFAULT GATEWAY		0.	0.	0
	TCP PORT		00023		
	AUTO DATA OUT		OFF		
	CMD MONITOR		OFF		
EXIT				EDIT	

F 4

 Select

 [EDIT] Edit

9 Set the communications command port.

MEAS1	MEAS2	PANEL	SYS	IF	INFO
RS-232C	SPEED		9600bps		
LAN	IP ADDRESS		192.168.	1.	1
	SUBNET MASK		255.255.	0.	0
	DEFAULT GATEWAY		0.	0.	0
	TCP PORT		00023		
	AUTO DATA OUT		OFF		
	CMD MONITOR		OFF		
				CANCEL	

F 4

 Select

 Confirm

 [CANCEL] Cancel

Setting the LAN communications

When configuring the LAN communications settings using communications commands, use the following commands.

Comma delimiters are used to separate IP address and subnet mask values.

Command	Reference
<code>:SYSTem:COMMunicate:LAN:IPADdress <Number 1>,<Number 2>,<Number 3>,<Number 4></code> Sets the IP address of the instrument.	p. 162
<code>:SYSTem:COMMunicate:LAN:SMASk <Number 1>,<Number 2>,<Number 3>,<Number 4></code> Sets the subnet mask of LAN.	p. 163
<code>:SYSTem:COMMunicate:LAN:GATeway <Number 1>,<Number 2>,<Number 3>,<Number 4></code> Sets the IP address of the default gateway.	p. 164
<code>:SYSTem:COMMunicate:LAN:CONTRol <Port number></code> Sets the port number of communications commands.	p. 165
<code>:SYSTem:COMMunicate:LAN:UPDate</code> Updates the LAN settings.	p. 166

Enhancing the speed of LAN communications

The TCP/IP communications used for LAN communications of the instrument helps process the large volumes of data to be sent more efficiently. When small data, such as a command that controls the instrument, is sent, data transmission does not take place until the data to be sent reaches a certain volume, which makes the response from the instrument slower. In order to enhance the communications speed, disable the transmission delay (Nagle algorithm) in the control program.

For Visual Basic®, Visual C#®, Visual C++®/CLI (.NET Framework)

Set the NoDelay property of the TcpClient class to "true".

For Visual C®/C++® Microsoft Foundation Class, Visual Basic® for Applications

Set TCP_NODELAY of the socket option to 1.

When using other programming languages, refer to the applicable document.

Connecting a LAN cable

Connect a LAN cable to the LAN connector on the back of the instrument.

! CAUTION

- If routing a LAN cable outdoors or over more than 30 m, attach a LAN surge protector or other suitable protective device.



Failure to do so could cause damage to the instrument due to increased susceptibility to the effects of induced lightning.

Recommended cable: 100BASE-TX or 10BASE-T compatible LAN cable (Both straight and cross cables can be used.)

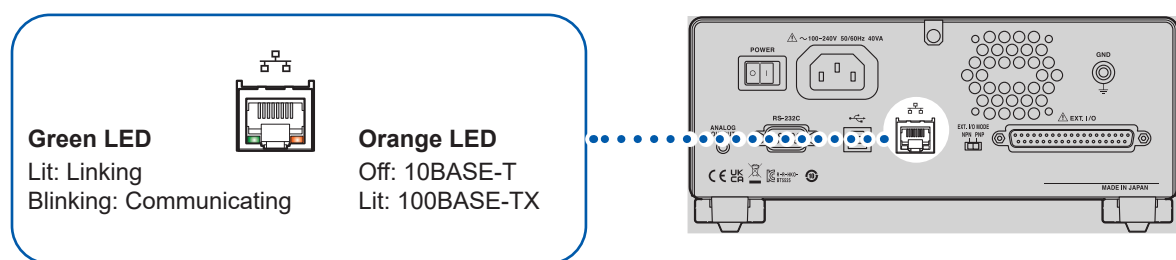

If the green indicator does not light up even when the LAN is connected, the instrument or connected instruments may be damaged or the LAN cable may be broken.

8.4 USB Interface

Installing the USB driver

When the instrument is connected to a computer, the USB driver is automatically installed. Since the OS standard driver is installed, it is not necessary to install another driver.

Installation procedure

- 1** Log into the computer as an administrator.
- 2** Connect the instrument and computer using a USB cable.

The USB driver is automatically installed.

After the installation is completed, the instrument is recognized.

- For Windows 10 or Windows11, **[USB Serial Port (COMx)]** is displayed at the device manager port (COM and LPT) when the USB is properly recognized. The COM number varies depending on the environment.
- Even if an instrument with a different serial number is connected, there may be a notification that a new device has been detected.

Connecting the USB cable

Connect a USB cable type AB (commercially available) to the USB connector of the instrument.

CAUTION



- Do not unplug the USB cable while communications are ongoing.

Doing so could damage the instrument or computer.

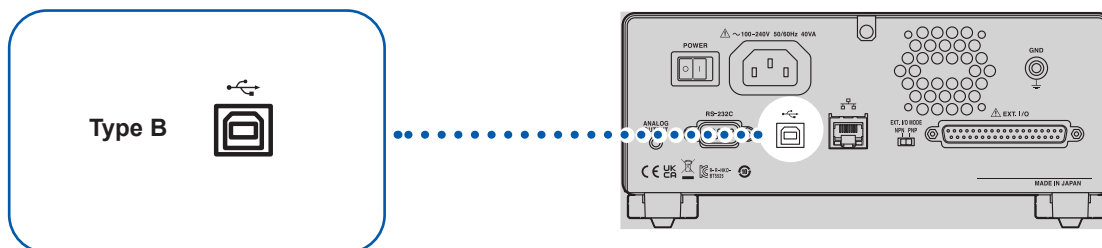

8.5 Automatically Sending the Measured Value Every Time a Test Is Completed (Auto Data Output Function)

After the test is complete, the measured value can be automatically sent to an external device via the instrument's communications interface.

IMPORTANT

When using the auto data output function, do not send a command to the instrument until the measured value is received after the test starts. The measured value may be sent in duplicate.

1 Open the Setting screen.

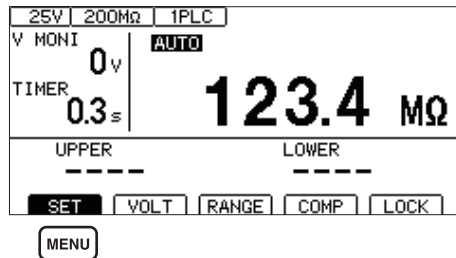

MENU [SET] Select

2 Set the interface to which data is automatically output by [AUTO DATA OUT].

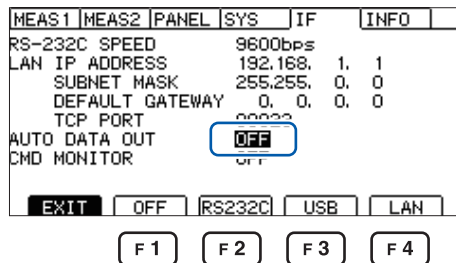

Select

F1 [OFF] (Not sending automatically)

F2 [RS232C]

F3 [USB]

F4 [LAN]

3 Select the data type.

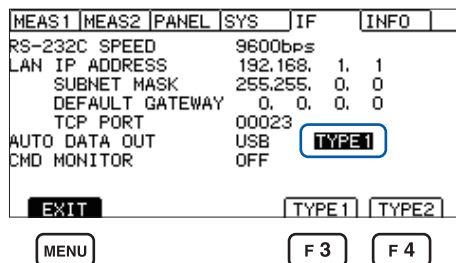

Select

F3 [TYPE1] Sends automatically in the format of type 1

F4 [TYPE2] Sends automatically in the format of type 2

MENU [EXIT] Return to the Measurement screen

See "Communications settings" (p. 167) ":SYSTEM:COMMunicate:DATAout command".

8.6 Communications Command Display (Command Monitor Function)

Using the command monitor function for creating a program is useful as it displays the command and response on the Measurement screen. The command monitor function allows communications commands and query responses to be displayed on the screen.

1 Open the Setting screen.

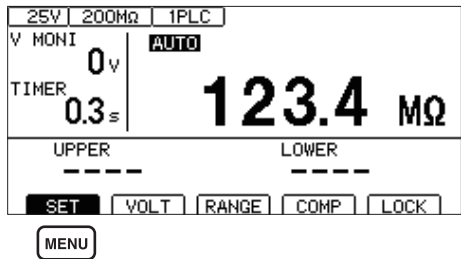

MENU **[SET]** Select

2 Set **[CMD MONITOR]** to **[ON]**.

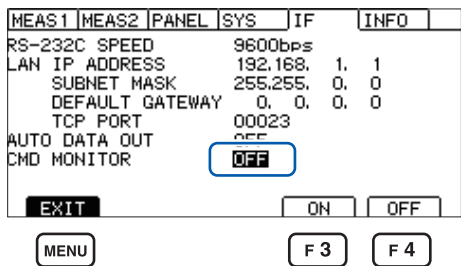

Left Arrow **Right Arrow** Select

F 3 **[ON]**

F 4 **[OFF]**

MENU **[EXIT]** Return to the Measurement screen

The communications command that has been sent and received is displayed on the Measurement screen.

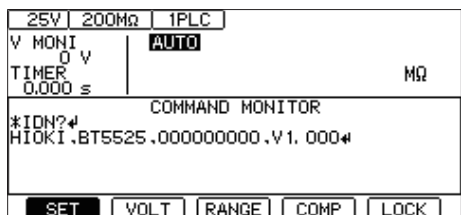

Messages displayed on the command monitor and their meanings

The following messages are displayed if an error occurs when a command is executed.

Command error (incorrect command, argument format, etc.)

```
#CMD ERROR
```

Invalid argument range

```
#PARAM ERROR
```

Execution error

```
#EXE ERROR
```

The approximate position where an error occurs is also displayed.

Incorrect argument (1E-3 is outside the range.)

```
:TIMer 1E-3
#      ^  PARAM ERROR
```

Incorrect notation (:SPED 10 instead of :SPEED 10)

```
:SPED 10
#^  CMD ERROR
```

IMPORTANT

When an invalid character code is received, the code is enclosed in "<>" and displayed as a hexadecimal character/number.

For instance, 0xFF is displayed as <FF> and 0x00 as <00>.

When only a hexadecimal character/number is displayed, check the communications conditions or lower the communications speed.

When an RS-232C error occurs, the following is displayed.

Overrun error (reception failure) **#RS: Overrun Error**

When a break signal is received **#RS: Break Error**

When a parity error occurs **#RS: Parity Error**

When a framing error occurs **#RS: Framing Error**

When these characters are displayed, check the communications conditions or lower the communications speed.

The error position may shift when commands are consecutively received.

8.7 Communications Method

Various communications commands are available to control the instrument using an interface. The communications commands include program messages sent from a computer to the instrument and response messages sent from the instrument to the computer.

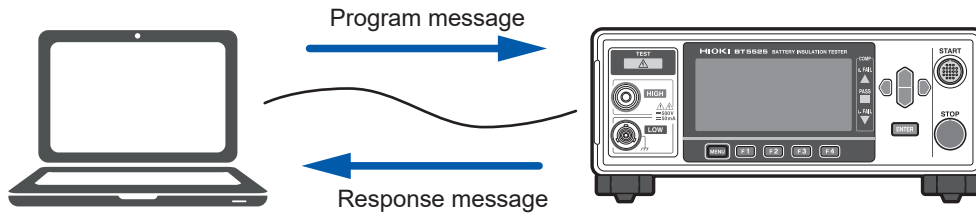

Communications commands are categorized as follows.

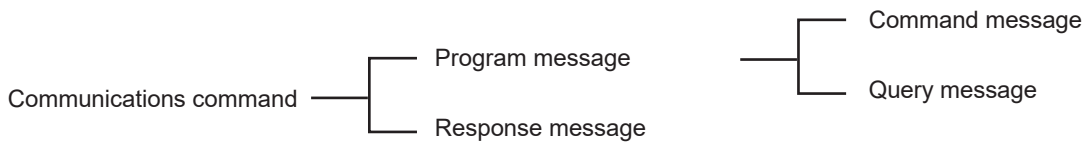

Message format

Program message

The program messages can be divided into command messages and query messages.

(1) Command message

A command message is used to control the instrument, for example, when setting and resetting it.

Example: Command to set the test voltage

:VOLTage 100

↑
↑
↑
 Header Space Data

(2) Query message

A query message is used to query operation results, measurement results, and settings of the instrument.

Example: Command to query the current test voltage

:VOLTage?

↑
↑
 Header Question mark

See “Header” (p. 115), “Separator” (p. 116), and “Data” (p. 117).

Response message

A response message is created when the instrument receives a query message and checks the syntax.

If an error occurs when a query message is received, no response message is generated for that query.

Command syntax

This command has the following two formats.

- Long form that can easily be associated with functions
- Short form that is more compact

This manual indicates the short form in uppercase letters and the remaining long form in lowercase letters. The instrument recognizes the commands indicated in either type of letters.

<code>:SYSTem:COMMunicate:LAN:IPADdress</code>	Notation in this manual
<code>:SYSTEM:COMMUNICATE:LAN:IPADDRESS</code>	OK (long form)
<code>:SYST:COMM:LAN:IPAD</code>	OK (short form)
<code>:SYST:COMM:LAN:IPADD</code>	Error
<code>:SYST:COMM:LAN:IPA</code>	Error

The long form in uppercase letters is used for response messages from the instrument.

Header

Program messages require a header.

(1) Command program header

There are three types.

Command type	Example	Description
Simple command type header	<code>:VOLTage</code>	Header consisting of a word starting with an alphabetical character
Compound command type header	<code>:SYSTem:COMMunicate:LAN:IPADdress</code>	Header consisting of multiple headers of the simple command type separated by colons (:)
Standard command type header	<code>*RST</code>	Header starting with an asterisk (*) indicating that it is a standard command defined by IEEE 488.2

(2) Query program header

This header is used to query the settings of the instrument and measured values.

As shown in the following examples, it is recognized as a query when a question mark (?) is added after a program header.

Example:	<code>*STB?</code>
	<code>:SYSTem:ERRor?</code>

Data

The instrument uses the character data and the decimal numeric data as the data depending on the commands.

(1) Character data

The character data always starts with an alphabetical character and consists of alphabetical and numerical characters. The character data accepts uppercase and lowercase letters and always returns a response in uppercase letters from the instrument.

The long form and short form are available and both can be recognized just like the command syntax.

Example: :COMParator:MODE CONTInue

(2) Decimal numeric data

Three formats are used for numeric data: NR1, NR2, and NR3. The instrument recognizes the data of both signed and unsigned numerical values. The data of unsigned numerical values are handled as positive numerical values.

Numerical values are rounded to a decimal place that can be accepted by the instrument.

- NR1 integer data (Example: +12, -23, 34)
- NR2 decimal data (Example: +1.23, -23.45, 3.456)
- NR3 floating-point exponential representation data (Example: +1.0E-2, -2.3E+4)

The format consisting of all three types above is called the “NRf format”.

The instrument recognizes numeric data in the NRf format.

The response data is sent in the format specified for each command.

Example: :VOLTAge 100
 :TIMer 1.5

Compound command header omission

If several commands having a common header are combined to form a compound command, the common portion can be omitted after its initial occurrence when the commands are written together in sequence.

This common portion is called the “current path” and subsequent commands are analyzed presuming that the current path is omitted until this current path is cleared.

The usage of the current path is shown in the following example.

<p>Full expression</p> <pre><code>:SYSTem:COMMunicate:LAN:IPADdress 192,168,1,1;:SYSTem:COMMunicate :LAN:SMASk 255,255,255,0</code></pre>
<p>Compacted expression</p> <pre><code>:SYSTem:COMMunicate:LAN:IPADdress 192,168,1,1;SMASk 255,255,255,0</code></pre> <p>↑ The portion becomes the current path and can be omitted in the next command.</p>

The current path is cleared in the following cases.

- When the instrument is turned on
- When a command with a colon (:) at the start of the command is sent
- When a message terminator is detected

Messages of the standard command type can be executed regardless of the current path. They have no effect upon the current path.

A colon (:) is not required at the start of the simple and compound command type headers. However, to avoid confusion with abbreviated forms and malfunction of the instrument, we recommend placing a colon (:) at the start of a command.

Output queue and input buffer

Output queue

Response messages are stored in the output queue. The output queue is cleared in the following cases.

- When data is loaded using a controller
- When the instrument is turned on
- When a query error occurs

The instrument output queue can buffer at least 64 B of response messages.

When there is no more buffer space, the query operation is deferred until a response message is received.

Input buffer

The input buffer can buffer at least 1 KB of communications commands.

When there is no more buffer space, the operation is stopped until space becomes available.

Status system

The status system of the instrument is designed based on the status model defined by IEEE 488.2.

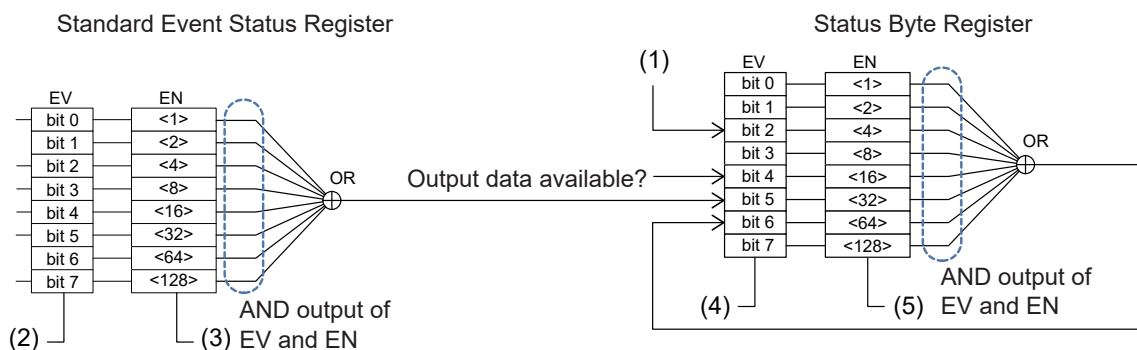

(1)	:SYSTem:ERRor?	The value "1" will be set when an error occurs.
(2)	*ESR?	When "1" is set for each bit, the status is retained until the result is returned after the query is received. When the *ESR? query is returned, each bit is cleared. When *CLS is executed, each bit is cleared.
(3)	*ESE *ESE?	Masks bits reporting the status of the Standard Event Status Register to the Status Byte Register.
(4)	*STB?*	The status at the point when *STB? is received is returned. Even though the *STB? query result is returned, each bit is not cleared. (To clear the bits, the query for each event register should be executed to clear each cause or *CLS should be executed.)
(5)	*SRE *SRE?	Masks bits reporting the status of the Status Byte Register to the Status Byte Register's MSS bit (bit 6). See "Status Byte Register (STB)" (p. 120)

Status Byte Register (STB)

The Status Byte Register (STB) is an 8-bit register in which information for the event register and output queue is set.

The Status Byte Register (STB) is not cleared even if the ***STB?** query is executed. It is cleared when the ***CLS** command is executed, however, the ERR bit is not cleared when there is an instrument error.

Bit 7	–	Unused
Bit 6	SRQ	Unused
	MSS	This represents the logical sum of the other bits of the Status Byte Register (STB).
Bit 5	ESB	Standard event summary (logical sum) bit This is the logical sum of the Standard Event Status Register. It is cleared with the *ESR? command.
Bit 4	MAV	Message available It is set to “1” when a message is present in the output queue.
Bit 3	–	Unused
Bit 2	ERR	Error bit It is set to “1” when there is error information. It is cleared when error information is output with the :SYSTEM:ERROR? command. However, the bit is not cleared in the event of a hardware error.
Bit 1	–	Unused
Bit 0	–	Unused

Service Request Enable Register (SRER)

When each bit of the Service Request Enable Register (SRER) is set to “1”, the MSS bit is set to “1” if any corresponding bit of the Status Byte Register (STB) changes from “0” to “1” and the MSS bit is set to “0” when all the bits become “0”.

Any unused bits and bit 6 of the Status Byte Register (STB) are fixed as 0.

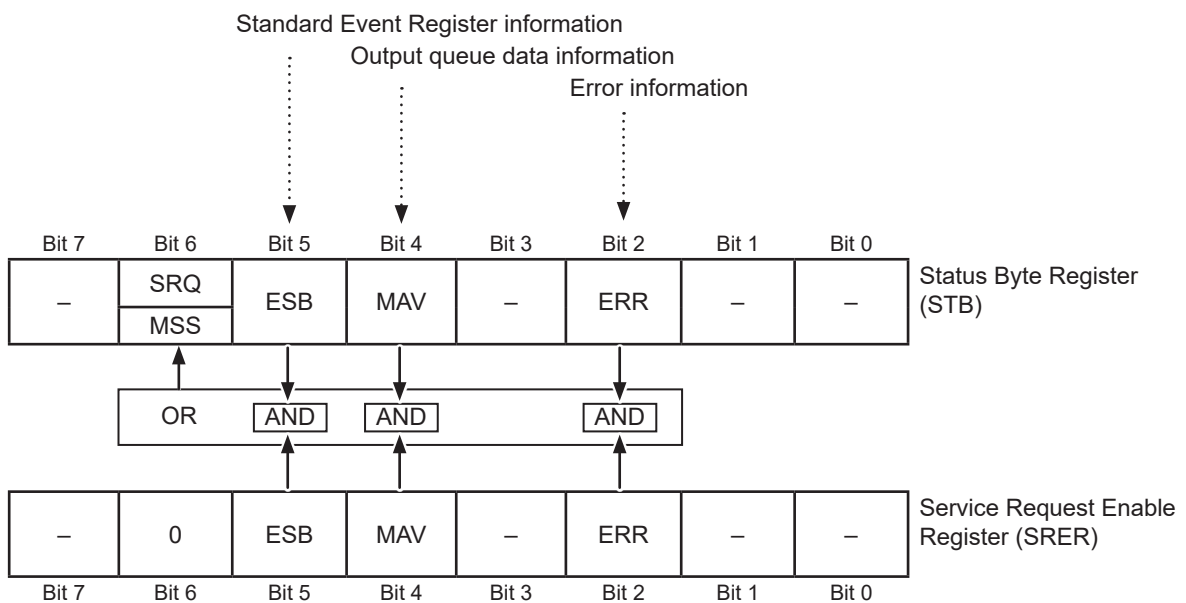

Standard Event Status Register

Standard Event Status Register (SESR)

The Standard Event Status Register (SESR) is an 8-bit register.

The contents of the Standard Event Status Register (SESR) are cleared in the following cases.

- When the ***CLS** command is executed
- When an event register query is executed (***ESR?**)
- When the instrument is turned on again

Bit 7	PON	Power-On Flag This flag is set to “1” when the instrument is turned on or upon recovery from an outage.
Bit 6	(URQ)	This bit is not used for the instrument. (User Request)
Bit 5	CME	Command Error (The command to the message terminator is ignored.) This bit is set to “1” when a received command contains a syntax or semantic error. <ul style="list-style-type: none"> • When a program header error is detected • Incorrect number of data parameters • Invalid parameter format • When a command not supported by the instrument is received
Bit 4	EXE	Execution Error This bit is set to “1” when a received command cannot be executed for some reason. <ul style="list-style-type: none"> • The specified data value is outside of the set range. • When the specified data cannot be set • Execution is prevented by another operation being performed.
Bit 3	DDE	Device-Dependent Error This bit is set to “1” when a device-dependent error occurs. For details about the error, see “Before requesting repair” (p. 195).
Bit 2	QYE	Query Error (The output queue is cleared.) This bit is set to “1” when an error is detected during an output queue related process. <ul style="list-style-type: none"> • When the data overflows the output queue. • When the data in the output queue is lost
Bit 1	(RQC)	This bit is not used for the instrument. (Control Request)
Bit 0	OPC	Operation Complete This bit is set to “1” when the operation is completed. <ul style="list-style-type: none"> • When the *OPC command is executed • When the operation of all messages up to the *OPC command is completed

Standard Event Status Enable Register (SESER)

When each bit of the Standard Event Status Enable Register (SESER) is set to “1”, the ESB bit of the Status Byte Register (STB) is set to “1” if any corresponding bit of the Standard Event Status Register (SESR) changes from “0” to “1” and the ESB bit is set to “0” when all the bits become “0”.

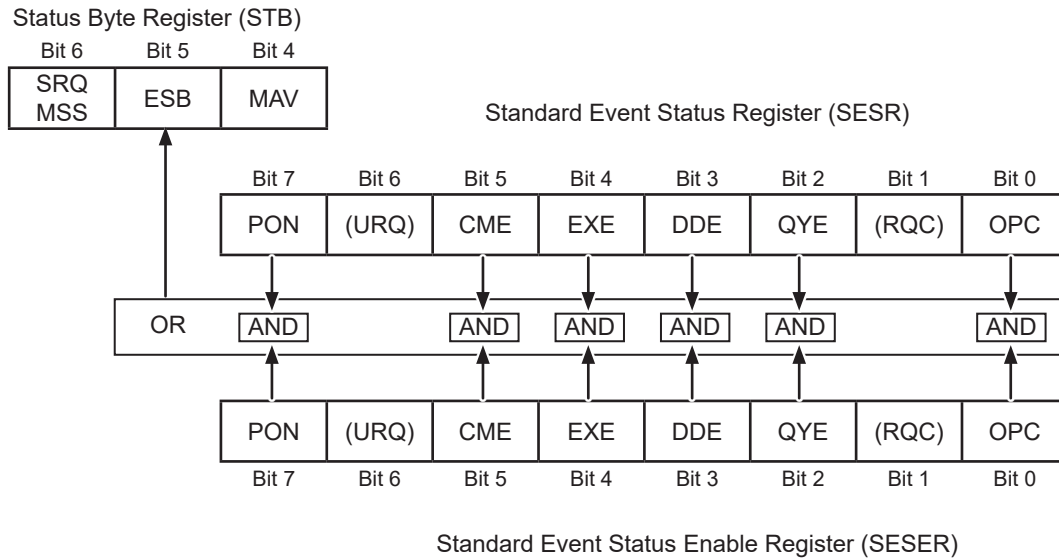

Queries and settings for registers

Register	Query	Settings
Status Byte Register	*STB?	–
Service Request Enable Register	*SRE?	*SRE
Standard Event Status Register	*ESR?	–
Standard Event Status Enable Register	*ESE?	*ESE

Items restored to the default settings

The following items are restored to the default settings when the instrument is initialized.
For the initialization of the device specific functions, see “11.9 Default Setting” (p. 214).

✓: Restored, –: Not restored

Register	When the instrument is turned on	*RST command	*CLS command
Device specific functions (measurement conditions, etc.)	–	✓	–
Output queue	✓	–	–
Input buffer	✓	–	–
Status Byte Register	✓	–	✓ ^{*1}
Event Register	✓ ^{*2}	–	✓
Enable Register	✓	–	–
Current path	✓	–	–

*1: Clears bits other than the MAV bit.

*2: Excludes the PON bit (bit 7).

8.8 Communications Command List

Category	Communications command	Functions	Reference
Standard command	*IDN?	Querying the instrument ID (Identification Code)	p. 131
	*RST	Changing the settings to the default settings (except for the communications settings)	p. 131
	*TST?	Executing a self-test	p. 131
	*OPC	Waiting for the current operation to complete and setting the operation completion bit of the Standard Event Status Register (SESR) to 1	p. 132
	*OPC?	Waiting for the current operation to complete and returning 1	
	*WAI	Waiting for the current operation to complete	p. 132
Event Register	*CLS	Clearing the Event Status Register	p. 133
	*ESE <Mask>	Setting the Standard Event Status Enable Register (SESER)	p. 133
	*ESE?	Querying the Standard Event Status Enable Register (SESER)	
	*ESR?	Querying the Standard Event Status Register (SESR)	p. 133
	*SRE <Mask>	Setting the Service Request Enable Register (SRER)	p. 134
	*SRE?	Querying the Service Request Enable Register (SRER)	
	*STB?	Querying the Status Byte Register (STB)	p. 134
Error	:SYSTem:ERRor?	Reading and clearing errors	p. 135
Measurement control	:START	Starting the test	p. 135
	:STOP	Ending the test	p. 135
	:STATe?	Querying the measurement status	p. 136
Measurement command	:MEASure:VALid <Response details>	Setting the response details of measured values	p. 136
	:MEASure:VALid?	Querying the response details of measured values	
	:MEASure:FORMat:OVER {TYPE1 TYPE2}	Setting the over-range value response type	p. 137
	:MEASure:FORMat:OVER?	Querying the over-range value response type	
Measured value output	:MEASure?	Querying the measured value	p. 137
	:MEASure:MONItor?	Querying the voltage monitor value	p. 139
	:MEASure:CLEar	Clearing the measured value	p. 139
	:MEASure:COUNt?	Querying the number of measured values saved in the memory	p. 139
	:MEASure:MEMory? [CRLF]	Querying the measured values saved in the memory	p. 139

Category	Communications command	Functions	Reference
Measurement settings	:VOLTage <Test voltage>	Setting the test voltage	p. 140
	:VOLTage?	Querying the test voltage	
	:RANGe <Resistance range>	Setting the resistance range	p. 140
	:RANGe?	Querying the resistance range	
	:RANGe:AUTO {ON OFF}	Setting the auto range	p. 141
	:RANGe:AUTO?	Querying the auto range	
	:SPEed <Sampling time>	Setting the sampling time (measurement speed)	p. 141
	:SPEed?	Querying the sampling time (measurement speed)	
	:MEASure:DElay <Measurement delay time>	Setting the measurement delay time	p. 142
	:MEASure:DElay?	Querying the measurement delay time	
	:CHARge LIMit <Current limit value>	Setting the current limit value	p. 142
	:CHARge:LIMit?	Querying the current limit value	
	:CHARge:LIMit:AUTO {ON OFF}	Setting the auto current limit	p. 143
	:CHARge:LIMit:AUTO?	Querying the auto current limit	
	:CHARge:TIME <Charging time>	Setting the charging time	p. 143
	:CHARge:TIME?	Querying the charging time	
	:CHARge:CAPacity <Capacitance value of the DUT>	Setting the capacitance value of the DUT	p. 144
	:CHARge:CAPacity?	Querying the capacitance value of the DUT	
:CHARge:CAPacity:AUTO {ON OFF}	Setting the auto capacitance value of the DUT	p. 144	
:CHARge:CAPacity:AUTO?	Querying the auto capacitance value of the DUT		
Contact check	:CONTactcheck {ON OFF}	Setting whether to enable or disable the contact check function	p. 145
	:CONTactcheck?	Querying whether to enable or disable the contact check function	
	:CONTactcheck:CAPacitance:THReshold <Threshold value>	Setting the judgment threshold value of the contact check	p. 145
	:CONTactcheck:CAPacitance:THReshold?	Querying the judgment threshold value of the contact check	
	:CONTactcheck:EXECute	Executing the contact check	p. 145
	:CONTactcheck:CAPacitance?	Querying the contact check capacitance value	p. 146
	:CONTactcheck:RESult?	Querying the contact check judgment result	p. 146

Category	Communications command	Functions	Reference
BDD	<code>:BDD:CC:V {ON OFF}</code>	Setting the BDD judgment based on the CC (charging) voltage	p. 146
	<code>:BDD:CC:V?</code>	Querying the BDD judgment using the CC (charging) voltage	
	<code>:BDD:CC:V:THReshold <Threshold value></code>	Setting the threshold value for the BDD judgment using the CC (charging) voltage	p. 147
	<code>:BDD:CC:V:THReshold?</code>	Querying the threshold value for the BDD judgment using the CC (charging) voltage	
	<code>:BDD:CV:V {ON OFF}</code>	Setting the BDD judgment using the CV (steady state) voltage	p. 147
	<code>:BDD:CV:V?</code>	Querying the BDD judgment using the CV (steady state) voltage	
	<code>:BDD:CV:V:THReshold <Threshold value></code>	Setting the threshold value for the BDD judgment using the CV (steady state) voltage	p. 148
	<code>:BDD:CV:V:THReshold?</code>	Querying the threshold value for the BDD judgment using the CV (steady state) voltage	
	<code>:BDD:CV:I {ON OFF}</code>	Setting the BDD judgment using the CV (steady state) current	p. 148
	<code>:BDD:CV:I?</code>	Querying the BDD judgment using the CV (steady state) current	
	<code>:BDD:CV:I:THReshold <Threshold value (%)></code>	Setting the threshold value % for the BDD judgment using the CV (steady state) current	p. 149
	<code>:BDD:CV:I:THReshold?</code>	Querying the threshold value % for the BDD judgment using the CV (steady state) current	
	<code>:BDD:COUNT? [{CCV CVV CVI}]</code>	Querying the BDD count saved in the memory	p. 149
	<code>:BDD:MEMory? [CRLF,{CCV CVV CVI}]</code>	Querying the BDD measured values saved in the memory	p. 150
	<code>:BDD:STOP {ON OFF}</code>	Setting the BDD stop function	p. 150
<code>:BDD:STOP?</code>	Querying the BDD stop function		
Test time	<code>TIMer <Test time></code>	Setting test time (timer)	p. 151
	<code>:TIMer?</code>	Querying test time (timer)	

Category	Communications command	Functions	Reference
Comparator	<code>:COMParator:DELay <Comparator delay time></code>	Setting the comparator delay time	p. 151
	<code>:COMParator:DELay?</code>	Querying the comparator delay time	
	<code>:COMParator:LIMit <Upper limit>,<Lower limit></code>	Setting the comparator upper/lower limit values	p. 152
	<code>:COMParator:LIMit?</code>	Querying the comparator upper/lower limit values	
	<code>:COMParator:MODE <Test mode></code>	Setting the comparator test mode	p. 152
	<code>:COMParator:MODE?</code>	Querying the comparator test mode	
	<code>:COMParator:BDD {ON OFF}</code>	Setting the BDD judgment for the comparator	p. 153
	<code>:COMParator:BDD?</code>	Querying the BDD judgment setting for the comparator	
	<code>:COMParator:BEEPer <Beep></code>	Setting the comparator beep	p. 153
	<code>:COMParator:BEEPer?</code>	Querying the comparator beep	
	<code>:COMParator:BEEPer:TONE <Beep tone></code>	Setting the comparator beep tone	p. 154
	<code>:COMParator:BEEPer:TONE?</code>	Querying the comparator beep tone	
Saving and loading the measurement conditions	<code>*SAV <Panel number></code> <code>[:SYSTem] :PANel :SAVE <Panel number></code>	Saving measurement conditions (panel saving)	p. 154
	<code>*SAV? <Panel number></code> <code>[:SYSTem] :PANel :SAVE? <Panel number></code>	Querying whether to perform panel save	
	<code>*RCL <Panel number></code> <code>[:SYSTem] :PANel :LOAD <Panel number></code>	Loading measurement conditions (panel loading)	p. 155
	<code>[:SYSTem] :PANel :CLEar <Panel number></code>	Deleting the saved measurement conditions (panel deletion)	p. 155
	<code>[:SYSTem] :PANel :NAME <Panel number>,<"Panel name"></code>	Setting the panel name	p. 155
	<code>[:SYSTem] :PANel :NAME? <Panel number></code>	Querying the panel name	

Communications Command List

Category	Communications command	Functions	Reference
System settings	:KEY:BEEPer {ON OFF}	Setting the beep for key input	p. 156
	:KEY:BEEPer?	Querying the beep for key input	
	:DISPlay:CONTrast <Contrast>	Setting the LCD contrast	p. 156
	:DISPlay:CONTrast?	Querying the LCD contrast	
	:DISPlay:BACKlight <Backlight>	Setting the LCD backlight	p. 157
	:DISPlay:BACKlight?	Querying the LCD backlight	
	:SYSTem:LFRequency <Power supply frequency>	Setting the power supply frequency	p. 157
	:SYSTem:LFRequency?	Querying the power supply frequency	
	:SYSTem:LFRequency:AUTO?	Querying the automatically detected power supply frequency	p. 158
	:SYSTem:KLOCK {ON OFF}	Setting the key lock state	p. 158
	:SYSTem:KLOCK?	Querying the key lock state	
	:SYSTem:KLOCK:PASSCode {ON OFF} [, <"Passcode">]	Setting the key lock passcode	p. 159
	:SYSTem:KLOCK:PASSCode?	Querying the key lock passcode	
	:IO:MODE?	Querying the EXT. I/O NPN/PNP switch status	p. 159
	:SYSTem:FPGA? [<Type>]	Querying the FPGA version number	p. 159
	:SYSTem:ADJusted:DATE?	Querying the adjustment date	p. 160
:SYSTem:CALibrated:DATE?	Querying the calibration date	p. 160	
:SYSTem:RESet	Changing the settings to the default settings (except for the communications settings)	p. 160	
RS-232C	:SYSTem:COMMunicate:RS232C:SPEEd <Communications speed>	Setting the RS-232C communications speed	p. 161
	:SYSTem:COMMunicate:RS232C:SPEEd?	Querying the RS-232C communications speed	

Category	Communications command	Functions	Reference
LAN	<code>:SYSTem:COMMunicate:LAN:IPADdress <Number 1>,<Number 2>,<Number 3>,<Number 4></code>	Setting the LAN IP address	p. 162
	<code>:SYSTem:COMMunicate:LAN:IPADdress?</code>	Querying the LAN IP address	
	<code>:SYSTem:COMMunicate:LAN:IPADdress:PREParation?</code>	Querying the LAN IP address to be enabled after confirmation of the LAN settings	p. 162
	<code>:SYSTem:COMMunicate:LAN:SMASk <Number 1>,<Number 2>,<Number 3>,<Number 4></code>	Setting the LAN subnet mask	p. 163
	<code>:SYSTem:COMMunicate:LAN:SMASk?</code>	Querying the LAN subnet mask	
	<code>:SYSTem:COMMunicate:LAN:SMASk:PREParation?</code>	Querying the LAN subnet mask to be enabled after confirmation of the LAN settings	p. 163
	<code>:SYSTem:COMMunicate:LAN:GATeway <Number 1>,<Number 2>,<Number 3>,<Number 4></code>	Setting the LAN default gateway	p. 164
	<code>:SYSTem:COMMunicate:LAN:GATeway?</code>	Querying the LAN default gateway	
	<code>:SYSTem:COMMunicate:LAN:GATeway:PREParation?</code>	Querying the LAN default gateway to be enabled after confirmation of the LAN settings	p. 164
	<code>:SYSTem:COMMunicate:LAN:CONTRol <Port number></code>	Setting the LAN port number	p. 165
	<code>:SYSTem:COMMunicate:LAN:CONTRol?</code>	Querying the LAN port number	
	<code>:SYSTem:COMMunicate:LAN:CONTRol:PREParation?</code>	Querying the LAN port number to be enabled after confirmation of the LAN settings	p. 165
	<code>:SYSTem:COMMunicate:LAN:UPDate</code>	Confirming the LAN settings	p. 166
	<code>:SYSTem:COMMunicate:LAN:MAC?</code>	Querying the MAC address	p. 166
Communications settings	<code>:SYSTem:COMMunicate:DATAout <Interface>,<Output type></code>	Setting the auto data output function	p. 167
	<code>:SYSTem:COMMunicate:DATAout?</code>	Querying the auto data output function	p. 168
	<code>:SYSTem:COMMunicate:MONitor {ON OFF}</code>	Setting the command monitor function	p. 169
	<code>:SYSTem:COMMunicate:MONitor?</code>	Querying the command monitor function	p. 169
	<code>:SYSTem:LOCAl</code>	Returning to the local state	p. 169

Command lower case letters can be omitted. Commands with both upper case and lower case letters are accepted.

8.9 Communications Command Reference

Command format example

2	Setting the power supply frequency	
3	Syntax	Command <code>:SYSTem:LFRequency <Power supply frequency></code> <hr/> • Power supply frequency {AUTO 50 60} Sets the power supply frequency.
4	Description	Specifies the power supply frequency. AUTO The power supply frequency (50 Hz or 60 Hz) is automatically detected at the time of startup. 50 The power supply frequency is set to 50 Hz. 60 The power supply frequency is set to 60 Hz.
5	Example	:SYSTem:LFRequency 60 The power supply frequency is set to 60 Hz.

1	< >	Characters in these symbols indicate a parameter required for sending a command.
	[]	Characters in these brackets can be omitted.
	{ }	Placing characters in these brackets indicates that one of the items in these brackets needs to be selected. Items are separated with a vertical bar (). Numerical values in these brackets indicate a setting range.
2	Indicates command information.	
3	Indicates the syntax of communications commands. The command data or response message is described.	
4	Describes the command.	
5	Indicates an example of using the actual command.	

The blank (0x20) in the query example is indicated as “`␣`”.

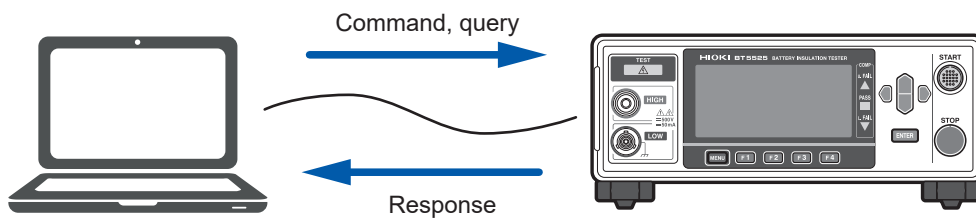

Standard command

Querying the instrument ID (Identification Code)		
Syntax	Query	*IDN?
	Response (28 bytes + CRLF)	<p><Manufacturer name>,<Model name>,<Serial number>,<Version></p> <hr/> <ul style="list-style-type: none"> • Manufacturer name: HIOKI • Model name: BT5525 • Manufacturing serial number: Returns the serial number. • Version: Returns the software version number.
Description	Queries the character string that identifies the instrument.	
Example	*IDN? HIOKI ,BT5525 ,210612345 ,V1 . 00	

Changing the settings to the default settings (except for the communications settings)		
Syntax	Command	*RST
Description	Sets the instrument to the default settings. The communications settings, however, are not changed. When the command is executed during the test, an execution error occurs. See "11.9 Default Setting" (p. 214)	
Example	*RST	

Executing a self-test		
Syntax	Query	*TST?
	Response (4 bytes + CRLF)	<p><Result></p> <hr/> <p>Result{PASS FAIL}</p>
Description	Executes a self-test for the instrument and returns the result. PASS is returned when the instrument passes the test. Repair is necessary if FAIL is returned. Please contact your authorized Hioki distributor or reseller.	
Example	*TST? PASS A self-test has been executed and it has found no problem.	

Waiting for the current operation to complete and setting the operation completion bit of the Standard Event Status Register (SESR) to 1

Syntax	Command	*OPC
Description	Sets the OPC bit of the Standard Event Status Register (SESR) to 1 when the current operation is completed. The subsequent command is not executed until the current operation is completed.	
Example	*OPC *ESR? 1	

Waiting for the current operation to complete and returning 1

Syntax	Query	*OPC?
	Response (1 byte + CRLF)	1
Description	Waits for the current operation to complete and returns 1. The subsequent command is not executed until the current operation is completed.	
Example	*OPC? 1 The previous operation has been completed.	

Waiting for the current operation to complete

Syntax	Command	*WAI
Description	Waits for the current operation to complete. The subsequent command is not executed until the current operation is completed. Unlike *OPC , "1" is not set to the OPC bit of the Standard Event Status Register (SESR). Otherwise, everything else is the same as *OPC .	

Event Register

Clearing the Event Status Register		
Syntax	Command	*CLS
Description	Clears the Event Status Register. The Status Byte Register (STB) bits corresponding to the event register are also cleared. Errors are cleared as well.	

Setting the Standard Event Status Enable Register (SESER)																		
Syntax	Command (1 to 3 bytes + CRLF)	*ESE <Mask> • Mask {0 to 255} Mask value to be set																
Description	Sets a mask pattern for the Standard Event Status Enable Register (SESER) with a numerical value between 0 and 255. The initial value when the instrument is turned on is 0. When an event corresponding to the specified bit occurs, "1" is set for the ESB bit of the Status Byte Register (STB).																	
	<table border="1" style="width: 100%; text-align: center;"> <tr> <td>Bit 7</td> <td>Bit 6</td> <td>Bit 5</td> <td>Bit 4</td> <td>Bit 3</td> <td>Bit 2</td> <td>Bit 1</td> <td>Bit 0</td> </tr> <tr> <td>PON</td> <td>(URQ)</td> <td>CME</td> <td>EXE</td> <td>DDE</td> <td>QYE</td> <td>(RQC)</td> <td>OPC</td> </tr> </table>		Bit 7	Bit 6	Bit 5	Bit 4	Bit 3	Bit 2	Bit 1	Bit 0	PON	(URQ)	CME	EXE	DDE	QYE	(RQC)	OPC
Bit 7	Bit 6	Bit 5	Bit 4	Bit 3	Bit 2	Bit 1	Bit 0											
PON	(URQ)	CME	EXE	DDE	QYE	(RQC)	OPC											
Example	*ESE 1 When "1" is set for the OPC bit of the Standard Event Status Enable Register (SESER), "1" is set for the ESB bit of the Status Byte Register (STB).																	

Querying the Standard Event Status Enable Register (SESER)		
Syntax	Query	*ESE?
	Response (1 to 3 bytes + CRLF)	<Mask> • Mask {0 to 255} Current mask value
Description	Queries the settings of the Standard Event Status Enable Register (SESER).	
Example	*ESE? 1 "1" has been set for the OPC bit of the Standard Event Status Enable Register (SESER).	

Querying the Standard Event Status Register (SESR)																		
Syntax	Query	*ESR?																
	Response (1 to 3 bytes + CRLF)	<Register value> • Register value {0 to 255} Current SESR value																
Description	Queries the Standard Event Status Register (SESR) value.																	
	<table border="1" style="width: 100%; text-align: center;"> <tr> <td>Bit 7</td> <td>Bit 6</td> <td>Bit 5</td> <td>Bit 4</td> <td>Bit 3</td> <td>Bit 2</td> <td>Bit 1</td> <td>Bit 0</td> </tr> <tr> <td>PON</td> <td>0</td> <td>CME</td> <td>EXE</td> <td>DDE</td> <td>QYE</td> <td>0</td> <td>OPC</td> </tr> </table>		Bit 7	Bit 6	Bit 5	Bit 4	Bit 3	Bit 2	Bit 1	Bit 0	PON	0	CME	EXE	DDE	QYE	0	OPC
Bit 7	Bit 6	Bit 5	Bit 4	Bit 3	Bit 2	Bit 1	Bit 0											
PON	0	CME	EXE	DDE	QYE	0	OPC											
Example	*OPC *ESR? 1 "1" is set for the OPC bit of the Standard Event Status Register (SESR) with *OPC .																	

Setting the Service Request Enable Register (SRER)																		
Syntax	Command	<p>*SRE <Mask></p> <hr/> <ul style="list-style-type: none"> Mask {0 to 255} Mask value to be set 																
Description	<p>Sets a mask pattern for the Service Request Enable Register (SRER) with a numerical value between 0 and 255. The initial value when the instrument is turned on is 0. When "1" is set for the bit corresponding to the specified bit, "1" is set for the MSS bit of the Status Byte Register (STB).</p> <table border="1" style="width: 100%; text-align: center;"> <tr> <td>Bit 7</td> <td>Bit 6</td> <td>Bit 5</td> <td>Bit 4</td> <td>Bit 3</td> <td>Bit 2</td> <td>Bit 1</td> <td>Bit 0</td> </tr> <tr> <td>0</td> <td>0</td> <td>ESB</td> <td>MAV</td> <td>0</td> <td>ERR</td> <td>0</td> <td>0</td> </tr> </table>		Bit 7	Bit 6	Bit 5	Bit 4	Bit 3	Bit 2	Bit 1	Bit 0	0	0	ESB	MAV	0	ERR	0	0
Bit 7	Bit 6	Bit 5	Bit 4	Bit 3	Bit 2	Bit 1	Bit 0											
0	0	ESB	MAV	0	ERR	0	0											
Example	<p>*SRE 4</p> <p>When a system error occurs, "1" is set for the MSS bit of the Status Byte Register (STB).</p>																	
Querying the Service Request Enable Register (SRER)																		
Syntax	Query	*SRE?																
	Response (1 to 3 bytes + CRLF)	<p><Mask></p> <hr/> <ul style="list-style-type: none"> Mask {0 to 255} Current mask value 																
Description	Queries the Service Request Enable Register (SRER) value.																	
Example	<p>*SRE?</p> <p>4</p> <p>"1" has been set for the ERR bit of the Service Request Enable Register (SRER).</p>																	

Querying the Status Byte Register (STB)																		
Syntax	Query	*STB?																
	Response (1 to 3 bytes + CRLF)	<p><Mask></p> <hr/> <ul style="list-style-type: none"> Mask{0 to 255} Current STB value 																
Description	<p>Queries the Status Byte Register (STB) value.</p> <table border="1" style="width: 100%; text-align: center;"> <tr> <td>Bit 7</td> <td>Bit 6</td> <td>Bit 5</td> <td>Bit 4</td> <td>Bit 3</td> <td>Bit 2</td> <td>Bit 1</td> <td>Bit 0</td> </tr> <tr> <td>-</td> <td>MSS</td> <td>ESB</td> <td>MAV</td> <td>-</td> <td>ERR</td> <td>-</td> <td>-</td> </tr> </table>		Bit 7	Bit 6	Bit 5	Bit 4	Bit 3	Bit 2	Bit 1	Bit 0	-	MSS	ESB	MAV	-	ERR	-	-
Bit 7	Bit 6	Bit 5	Bit 4	Bit 3	Bit 2	Bit 1	Bit 0											
-	MSS	ESB	MAV	-	ERR	-	-											
Example	<p>*STB?</p> <p>4</p> <p>"1" has been set for the ERR bit of the Status Byte Register (STB).</p>																	

Error

Reading and clearing errors		
Syntax	Query	<code>:SYSTem:ERRor?</code>
	Response (17 to 25 bytes + CRLF)	<code>Error number, "Error description"</code>
Description	Returns and clears the error, if any. When an error occurs, "1" is set for the ERR bit of the Status Byte Register (STB) until the error is read by this command or <code>*CLS</code> is executed. An instrument error, however, is not cleared. When an instrument error occurs, the EXT. I/O ERROR terminal output is turned ON. For details about the error, see "Before requesting repair" (p. 195).	
Example	<code>:SYSTem:ERRor?</code> <code>-388, "Adjust _data _lost"</code> The adjustment data of the instrument is corrupted.	

Measurement control

Starting the test		
Syntax	Command	<code>:START</code>
Description	Starts the test. An execution error occurs if this command is executed when the test cannot be started. For instance, an execution error occurs while a test is being performed, an interlock is activated, the EXT. I/O STOP signal is ON, etc.	
Example	<code>:START</code> Starts the test.	

Ending the test		
Syntax	Command	<code>:STOP</code>
Description	Ends the test.	
Example	<code>:STOP</code> Ends the test.	

Querying the measurement status		
Syntax	Query	:STATe?
	Response (1 byte + CRLF)	<Measurement status> ----- • Measurement status {0 to 3} Returns the measurement status.
Description	Queries the measurement status. 0 Stopped 1 During execution of a contact check or resistance measurement 2 During execution of discharge 3 Stopped since the interlock is activated and measurement cannot be started	
Example	:STATe? 1 The measurement status is currently executing a contact check or resistance measurement.	

Measurement command

Setting the response details of measured values																										
Syntax	Command	:MEASure:VALid <Response details> ----- • Response details {0 to 255} Specifies the response details of measured values.																								
	Description	Specifies the response details as a sum of bits when the measured value is returned. For example, 6 is specified as the logical sum of bit 1 (2) and bit 2 (4) if the measurement status and resistance value are set as a response description.																								
<table border="1" style="width:100%; text-align:center; border-collapse: collapse;"> <tr> <td>Bit 7</td><td>Bit 6</td><td>Bit 5</td><td>Bit 4</td><td>Bit 3</td><td>Bit 2</td><td>Bit 1</td><td>Bit 0</td></tr> <tr> <td>128</td><td>64</td><td>32</td><td>16</td><td>8</td><td>4</td><td>2</td><td>1</td></tr> <tr> <td>Contact check result</td><td>BDD result</td><td>Current value (A)</td><td>Voltage value (V)</td><td>Result</td><td>Resistance value (Ω)</td><td>Measurement status</td><td>Time stamp</td></tr> </table>			Bit 7	Bit 6	Bit 5	Bit 4	Bit 3	Bit 2	Bit 1	Bit 0	128	64	32	16	8	4	2	1	Contact check result	BDD result	Current value (A)	Voltage value (V)	Result	Resistance value (Ω)	Measurement status	Time stamp
Bit 7	Bit 6	Bit 5	Bit 4	Bit 3	Bit 2	Bit 1	Bit 0																			
128	64	32	16	8	4	2	1																			
Contact check result	BDD result	Current value (A)	Voltage value (V)	Result	Resistance value (Ω)	Measurement status	Time stamp																			
Example	:MEASure:VALid 6 The response description is set so that the measurement status and resistance value are returned.																									
Querying the response details of measured values																										
Syntax	Query	:MEASure:VALid?																								
	Response (3 bytes + CRLF)	<Response description> ----- • Response details {0 to 255} Returns the response details setting of the measured value as a sum of bits.																								
Description	Queries the response details setting of measured values.																									
<table border="1" style="width:100%; text-align:center; border-collapse: collapse;"> <tr> <td>Bit 7</td><td>Bit 6</td><td>Bit 5</td><td>Bit 4</td><td>Bit 3</td><td>Bit 2</td><td>Bit 1</td><td>Bit 0</td></tr> <tr> <td>128</td><td>64</td><td>32</td><td>16</td><td>8</td><td>4</td><td>2</td><td>1</td></tr> <tr> <td>Contact check result</td><td>BDD result</td><td>Current value (A)</td><td>Voltage value (V)</td><td>Result</td><td>Resistance value (Ω)</td><td>Measurement status</td><td>Time stamp</td></tr> </table>			Bit 7	Bit 6	Bit 5	Bit 4	Bit 3	Bit 2	Bit 1	Bit 0	128	64	32	16	8	4	2	1	Contact check result	BDD result	Current value (A)	Voltage value (V)	Result	Resistance value (Ω)	Measurement status	Time stamp
Bit 7	Bit 6	Bit 5	Bit 4	Bit 3	Bit 2	Bit 1	Bit 0																			
128	64	32	16	8	4	2	1																			
Contact check result	BDD result	Current value (A)	Voltage value (V)	Result	Resistance value (Ω)	Measurement status	Time stamp																			
Example	:MEASure:VALid? ␣13 The time stamp, resistance value, and judgment result are returned.																									

Setting the over-range value response type		
Syntax	Command	<code>:MEASure:FORMat:OVER {TYPE1 TYPE2}</code>
Description	Sets the response type when a resistance value that exceeded the resistance range is acquired using a command. TYPE1 Returns <code>9999E+07</code> as the over-range value, regardless of the range. TYPE2 Returns the maximum value that can be measured with the current range. Since the returned value cannot be distinguished from a normally measured value, acquire the measurement status at the same time and check whether the range was exceeded. See over-range value format of the <code>:MEASure?</code> command.	
Example	<code>:MEASure:FORMat:OVER TYPE2</code> Set the response type to TYPE 2 setting for the over-range values.	
Querying the over-range value response type		
Syntax	Query	<code>:MEASure:FORMat:OVER?</code>
	Response (5 bytes + CRLF)	<code>{TYPE1 TYPE2}</code>
Description	Queries the response type when a resistance value that exceeded the resistance range is acquired using a command.	
Example	<code>:MEASure:FORMat:OVER?TYPE1</code> Over-range values will be returned with the TYPE1 setting.	

Measured value output

Querying the measured value		
Syntax	Query	<code>:MEASure?</code>
	Response (0 to 60 bytes + CRLF)	<code><Measured value></code>
Description	Queries the latest measured value. After the test is completed, the last measured value is returned. The response description is specified by <code>:MEASure:VALid</code> (Setting the response details of measured values). In the default setting, only the resistance value is returned. (See the figure below.)	
Example	<code>:MEASure?123.4E+06</code> The resistance value is 123.4 MΩ.	

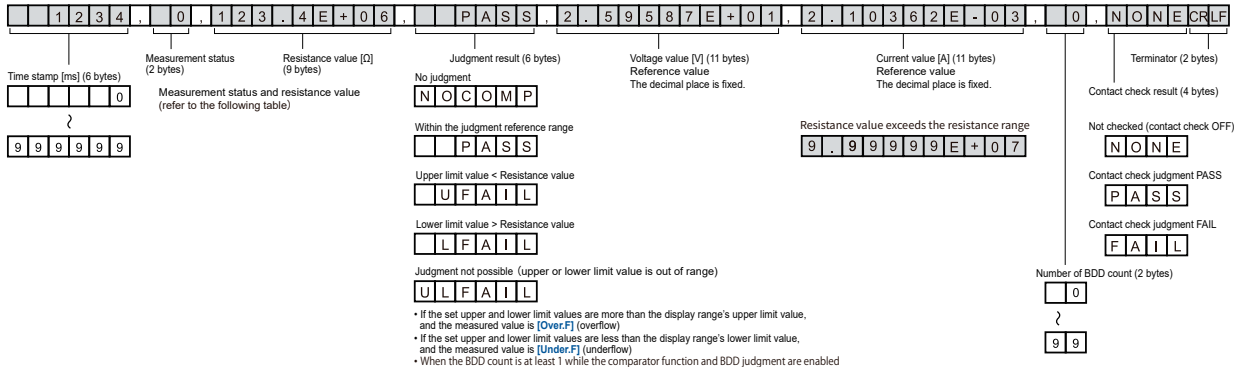

Priority	Measurement result	Description	Measurement status	Resistance value
High	Instrument error	A hardware error occurred, and the instrument was unable to make a measurement. For more information, see "Before requesting repair" (p. 195)	99	0000E+10
	Overheat error	Testing was forcibly stopped due to a current limit imposed to prevent heating of the circuit. Testing can be performed after 1 second.	20	0000E+10
	Contact check FAIL	Testing was stopped because the DUT's capacitance value was less than the set threshold value. Please check the connection. This status is valid only when the contact check function is enabled.	14	0000E+10
	Under range	The measured value is less than the lower limit of the current range's measurable range.	-7	0000E+07
	Over range	The measured value is more than the upper limit of the current range's measurable range.	7	*1
	Measured value invalid (not measured)	Testing ended before measurement completed.	-1	0000E+10
	Normal	–	0	*2
Low	Not measured	No value was measured.	1	0000E+10

*1: Over-range value format

TYPE	Over-range value
TYPE1	All range <div style="border: 1px solid black; display: inline-block; padding: 2px;"> 9 9 9 9 E + 0 7 </div>
TYPE2	2 MΩ range <div style="border: 1px solid black; display: inline-block; padding: 2px;"> 9 . 9 9 9 E + 0 6 </div>
	20 MΩ range <div style="border: 1px solid black; display: inline-block; padding: 2px;"> 9 9 . 9 9 E + 0 6 </div>
	200 MΩ range, less than auto-range 100 V <div style="border: 1px solid black; display: inline-block; padding: 2px;"> 9 9 9 . 9 E + 0 6 </div>
	2000 MΩ range, equal to or more than auto-range 100 V <div style="border: 1px solid black; display: inline-block; padding: 2px;"> 9 9 9 9 E + 0 6 </div>

*2: Numerical format for measured values

Range	Normal value
2 MΩ	<div style="border: 1px solid black; display: inline-block; padding: 2px;"> X . X X X E + 0 6 </div>
20 MΩ	<div style="border: 1px solid black; display: inline-block; padding: 2px;"> X X . X X E + 0 6 </div>
200 MΩ	<div style="border: 1px solid black; display: inline-block; padding: 2px;"> X X X . X E + 0 6 </div>
2000 MΩ	<div style="border: 1px solid black; display: inline-block; padding: 2px;"> X X X X E + 0 6 </div>
Auto	<div style="border: 1px solid black; display: inline-block; padding: 2px;"> X X X X X E + 0 6 </div> <p>Numerical format for the confirmed range</p>

Querying the voltage monitor value		
Syntax	Query	<code>:MEASure:MONItor?</code>
	Response (3 bytes + CRLF)	<code><Voltage monitor value></code> ----- • Voltage monitor value {25 to 500} Returns the voltage monitor value.
Description	Queries the voltage monitor value.	
Example	<code>:MEASure:MONItor?</code> <code>␣ 35</code> The voltage monitor value is 35 V.	

Clearing the measured value		
Syntax	Command	<code>:MEASure:CLear</code>
Description	Clears the measured value and judgment result. The judgment is determined to be no judgment.	
Example	<code>:MEASure:CLear</code> Clears the measured value and judgment result.	

Querying the number of measured values saved in the memory		
Syntax	Query	<code>:MEASure:COUNT?</code>
	Response (3 bytes + CRLF)	<code><Number of measured values in the memory></code> ----- • Number of measured values saved in the memory {0 to 999} Returns the number of measured values saved in the memory.
Description	Queries the number of measured values saved in the memory. As the test starts, the memory is cleared once and then the measured values are saved in the internal memory for each sampling. Up to 999 measured values can be saved in the memory and any measured values from samplings taking place after that are not saved. By querying the number of measured values saved in the memory, you can find out the number of measured values returned with the <code>:MEASure:MEMory?</code> query.	
Example	<code>:MEASure:COUNT?</code> <code>␣ 23</code> 23 measured values are saved in the memory.	

Querying the measured values saved in the memory		
Syntax	Query	<code>:MEASure:MEMory? [CRLF]</code>
	Response	<code><Measured value 1>,<Measured value 2>,<Measured value 3>,...<Measured value N></code>
Description	Queries all the measured values saved in the memory. The measured values are returned with comma delimiters. When <code>CRLF</code> is specified as an option, they are returned with line break (<code>CRLF</code>) delimiters. The number of measured values (N), can be checked with the <code>:MEASure:COUNT?</code> query. The response description is specified by <code>:MEASure:VALid</code> (Setting the response details of measured values). See the <code>:MEASure?</code> query for the measured value response format. An execution error occurs if the measured values are not saved in the memory.	
Example	<code>:MEASure:MEMory?</code> <code>120.0E+06,123.4E+06,124.5E+06,130.9E+06,150.0E+06</code> Five measured values are saved in the memory and the respective resistance values are 120.0 MΩ, 123.4 MΩ, 124.5 MΩ, 130.9 MΩ, and 150.0 MΩ.	

Measurement settings

Setting the test voltage		
Syntax	Command	:VOLTAge <Test voltage> ----- • Test voltage {25 to 500} Sets the test voltage.
Description	Specifies the test voltage. Sending this command causes instrument operation to stop for 1 second so that the internal circuit's voltage can stabilize. Add a timeout of at least 1 second to query responses.	
Example	:VOLTAge 100 The test voltage is set to 100 V. If you set the test voltage to 99 V or less when the range is preset to 2000 MΩ, the range is changed to 200 MΩ.	
Querying the test voltage		
Syntax	Query	:VOLTAge?
	Response (3 bytes + CRLF)	<Test voltage> ----- • Test voltage {25 to 500} Returns the test voltage.
Description	Queries the test voltage.	
Example	:VOLTAge? 100 The test voltage setting is 100 V.	

Setting the resistance range		
Syntax	Command	:RANGe <Resistance range> ----- • Resistance range {2M 20M 200M 2000M} Sets the resistance range.
Description	Specifies the resistance range. The 2000 MΩ range can be specified when the test voltage is 100 V or more. If the 2000 MΩ range is specified when the test voltage is less than 100 V, an execution error occurs.	
Example	:RANGe 20M The resistance range is set to 20 MΩ.	
Querying the resistance range		
Syntax	Query	:RANGe?
	Response (2 to 5 bytes + CRLF)	<Resistance range> ----- • Resistance range {2M 20M 200M 2000M} Returns the resistance range.
Description	Queries the resistance range.	
Example	:RANGe? 20M The resistance range setting is 20 MΩ.	

Setting the auto range		
Syntax	Command	<code>:RANGe:AUTO {ON OFF}</code>
Description	Sets the auto range so that the measurement range is automatically switched. ON The auto range function switches the range automatically. OFF The range does not switch automatically and is fixed. See “3.2 Setting the Range (Auto/Manual)” (p. 36).	
Example	<code>:RANGe:AUTO ON</code> The auto range is set to ON.	
Querying the auto range		
Syntax	Query	<code>:RANGe:AUTO?</code>
	Response (2 or 3 bytes + CRLF)	<code>{ON OFF}</code>
Description	Queries the auto range setting.	
Example	<code>:RANGe:AUTO?</code> <code>ON</code> The auto range is ON.	

Setting the sampling time (measurement speed)		
Syntax	Command	<code>:SPEed <Sampling time></code> ----- • Sampling time {1 to 100} Sets the sampling time.
	Description	Specifies the sampling time. The sampling time is set in the range between 1 PLC and 100 PLCs. 1 PLC is equivalent to one cycle of a power supply frequency. At 50 Hz, 1 PLC = 1/50 = 20 ms. At 60 Hz, 1 PLC = 1/60 = 16.7 ms. When the sampling time is long, the measured value is stable, however, the time until the measured value is confirmed becomes longer.
Example	<code>:SPEed 5</code> The sampling time is set to 5 PLCs.	
Querying the sampling time (measurement speed)		
Syntax	Query	<code>:SPEed?</code>
	Response (3 bytes + CRLF)	<code><Sampling time></code> ----- • Sampling time {1 to 100} Returns the sampling time.
Description	Queries the sampling time.	
Example	<code>:SPEed?</code> <code> 5</code> The sampling time setting is 5 PLCs.	

Setting the measurement delay time		
Syntax	Command	:MEASure:DElay <Measurement delay time> ----- • Measurement delay time {1 to 100} Sets the measurement delay time.
Description	Specifies the measurement delay time. The measurement delay time is set in the range between 1 PLC and 100 PLCs. 1 PLC is equivalent to one cycle of a power supply frequency. At 50 Hz, 1 PLC = 1/50 = 20 ms. At 60 Hz, 1 PLC = 1/60 = 16.7 ms.	
Example	:MEASure:DElay 5 The measurement delay time is set to 5 PLCs.	
Querying the measurement delay time		
Syntax	Query	:MEASure:DElay?
	Response (3 bytes + CRLF)	<Measurement delay time> ----- • Measurement delay time {1 to 100} Returns the measurement delay time.
Description	Queries the measurement delay time.	
Example	:MEASure:DElay? 5 The measurement delay time setting is 5 PLCs.	

Setting the current limit value		
Syntax	Command	:CHARge LIMit <Current limit value> ----- • Current limit value {0.05E-03 to 50.00E-03} Sets the current limit value.
Description	Specifies the current limit value. When this command is executed, the auto current limit setting is OFF (MANUAL).	
Example	:CHARge:LIMit 5E-3 The current limit value is set to 5 mA.	
Querying the current limit value		
Syntax	Query	:CHARge:LIMit?
	Response (9 bytes + CRLF)	<Current limit value> ----- • Current limit value {0.05E-03 to 50.00E-03} Returns the current limit value.
Description	Queries the current limit value.	
Example	:CHARge:LIMit? 5.00E-03 The current limit value setting is 5 mA.	

Setting the auto current limit		
Syntax	Command	<code>:CHARge:LIMit:AUTO {ON OFF}</code>
Description	<p>Allows the current limit value to be set automatically.</p> <p>ON The auto current limit function allows the current limit value to be set automatically. The limit value is calculated based on the charging time and capacitance value of the DUT.</p> <p>OFF The current limit value is not automatically set and is fixed.</p> <p>See “5.3 Limiting the Current to Be Applied to the Device Under Test (DUT)” (p. 64).</p>	
Example	<p><code>:CHARge:LIMit:AUTO ON</code> The auto current limit is set to ON (AUTO).</p>	
Querying the auto current limit		
Syntax	Query	<code>:CHARge:LIMit:AUTO?</code>
	Response (2 or 3 bytes + CRLF)	<code>{ON OFF}</code>
Description	Queries the auto current limit setting.	
Example	<p><code>:CHARge:LIMit:AUTO?</code> <code>ON</code> The auto current limit is ON (AUTO).</p>	

Setting the charging time		
Syntax	Command	<code>:CHARge:TIME <Charging time></code> <hr/> <ul style="list-style-type: none"> Charging time {0.001 to 10.000} Sets the charging time.
Description	Specifies the charging time. The charging time is used to calculate the current limit value.	
Example	<p><code>:CHARge:TIME 1</code> The charging time is set to 1 second.</p>	
Querying the charging time		
Syntax	Query	<code>:CHARge:TIME?</code>
	Response (6 bytes + CRLF)	<code><Charging time></code> <hr/> <ul style="list-style-type: none"> Charging time {0.001 to 10.000} Returns the charging time.
Description	Queries the charging time.	
Example	<p><code>:CHARge:TIME?</code> <code>1.000</code> The charging time setting is 1 second.</p>	

Setting the capacitance value of the DUT		
Syntax	Command	<code>:CHARge:CAPacity <Capacitance value of the DUT></code> • Capacitance value of the DUT {0.1E-09 to 200.0E-09} Sets the capacitance value of the DUT.
Description	Specifies the capacitance value of the DUT. The capacitance value of the DUT is used to calculate the current limit value. When this command is executed, the auto capacitance value setting is OFF (MANUAL).	
Example	<code>:CHARge:CAPacity 99E-09</code> The capacitance value of the DUT is set to 99 nF.	
Querying the capacitance value of the DUT		
Syntax	Query	<code>:CHARge:CAPacity?</code>
	Response (9 bytes + CRLF)	<code><Capacitance value of the DUT></code> • Capacitance value of the DUT {0.1E-09 to 200.0E-09} Returns the capacitance value of the DUT.
Description	Queries the capacitance value of the DUT.	
Example	<code>:CHARge:CAPacity?</code> <code> 99.0E-09</code> The capacitance value of the DUT is 99 nF.	

Setting the auto capacitance value of the DUT		
Syntax	Command	<code>:CHARge:CAPacity:AUTO {ON OFF}</code>
Description	Allows the capacitance value of the DUT to be set automatically. ON The capacitance value of the DUT is measured and the capacitance value is automatically set at the start of the test. OFF The capacitance value of the DUT is not automatically set and is fixed. See “5.3 Limiting the Current to Be Applied to the Device Under Test (DUT)” (p. 64).	
Example	<code>:CHARge:CAPacity:AUTO ON</code> The auto capacitance value of the DUT is set to ON (AUTO).	
Querying the auto capacitance value of the DUT		
Syntax	Query	<code>:CHARge:CAPacity:AUTO?</code>
	Response (2 or 3 bytes + CRLF)	<code>{ON OFF}</code>
Description	Queries the auto capacitance value of the DUT.	
Example	<code>:CHARge:CAPacity:AUTO?</code> <code>ON</code> The auto capacitance value of the DUT is ON (AUTO).	

Contact check

Setting whether to enable or disable the contact check function		
Syntax	Command	<code>:CONtactcheck {ON OFF}</code>
Description	Sets whether to enable or disable the contact check function.	
Example	<code>:CONtactcheck ON</code> The contact check function is set to ON at the start of the test.	
Querying whether to enable or disable the contact check function		
Syntax	Query	<code>:CONtactcheck?</code>
	Response (2 or 3 bytes + CRLF)	<code>{ON OFF}</code>
Description	Queries whether to enable or disable the contact check function.	
Example	<code>:CONtactcheck?</code> ON The contact check function is enabled.	

Setting the judgment threshold value of the contact check		
Syntax	Command	<code>:CONtactcheck:CAPacitance:THReshold <Threshold value></code>
		<ul style="list-style-type: none"> Threshold value {0.1E-09 to 100.0E-9} Sets the threshold value.
Description	Specifies the judgment threshold value of the contact check.	
Example	<code>:CONtactcheck:CAPacitance:THReshold 20E-9</code> The judgment threshold value of the contact check is set to 20 nF.	
Querying the judgment threshold value of the contact check		
Syntax	Query	<code>:CONtactcheck:CAPacitance:THReshold?</code>
	Response (9 bytes + CRLF)	<Threshold value> <ul style="list-style-type: none"> Threshold value {0.1E-09 to 100.0E-9} Returns the threshold value.
Description	Queries the judgment threshold value of the contact check.	
Example	<code>:CONtactcheck:CAPacitance:THReshold?</code> 20.0E-09 The judgment threshold value of the contact check is 20 nF.	

Executing the contact check		
Syntax	Command	<code>:CONtactcheck:EXECute</code>
Description	Performs a contact check. Executing this command when testing cannot be started will cause an execution error. For example, executing it while the interlock is activated or while the EXT. I/O STOP signal is ON will result in an execution error. It may take up to 50 ms from execution until completion. Query the contact check capacitance value and judgment result after the contact check completes.	
Example	<code>:CONtactcheck:EXECute</code> Performs a contact check.	

Querying the contact check capacitance value		
Syntax	Query	<code>:CONTactcheck:CAPacitance?</code>
	Response (9 bytes + CRLF)	<code><Capacitance value></code> ----- • Capacitance value {0.0E-09 to 200.0E-09 999.9E-09} Returns the capacitance value.
Description	Queries the capacitance value when a contact check is performed. When the capacitance value is 200 nF or more (OVER), 999.9E-09 is returned.	
Example	<code>:CONTactcheck:CAPacitance?</code> <code> 20.0E-09</code> The capacitance value for the contact check is 20 nF.	

Querying the contact check judgment result		
Syntax	Query	<code>:CONTactcheck:RESult?</code>
	Response (4 bytes + CRLF)	<code><Contact check judgment result></code> ----- • Contact check judgment result {NONE PASS FAIL} Returns the judgment result of the contact check.
Description	Returns the judgment result of the contact check. NONE The contact check function is disabled, or there is no judgment result (not measured). PASS The judgment result of the contact check is PASS. When the capacitance value is more than 200 nF (OVER), PASS is returned as well. FAIL The judgment result of the contact check is FAIL.	
Example	<code>:CONTactcheck:RESult?</code> <code>FAIL</code> The judgment result of the contact check is FAIL.	

BDD

Setting the BDD judgment based on the CC (charging) voltage		
Syntax	Command	<code>:BDD:CC:V {ON OFF}</code>
Description	Sets the BDD judgment using the CC (charging) voltage.	
Example	<code>:BDD:CC:V ON</code> The BDD judgment is set to be performed using the CC (charging) voltage.	
Querying the BDD judgment using the CC (charging) voltage		
Syntax	Query	<code>:BDD:CC:V?</code>
	Response (2 or 3 bytes + CRLF)	<code>{ON OFF}</code>
Description	Queries the BDD judgment setting using the CC (charging) voltage.	
Example	<code>:BDD:CC:V?</code> <code>ON</code> The BDD judgment using the CC (charging) voltage is set.	

Setting the threshold value for the BDD judgment using the CC (charging) voltage		
Syntax	Command	<code>:BDD:CC:V:THReshold <Threshold value></code> • Threshold value {0.1 to 500.0} Sets the threshold value.
Description	Specifies the threshold value.	
Example	<code>:BDD:CC:V:THReshold 1.5</code> The threshold value for the BDD judgment using the CC (charging) voltage is set to 1.5 V.	
Querying the threshold value for the BDD judgment using the CC (charging) voltage		
Syntax	Query	<code>:BDD:CC:V:THReshold?</code>
	Response (5 bytes + CRLF)	<code><Threshold value></code> • Threshold value {0.1 to 500.0} Returns the threshold value.
Description	Queries the threshold value.	
Example	<code>:BDD:CC:V:THReshold?</code> <code>␣␣1.5</code> The threshold value for the BDD judgment using the CC (charging) voltage is 1.5 V.	

Setting the BDD judgment using the CV (steady state) voltage		
Syntax	Command	<code>:BDD:CV:V {ON OFF}</code>
Description	Sets the BDD judgment using the CV (steady state) voltage.	
Example	<code>:BDD:CV:V ON</code> The BDD judgment is set to be performed using the CV (steady state) voltage.	
Querying the BDD judgment using the CV (steady state) voltage		
Syntax	Query	<code>:BDD:CV:V?</code>
	Response (2 or 3 bytes + CRLF)	<code>{ON OFF}</code>
Description	Queries the BDD judgment setting using the CV (steady state) voltage.	
Example	<code>:BDD:CV:V?</code> <code>ON</code> The BDD judgment is to be performed using the CV (steady state) voltage.	

Setting the threshold value for the BDD judgment using the CV (steady state) voltage		
Syntax	Command	<code>:BDD:CV:V:THReshold <Threshold value></code> • Threshold value {0.1 to 500.0} Sets the threshold value.
Description	Specifies the threshold value.	
Example	<code>:BDD:CV:V:THReshold 5.5</code> The threshold value for the BDD judgment using the CV (steady state) voltage is set to 5.5 V.	
Querying the threshold value for the BDD judgment using the CV (steady state) voltage		
Syntax	Query	<code>:BDD:CV:V:THReshold?</code>
	Response (5 bytes + CRLF)	<code><Threshold value></code> • Threshold value {0.1 to 500.0} Returns the threshold value.
Description	Queries the threshold value.	
Example	<code>:BDD:CV:V:THReshold?</code> <code>␣␣5.5</code> The threshold value for the BDD judgment using the CV (steady state) voltage is 5.5 V.	

Setting the BDD judgment using the CV (steady state) current		
Syntax	Command	<code>:BDD:CV:I {ON OFF}</code>
Description	Sets the BDD judgment using the CV (steady state) current.	
Example	<code>:BDD:CV:I ON</code> The BDD judgment is set to be performed using the CV (steady state) current.	
Querying the BDD judgment using the CV (steady state) current		
Syntax	Query	<code>:BDD:CV:I?</code>
	Response (2 or 3 bytes + CRLF)	<code>{ON OFF}</code>
Description	Queries the BDD judgment using the CV (steady state) current.	
Example	<code>:BDD:CV:I?</code> <code>ON</code> The BDD judgment is to be performed using the CV (steady state) current.	

Setting the threshold value % for the BDD judgment using the CV (steady state) current		
Syntax	Command	:BDD:CV:I:THReshold <Threshold value (%)> • Threshold value % {0.6 to 999.9} Sets the threshold value %.
Description	Specifies the threshold value %.	
Example	:BDD:CV:I:THReshold 5.5 The threshold value % for the BDD judgment using the CV (steady state) current is set to 5.5%.	
Querying the threshold value % for the BDD judgment using the CV (steady state) current		
Syntax	Query	:BDD:CV:I:THReshold?
	Response (5 bytes + CRLF)	<Threshold value %> • Threshold value % {0.6 to 999.9} Returns the threshold value %.
Description	Queries the threshold value %.	
Example	:BDD:CV:I:THReshold? 5.5 The threshold value % for the BDD judgment using the CV (steady state) current is 5.5%.	

Querying the BDD count saved in the memory		
Syntax	Query	:BDD:COUNT? [{CCV CVW CVI}]
	Response (2 bytes + CRLF)	<Number of measured values in the memory> • Number of measured values saved in the memory {0 to 99} Returns the BDD count saved in the memory.
Description	Queries the BDD count saved in the memory. If the optional BDD detection method is specified, the command will return the count detected using that method. As the test starts, the memory is cleared once and then the BDD measured values are saved in the internal memory. Up to 99 measured values can be saved in the memory and any BDD measured values after that are not saved. By querying the number of measured values saved in the memory, you can find out the number of measured values returned with the :BDD:MEMory? query.	
Example	:BDD:COUNT? 23 Twenty three BDD measured values are saved in the memory.	

Querying the BDD measured values saved in the memory											
Syntax	Query	<code>:BDD:MEMory? [CRLF, {CCV CVV CVI}]</code>									
	Response	<code><BDD measured value 1>,<BDD measured value 2>,<BDD measured value 3>,...,<BDD measured value N></code>									
Description	<p>Queries all the BDD measured values saved in the memory.</p> <p>If the optional BDD detection method is specified, the command returns the BDD measured value detected using that method.</p> <p>The BDD measured values are returned with comma delimiters. When CRLF is specified as an option, they are returned with line break (CRLF) delimiters.</p> <p>The number of BDD measured values, N, can be checked with the <code>:BDD:COUNT?</code> query. An execution error occurs if the BDD measured values are not saved in the memory.</p>										
<p>Response format</p> <p>Time stamp (ms) (10 bytes) Detection timing and type (3 bytes) Voltage value (V) or current value (%) (8 bytes)</p> <p>0 . 0 0 1 C C V 0 . 0 1</p> <p>to V is detected during CC. to</p> <p>9 9 9 9 9 9 . 9 9 9 C V V 9 9 9 9 9 . 9 9</p> <p> V is detected during CV.</p> <p>C V I</p> <p> I is detected during CV.</p>											
Example	<p><code>:BDD:MEMory?</code> <code>16.640,CCV, 1.21, 33.280,CCV, 1.89</code></p> <p>Two BDD measured values are saved in the memory and the result is as follows.</p> <table border="1"> <thead> <tr> <th>Time stamp</th> <th>Detection timing and type</th> <th>BDD measured value</th> </tr> </thead> <tbody> <tr> <td>16.640</td> <td>CCV</td> <td>1.21</td> </tr> <tr> <td>33.280</td> <td>CCV</td> <td>1.89</td> </tr> </tbody> </table>		Time stamp	Detection timing and type	BDD measured value	16.640	CCV	1.21	33.280	CCV	1.89
Time stamp	Detection timing and type	BDD measured value									
16.640	CCV	1.21									
33.280	CCV	1.89									

Setting the BDD stop function		
Syntax	Command	<code>:BDD:STOP {ON OFF}</code>
Description	Sets whether to stop the test when the BDD count is 1 or more.	
Example	<p><code>:BDD:STOP ON</code></p> <p>The test is set to stop when the BDD count is 1 or more.</p>	
Querying the BDD stop function		
Syntax	Query	<code>:BDD:STOP?</code>
	Response (2 or 3 bytes + CRLF)	<code>{ON OFF}</code>
Description	Queries whether to stop the test when the BDD count is 1 or more.	
Example	<p><code>:BDD:STOP?</code> <code>ON</code></p> <p>The test is to stop when the BDD count is 1 or more.</p>	

Test time

Setting test time (timer)		
Syntax	Command	TIMer <Test time> • Test time {0 0.050 to 999.999} Sets the test time.
Description	Sets the test time. 0 is specified to set the test time to OFF.	
Example	:TIMer 5 The test time is set to 5 seconds.	
Querying test time (timer)		
Syntax	Query	:TIMer?
	Response (7 bytes + CRLF)	<Test time> • Test time {0.000 0.050 to 999.999} Returns the test time.
Description	Queries the test time. 0.000 is returned when the test time is OFF.	
Example	:TIMer? ↵ 5.000 The test time setting is 5 seconds.	

Comparator

Setting the comparator delay time		
Syntax	Command	:COMParator:DElay <Comparator delay time> • Comparator delay time {0 0.001 to 999.999} Sets the comparator delay time.
Description	Specifies the comparator delay time. No comparator judgment is made during comparator delay. 0 is specified to set the comparator delay time to auto (AUTO).	
Example	:COMParator:DElay 10 The comparator delay time is set to 10 seconds.	
Querying the comparator delay time		
Syntax	Query	:COMParator:DElay?
	Response (7 bytes + CRLF)	<Comparator delay time> • Comparator delay time {0.000 0.001 to 999.999} Returns the comparator delay time.
Description	Queries the comparator delay time. 0.000 is returned when the comparator delay time is auto (AUTO).	
Example	:COMParator:DElay? ↵ 10.000 The comparator delay time setting is 10 seconds.	

Setting the comparator upper/lower limit values		
Syntax	Command	:COMParator:LIMit <Upper limit>,<Lower limit> ----- • Comparator upper limit {0.000E+06 to 9999E+06 OFF} Sets the comparator upper limit value. • Comparator lower limit {0.000E+06 to 9999E+06 OFF} Sets the comparator lower limit value.
Description	Specifies the comparator upper/lower limit values. Set the upper/lower limit values so that the upper limit value is equal to or more than the lower limit value. If the upper limit value is less than the lower limit value, an execution error occurs.	
Example	:COMParator:LIMit 5E6,2E6 The comparator upper limit value is set to 5 MΩ and the lower limit value to 2 MΩ.	
Querying the comparator upper/lower limit values		
Syntax	Query	:COMParator:LIMit?
	Response (19 bytes + CRLF)	<Upper limit>,<Lower limit> ----- • Comparator upper limit {0.000E+06 to 9999E+06 OFF} Returns the comparator upper limit value. • Comparator lower limit {0.000E+06 to 9999E+06 OFF} Returns the comparator lower limit value.
Description	Queries the comparator upper/lower limit values.	
Example	:COMParator:LIMit? 5.000E+06,2.000E+06 The comparator upper limit value is 5 MΩ and the lower limit value is 2 MΩ.	

Setting the comparator test mode		
Syntax	Command	:COMParator:MODE <Test mode> ----- • Test mode {CONTInue PASSstop FAILstop} Sets the comparator test mode.
Description	Specifies the comparator test mode. CONTInue The test is continued regardless of the comparator judgment result. PASSstop The test is ended when the comparator judgment result is PASS. FAILstop The test is ended when the comparator judgment result is FAIL.	
Example	:COMParator:MODE PASSstop The test is set to be ended when the comparator judgment result is PASS.	
Querying the comparator test mode		
Syntax	Query	:COMParator:MODE?
	Response (8 bytes + CRLF)	<Test mode> ----- • Test mode {CONTINUE PASSSTOP FAILSTOP} Returns the comparator test mode.
Description	Queries the comparator test mode.	
Example	:COMParator:MODE? PASSSTOP The test is to be ended when the comparator judgment result is PASS.	

Setting the BDD judgment for the comparator		
Syntax	Command	<code>:COMParator:BDD {ON OFF}</code>
Description	Sets whether to enable BDD judgment for comparator judgment results. OFF The comparator generates judgments based on measured insulation resistance values. ON BDD judgment is enabled in addition to comparator judgments based on measured insulation resistance values. A BDD count of 1 or greater results in a ULFAIL judgment. This setting is valid only when the comparator function is enabled.	
Example	<code>:COMParator:BDD ON</code> Enables BDD judgment.	
Querying the BDD judgment setting for the comparator		
Syntax	Query	<code>:COMParator:BDD?</code>
	Response (2 or 3 bytes + CRLF)	<code>{ON OFF}</code>
Description	Queries whether BDD judgment has been enabled for comparator judgment results.	
Example	<code>:COMParator:BDD?</code> <code>ON</code> BDD judgment is enabled.	

Setting the comparator beep		
Syntax	Command	<code>:COMParator:BEEPer <Beep></code> <hr/> • Beep {OFF PASS FAIL END} Sets the comparator beep.
Description	Specifies the comparator beep. OFF A comparator beep does not sound. PASS A comparator beep sounds when the judgment result is PASS. FAIL A comparator beep sounds when the judgment result is FAIL. END A comparator beep sounds when the test is completed regardless of the judgment result.	
Example	<code>:COMParator:BEEPer PASS</code> A beep is set to sound when the comparator judgment result is PASS.	
Querying the comparator beep		
Syntax	Query	<code>:COMParator:BEEPer?</code>
	Response (3 or 4 bytes + CRLF)	<code><Beep></code> <hr/> • Beep {OFF PASS FAIL END} Return the comparator beep.
Description	Queries the comparator beep.	
Example	<code>:COMParator:BEEPer?</code> <code>PASS</code> A beep is to be issued when the comparator judgment result is PASS.	

Setting the comparator beep tone		
Syntax	Command	:COMParator:BEEPer:TONE <Beep tone> ----- • Beep tone {1 2 3} Sets the comparator beep tone.
Description	Specifies the comparator beep tone. 1 High 2 Medium 3 Low	
Example	:COMParator:BEEPer:TONE 1 The comparator beep tone is set to high.	
Querying the comparator beep tone		
Syntax	Query	:COMParator:BEEPer:TONE?
	Response (1 byte + CRLF)	<Beep tone> ----- • Beep tone {1 2 3} Returns the comparator beep tone.
Description	Queries the comparator beep tone.	
Example	:COMParator:BEEPer:TONE? 1 The comparator beep tone is high.	

Saving and loading the measurement conditions

Saving measurement conditions (panel saving)		
Syntax	Command	*SAV <Panel number> or [:SYSTem] :PANel :SAVE <Panel number> ----- • Panel number {1 to 15} Specifies the panel number to which the measurement conditions are saved.
Description	Saves the current measurement conditions to the specified panel number. If a panel number to which measurement conditions have already been saved is specified, the current measurement conditions are saved to that panel number.	
Example	*SAV 1 The current measurement conditions are saved to panel number 1.	
Querying whether to perform panel save		
Syntax	Query	*SAV? <Panel number> or [:SYSTem] :PANel :SAVE? <Panel number> ----- • Panel number {1 to 15} Specifies the panel number to be queried.
	Response (1 byte + CRLF)	{0 1}
Description	Queries whether the measurement conditions are saved to the specified panel number. 0 The measurement conditions are not saved. 1 The measurement conditions are saved.	
Example	*SAV? 3 1 The measurement conditions are saved to panel number 3.	

Loading measurement conditions (panel loading)		
Syntax	Command	<p>*RCL <Panel number> or [:SYSTem] : PANel : LOAD <Panel number></p> <hr/> <ul style="list-style-type: none"> Panel number {1 to 15} Specifies the panel number to which the measurement conditions are loaded.
Description	Loads the measurement conditions saved to the specified panel number. If a panel number to which the measurement conditions have not been saved is specified, an execution error occurs.	
Example	<p>*RCL 1 The measurement conditions saved to panel number 1 are loaded.</p>	

Deleting the saved measurement conditions (panel deletion)		
Syntax	Command	<p>[:SYSTem] : PANel : CLear <Panel number></p> <hr/> <ul style="list-style-type: none"> Panel number {1 to 15} Specifies the panel number from which the measurement conditions are deleted.
Description	Deletes the measurement conditions saved to the specified panel number. Even if the panel number to which the measurement conditions have not been saved is specified, an execution error does not occur.	
Example	<p>:SYSTem : PANel : CLear 1 The measurement conditions saved to panel number 1 are deleted.</p>	

Setting the panel name		
Syntax	Command	<p>[:SYSTem] : PANel : NAME <Panel number> , <"Panel name"></p> <hr/> <ul style="list-style-type: none"> Panel number {1 to 15} Specifies the panel number to which the measurement conditions are saved. "Panel name" {Up to 10 one-byte characters in length} Specifies the panel name.
Description	Sets the panel name. The panel name is enclosed in double quotation marks ("").	
Example	<p>:SYSTem : PANel : NAME 3 , "HIOKI" The panel name for panel No. 3 is set to "HIOKI".</p>	

Querying the panel name		
Syntax	Query	<p>[:SYSTem] : PANel : NAME ? <Panel number></p> <hr/> <ul style="list-style-type: none"> Panel number {1 to 15} Specifies the panel number to be queried.
	Response (5 to 15 bytes + CRLF)	<p><Panel number> , <"Panel name"></p> <hr/> <ul style="list-style-type: none"> Panel number {1 to 15} "Panel name" {Up to 10 one-byte characters in length} Returns the panel name.
Description	Queries the panel name.	
Example	<p>:SYSTem : PANel : NAME ? 3 3 , "HIOKI" The panel name for panel No. 3 is "HIOKI".</p>	

System settings

Setting the beep for key input		
Syntax	Command	<code>:KEY:BEEPer {ON OFF}</code>
Description	Sets the beep for key input.	
Example	<code>:KEY:BEEPer ON</code> A beep is set to sound when key input is made.	
Querying the beep for key input		
Syntax	Query	<code>:KEY:BEEPer?</code>
	Response (2 or 3 bytes + CRLF)	<code>{ON OFF}</code>
Description	Queries the beep for key input.	
Example	<code>:KEY:BEEPer?</code> <code>ON</code> A beep is to be issued when key input is made.	

Setting the LCD contrast		
Syntax	Command	<code>:DISPlay:CONTrast <Contrast></code>
		<ul style="list-style-type: none"> A multiple of 5 within the contrast setting range of {0 to 100} Sets the LCD contrast.
Description	Specifies the LCD contrast.	
Example	<code>:DISPlay:CONTrast 60</code> The LCD contrast is set to 60.	
Querying the LCD contrast		
Syntax	Query	<code>:DISPlay:CONTrast?</code>
	Response (3 bytes + CRLF)	<code><Contrast></code> <ul style="list-style-type: none"> A multiple of 5 within the contrast setting range of {0 to 100} Returns the LCD contrast setting.
Description	Queries the LCD contrast setting.	
Example	<code>:DISPlay:CONTrast?</code> <code> 60</code> The LCD contrast setting is 60.	

Setting the LCD backlight		
Syntax	Command	<code>:DISPlay:BACKlight <Backlight></code> • Backlight {0 to 3} Sets the LCD backlight.
Description	Specifies the brightness of the LCD backlight. 0 can be set only through communications. When 0 is set, the LCD backlight turns off.	
Example	<code>:DISPlay:BACKlight 2</code> The LCD backlight setting is 2.	
Querying the LCD backlight		
Syntax	Query	<code>:DISPlay:BACKlight?</code>
	Response (1 byte + CRLF)	<code><Backlight></code> • Backlight {0 to 3} Returns the LCD backlight setting.
Description	Queries the brightness of the LCD backlight.	
Example	<code>:DISPlay:BACKlight?</code> 2 The LCD backlight setting is 2.	

Setting the power supply frequency		
Syntax	Command	<code>:SYSTem:LFrequency <Power supply frequency></code> • Power supply frequency {AUTO 50 60} Sets the power supply frequency.
Description	Specifies the power supply frequency. AUTO The power supply frequency (50 Hz or 60 Hz) is automatically detected at the time of startup. 50 The power supply frequency is set to 50 Hz. 60 The power supply frequency is set to 60 Hz.	
Example	<code>:SYSTem:LFrequency 60</code> The power supply frequency is set to 60 Hz.	
Querying the power supply frequency		
Syntax	Query	<code>:SYSTem:LFrequency?</code>
	Response (2 or 4 bytes + CRLF)	<code><Power supply frequency></code> • Power supply frequency {AUTO 50 60} Returns the power supply frequency setting.
Description	Queries the power supply frequency setting.	
Example	<code>:SYSTem:LFrequency?</code> 60 The power supply frequency setting is 60 Hz.	

Querying the automatically detected power supply frequency		
Syntax	Query	<code>:SYSTem:LFRequency:AUTO?</code>
	Response (2 or 5 bytes + CRLF)	<code><Power supply frequency></code> • Power supply frequency {ERROR 50 60} Returns the automatically detected power supply frequency setting.
Description	Queries the automatically detected power supply frequency. ERROR Detection of the power supply frequency has failed at the startup. 50 The power supply frequency has been detected as 50 Hz. 60 The power supply frequency has been detected as 60 Hz.	
Example	<code>:SYSTem:LFRequency:AUTO?</code> 60 The power supply frequency has been detected as 60 Hz.	

Setting the key lock state		
Syntax	Command	<code>:SYSTem:KLOCK {ON OFF}</code>
Description	Sets the key lock state.	
Example	<code>:SYSTem:KLOCK ON</code> The key is set to be locked.	
Querying the key lock state		
Syntax	Query	<code>:SYSTem:KLOCK?</code>
	Response (2 or 3 bytes + CRLF)	<code>{ON OFF}</code>
Description	Queries the key lock state.	
Example	<code>:SYSTem:KLOCK?</code> ON Key lock	

Setting the key lock passcode		
Syntax	Command	<p>:SYSTem:KLOCK:PASScode {ON OFF} [,<"Passcode">]</p> <ul style="list-style-type: none"> • {ON OFF} Sets the key lock passcode. • "Passcode" {up to 8 characters, including single-byte numerals (0 to 9), letters (a through z), and the underbar character (_)} Specifies the passcode. It is optional.
Description	Sets the key lock passcode. The passcode is enclosed in double quotation marks ("). The passcode is not changed if it is optional.	
Example	<p>:SYSTem:KLOCK:PASScode ON,"HIOKI"</p> <p>The key lock passcode setting is enabled and the passcode is set to "HIOKI".</p>	
Querying the key lock passcode		
Syntax	Query	:SYSTem:KLOCK:PASScode?
	Response (5 to 14 bytes + CRLF)	<p>{ON OFF},<"Passcode"></p> <p>{ON OFF} Returns the key lock passcode setting. "Passcode" {up to 8 characters, including single-byte numerals (0 to 9), letters (a through z), and the underbar character (_)} The passcode is returned.</p>
Description	Queries the key lock passcode.	
Example	<p>:SYSTem:KLOCK:PASScode? ON,"HIOKI"</p> <p>The key lock passcode setting is enabled and the passcode is "HIOKI".</p>	

Querying the EXT. I/O NPN/PNP switch status		
Syntax	Query	:IO:MODE?
	Response (3 bytes + CRLF)	<p><Switch status></p> <ul style="list-style-type: none"> • Switch status {NPN PNP} Returns the EXT. I/O NPN/PNP switch status.
Description	Queries the EXT. I/O NPN/PNP switch status.	
Example	<p>:IO:MODE? NPN</p> <p>The EXT. I/O NPN/PNP switch is set to NPN.</p>	

Querying the FPGA version number		
Syntax	Query	<p>:SYSTem:FPGA? [<Type>]</p> <ul style="list-style-type: none"> • FPGA type {MAIN SUB} Specifies the FPGA type. The FPGA version number is returned if the FPGA type is optional.
	Response (8 bytes + CRLF)	<p><FPGA version No.></p> <ul style="list-style-type: none"> • FPGA version number Returns the FPGA version number.
Description	Queries the FPGA version number. A response of 8 characters is returned.	
Example	<p>:SYSTem:FPGA? MAIN A1234567</p> <p>The main FPGA version number is A1234567.</p>	

Querying the adjustment date		
Syntax	Query	:SYSTem:ADJusted:DATE?
	Response (8 bytes + CRLF)	<Year>,<Month>,<Day> <hr/> <ul style="list-style-type: none"> • Year {0 to 99} Returns the last 2 digits of the year. • Month {1 to 12} Returns the month. • Day {1 to 31} Returns the day.
Description	Queries the final adjustment date.	
Example	:SYSTem:ADJusted:DATE? 21,05,23 The adjustment date is May 23, 2021.	

Querying the calibration date		
Syntax	Query	:SYSTem:CALibrated:DATE?
	Response (8 bytes + CRLF)	<Year>,<Month>,<Day> <hr/> <ul style="list-style-type: none"> • Year {0 to 99} Returns the last 2 digits of the year. • Month {1 to 12} Returns the month. • Day {1 to 31} Returns the day.
Description	Queries the final calibration date.	
Example	:SYSTem:CALibrated:DATE? 21,05,23 The calibration date is May 23, 2021.	

Changing the settings to the default settings (except for the communications settings)		
Syntax	Command	:SYSTem:RESet
Description	Sets the instrument to the default settings. The communications settings, however, are not changed. See "11.9 Default Setting" (p. 214)	
Example	:SYSTem:RESet Performs a system reset.	

RS-232C

Setting the RS-232C communications speed		
Syntax	Command	<code>:SYSTem:COMMunicate:RS232C:SPEed <Communications speed></code>
		<ul style="list-style-type: none"> Communications speed {9600 19200 38400 57600} Sets the communications speed.
Description	Specifies the RS-232C communications speed.	
Example	<code>:SYSTem:COMMunicate:RS232C:SPEed 19200</code> The RS-232C communications speed is set to 19200 bps.	
Querying the RS-232C communications speed		
Syntax	Query	<code>:SYSTem:COMMunicate:RS232C:SPEed?</code>
	Response (4 to 5 bytes + CRLF)	<code><Communications speed></code> <ul style="list-style-type: none"> Communications speed {9600 19200 38400 57600} Returns the communications speed setting.
Description	Queries the RS-232C communications speed.	
Example	<code>:SYSTem:COMMunicate:RS232C:SPEed? 19200</code> The RS-232C communications speed setting is 19200 bps.	

LAN

Setting the LAN IP address		
Syntax	Command	<p>:SYSTem:COMMunicate:LAN:IPAdDress <Number 1>,<Number 2>,<Number 3>,<Number 4></p> <hr/> <ul style="list-style-type: none"> Number 1,Number 2,Number 3,Number 4 {0 to 255} <p>Sets the IP address using 4 numbers.</p>
Description	<p>Sets the LAN IP address. The setting is enabled after :SYSTem:COMMunicate:LAN:UPDate is executed. The LAN stops when the IP address is set to 0.0.0.0. When connecting the instrument to an existing network, set the IP address via RS-232C or USB in advance. Using a wrong or duplicated IP address can cause a problem in the existing network.</p>	
Example	<p>:SYSTem:COMMunicate:LAN:IPAdDress 192,168,1,100 Sets the IP address to "192.168.1.100".</p>	
NOTICE	<p>The commands are delimited by commas.</p>	
Querying the LAN IP address		
Syntax	Query	:SYSTem:COMMunicate:LAN:IPAdDress?
	Response (7 to 15 bytes + CRLF)	<p><Number 1>,<Number 2>,<Number 3>,<Number 4></p> <hr/> <ul style="list-style-type: none"> Number 1,Number 2,Number 3,Number 4 {0 to 255} <p>Returns the IP address using 4 numbers.</p>
Description	<p>Queries the LAN IP address. When 0,0,0,0 is returned, the LAN is OFF.</p>	
Example	<p>:SYSTem:COMMunicate:LAN:IPAdDress? 192,168,1,100 The IP address has been set to 192.168.1.100.</p>	

Querying the LAN IP address to be enabled after confirmation of the LAN settings		
Syntax	Query	:SYSTem:COMMunicate:LAN:IPAdDress:PREParation?
	Response (7 to 15 bytes + CRLF)	<p><Number 1>,<Number 2>,<Number 3>,<Number 4></p> <hr/> <ul style="list-style-type: none"> Number 1,Number 2,Number 3,Number 4 {0 to 255} <p>Returns the subnet mask using 4 numbers.</p>
Description	<p>Queries the LAN IP address to be enabled after confirmation of the LAN settings. It is used to confirm the IP address set before the :SYSTem:COMMunicate:LAN:UPDate command is sent. The currently set IP address is returned if the command for setting the IP address is not sent.</p>	
Example	<p>:SYSTem:COMMunicate:LAN:IPAdDress:PREParation? 192,168,1,100 The LAN IP address to be enabled after confirmation of the LAN settings is 192.168.1.100.</p>	

Setting the LAN subnet mask		
Syntax	Command	<code>:SYSTem:COMMunicate:LAN:SMASk <Number 1>,<Number 2>,<Number 3>,<Number 4></code>
		<ul style="list-style-type: none"> Number 1,Number 2,Number 3,Number 4 {0 to 255} Sets the subnet mask using 4 numbers.
Description	Sets the subnet mask of LAN. The setting is enabled after <code>:SYSTem:COMMunicate:LAN:UPDate</code> is executed. When connecting the instrument to an existing network, set the IP address via RS-232C or USB in advance. Setting a wrong subnet mask can cause a problem in the existing network.	
Example	<code>:SYSTem:COMMunicate:LAN:SMASk 255,255,255,0</code> Sets the subnet mask to "255.255.255.0".	
NOTICE	The commands are delimited by commas.	
Querying the LAN subnet mask		
Syntax	Query	<code>:SYSTem:COMMunicate:LAN:SMASk?</code>
	Response (7 to 15 bytes + CRLF)	<code><Number 1>,<Number 2>,<Number 3>,<Number 4></code> <ul style="list-style-type: none"> Number 1,Number 2,Number 3,Number 4 {0 to 255} Returns the subnet mask using 4 numbers.
Description	Queries the LAN subnet mask.	
Example	<code>:SYSTem:COMMunicate:LAN:SMASk? 255,255,255,0</code> The subnet mask has been set to 255.255.255.0.	

Querying the LAN subnet mask to be enabled after confirmation of the LAN settings		
Syntax	Query	<code>:SYSTem:COMMunicate:LAN:SMASk:PREParation?</code>
	Response (7 to 15 bytes + CRLF)	<code><Number 1>,<Number 2>,<Number 3>,<Number 4></code> <ul style="list-style-type: none"> Number 1,Number 2,Number 3,Number 4 {0 to 255} Returns the subnet mask using 4 numbers.
Description	Queries the LAN subnet mask to be enabled after confirmation of the LAN settings. It is used to confirm the subnet mask set before the <code>:SYSTem:COMMunicate:LAN:UPDate</code> command is sent. The currently set subnet is returned if the command for setting the subnet mask is not sent.	
Example	<code>:SYSTem:COMMunicate:LAN:SMASk:PREParation? 255,255,255,0</code> The subnet mask to be enabled after confirmation of the LAN settings is 255.255.255.0.	

Setting the LAN default gateway		
Syntax	Command	<code>:SYSTem:COMMunicate:LAN:GATeway <Number 1>,<Number 2>,<Number 3>,<Number 4></code>
		<ul style="list-style-type: none"> Number 1,Number 2,Number 3,Number 4 {0 to 255} Sets the IP address of the default gateway using 4 numbers.
Description	Sets the LAN default gateway. The setting is enabled after <code>:SYSTem:COMMunicate:LAN:UPDate</code> is executed. The gateway is disabled if it is set to 0.0.0.0. When connecting the instrument to an existing network, set the IP address via RS-232C or USB in advance. Setting a wrong gateway can cause a problem in the existing network.	
Example	<code>:SYSTem:COMMunicate:LAN:GATeway 192,168,0,200</code> The IP address of the default gateway is set to 192.168.0.200.	
NOTICE	The commands are delimited by commas.	
Querying the LAN default gateway		
Syntax	Query	<code>:SYSTem:COMMunicate:LAN:GATeway?</code>
	Response (7 to 15 bytes + CRLF)	<code><Number 1>,<Number 2>,<Number 3>,<Number 4></code> <ul style="list-style-type: none"> Number 1,Number 2,Number 3,Number 4 {0 to 255} Returns the IP address of the default gateway using 4 numbers.
Description	Queries the LAN default gateway. When 0,0,0,0 is returned, the gateway is OFF.	
Example	<code>:SYSTem:COMMunicate:LAN:GATeway? 192,168,0,200</code> The IP address of the default gateway has been set to 192.168.0.200.	

Querying the LAN default gateway to be enabled after confirmation of the LAN settings		
Syntax	Query	<code>:SYSTem:COMMunicate:LAN:GATeway:PREParation?</code>
	Response (7 to 15 bytes + CRLF)	<code><Number 1>,<Number 2>,<Number 3>,<Number 4></code> <ul style="list-style-type: none"> Number 1,Number 2,Number 3,Number 4 {0 to 255} Returns the IP address of the default gateway using 4 numbers.
Description	Queries the LAN default gateway to be enabled after confirmation of the LAN settings. It is used to confirm the default gateway set before the <code>:SYSTem:COMMunicate:LAN:UPDate</code> command is sent. The currently set default gateway is returned if the command for setting the default gateway is not sent.	
Example	<code>:SYSTem:COMMunicate:LAN:GATeway:PREParation? 192,168,0,200</code> The default gateway to be enabled after confirmation of the LAN settings is 192.168.0.200.	

Setting the LAN port number		
Syntax	Command	<code>:SYSTem:COMMunicate:LAN:CONTrol <Port number></code>
		<ul style="list-style-type: none"> Port number {1 to 65535} Specifies the port number of communications commands.
Description	Sets the TCP/IP port number that accepts communications commands via LAN communications. The setting is enabled after <code>:SYSTem:COMMunicate:LAN:UPDate</code> is executed.	
Example	<code>:SYSTem:COMMunicate:LAN:CONTrol 23</code> The port number is set to 23.	
Querying the LAN port number		
Syntax	Query	<code>:SYSTem:COMMunicate:LAN:CONTrol?</code>
	Response (1 to 5 bytes + CRLF)	<code><Port number></code> <ul style="list-style-type: none"> Port number {1 to 65535} Returns the port number of the communications command.
Description	Queries the TCP/IP port number that accepts communications commands via LAN communications.	
Example	<code>:SYSTem:COMMunicate:LAN:CONTrol?</code> <code>23</code> The port number has been set to 23.	

Querying the LAN port number to be enabled after confirmation of the LAN settings		
Syntax	Query	<code>:SYSTem:COMMunicate:LAN:CONTrol:PREParation?</code>
	Response (1 to 5 bytes + CRLF)	<code><Port number></code> <ul style="list-style-type: none"> Port number {1 to 65535} Returns the port number of the communications command.
Description	Queries the LAN port number to be enabled after confirmation of the LAN settings. It is used to confirm the port number set before the <code>:SYSTem:COMMunicate:LAN:UPDate</code> command is sent. The currently set port number is returned if the command for setting the port number is not sent.	
Example	<code>:SYSTem:COMMunicate:LAN:CONTrol:PREParation?</code> <code>23</code> The port number to be set after confirmation of the LAN settings is 23.	

Confirming the LAN settings		
Syntax	Command	<code>:SYSTem:COMMunicate:LAN:UPDate</code>
Description	Updates the LAN settings. The connection during LAN communications is cut off.	
Example	<pre> :SYSTem:COMMunicate:LAN:IPAdDress 192,168,1,100 :SYSTem:COMMunicate:LAN:SMASk 255,255,255,0 :SYSTem:COMMunicate:LAN:GATeway 0,0,0,0 :SYSTem:COMMunicate:LAN:CONTRol 23 :SYSTem:COMMunicate:LAN:UPDate </pre> Sets the LAN IP address to 192.168.1.100, subnet mask to 255.255.255.0, default gateway to OFF, and port number to 23.	

Querying the MAC address		
Syntax	Query	<code>:SYSTem:COMMunicate:LAN:MAC?</code>
	Response (19 bytes + CRLF)	<MAC address> <hr/> • MAC address Returns the MAC address using a character string such as "00-01-67-00-00-00".
Description	Queries the MAC address of the instrument.	
Example	<pre> :SYSTem:COMMunicate:LAN:MAC? "00-01-67-00-00-00" </pre> The MAC address is 00-01-67-00-00-00.	

Communications settings

Setting the auto data output function																																																																																																																																																			
Syntax	Command	<p><code>:SYSTem:COMMunicate:DATAout <Interface>, <Output type></code></p> <p>• Interface {OFF RS232C USB LAN} Sets the interface to which data is automatically output.</p> <p>• Output type {TYPE1 TYPE2} Sets the data output format.</p>																																																																																																																																																	
Description	Specifies the interface to which data is automatically output at the completion of measurement as well as the output type.																																																																																																																																																		
TYPE1																																																																																																																																																			
The data number, resistance value, and judgment result are output.																																																																																																																																																			
<table border="1" style="width:100%; text-align:center; border-collapse: collapse;"> <tr> <td style="width:12.5%;">1</td><td style="width:12.5%;">2</td><td style="width:12.5%;">3</td><td style="width:12.5%;">4</td><td style="width:12.5%;"></td><td style="width:12.5%;">1</td><td style="width:12.5%;">2</td><td style="width:12.5%;">3</td><td style="width:12.5%;">4</td><td style="width:12.5%;"></td><td style="width:12.5%;">M</td><td style="width:12.5%;">o</td><td style="width:12.5%;">h</td><td style="width:12.5%;">m</td><td style="width:12.5%;"></td><td style="width:12.5%;"></td><td style="width:12.5%;">P</td><td style="width:12.5%;">A</td><td style="width:12.5%;">S</td><td style="width:12.5%;">S</td><td style="width:12.5%;"></td><td style="width:12.5%;">C</td><td style="width:12.5%;">R</td><td style="width:12.5%;">L</td><td style="width:12.5%;">F</td> </tr> <tr> <td colspan="4">Data number (5 bytes)</td> <td colspan="4">Blank Resistance (5 bytes)</td> <td colspan="4">Unit (4 bytes)</td> <td colspan="4">Result (6 bytes)</td> <td colspan="2">Terminator (2 bytes)</td> </tr> </table>			1	2	3	4		1	2	3	4		M	o	h	m			P	A	S	S		C	R	L	F	Data number (5 bytes)				Blank Resistance (5 bytes)				Unit (4 bytes)				Result (6 bytes)				Terminator (2 bytes)																																																																																																							
1	2	3	4		1	2	3	4		M	o	h	m			P	A	S	S		C	R	L	F																																																																																																																											
Data number (5 bytes)				Blank Resistance (5 bytes)				Unit (4 bytes)				Result (6 bytes)				Terminator (2 bytes)																																																																																																																																			
<table border="1" style="width:100%; text-align:center; border-collapse: collapse;"> <tr> <td style="width:12.5%;"></td><td style="width:12.5%;"></td><td style="width:12.5%;"></td><td style="width:12.5%;"></td><td style="width:12.5%;">1</td> <td style="width:12.5%;"></td><td style="width:12.5%;"></td><td style="width:12.5%;"></td><td style="width:12.5%;"></td><td style="width:12.5%;"></td> <td style="width:12.5%;"></td><td style="width:12.5%;"></td><td style="width:12.5%;"></td><td style="width:12.5%;"></td><td style="width:12.5%;"></td> <td style="width:12.5%;"></td><td style="width:12.5%;"></td><td style="width:12.5%;"></td><td style="width:12.5%;"></td><td style="width:12.5%;"></td><td style="width:12.5%;"></td> <td style="width:12.5%;"></td><td style="width:12.5%;"></td><td style="width:12.5%;"></td><td style="width:12.5%;"></td> </tr> <tr> <td colspan="5">Normal value</td> <td colspan="5">Invalid data (not measured)</td> <td colspan="5">Overrange</td> <td colspan="5">Under range</td> <td colspan="5">Contact check FAIL</td> <td colspan="5">Overheat error</td> <td colspan="5">Instrument error</td> <td colspan="5">No judgment</td> <td colspan="5">Within the judgment reference range</td> <td colspan="5">Upper limit value < Resistance value</td> <td colspan="5">Lower limit value > Resistance value</td> <td colspan="5">Judgment not possible</td> </tr> <tr> <td colspan="5">x x x x x</td> <td colspan="5">I N V A L</td> <td colspan="5">O . F .</td> <td colspan="5">U . F .</td> <td colspan="5">C . E R R</td> <td colspan="5">H . E R R</td> <td colspan="5">E R R O R</td> <td colspan="5">N O C O M P</td> <td colspan="5">P A S S</td> <td colspan="5">U F A I L</td> <td colspan="5">L F A I L</td> <td colspan="5">U L F A I L</td> </tr> </table>							1																					Normal value					Invalid data (not measured)					Overrange					Under range					Contact check FAIL					Overheat error					Instrument error					No judgment					Within the judgment reference range					Upper limit value < Resistance value					Lower limit value > Resistance value					Judgment not possible					x x x x x					I N V A L					O . F .					U . F .					C . E R R					H . E R R					E R R O R					N O C O M P					P A S S					U F A I L					L F A I L					U L F A I L				
				1																																																																																																																																															
Normal value					Invalid data (not measured)					Overrange					Under range					Contact check FAIL					Overheat error					Instrument error					No judgment					Within the judgment reference range					Upper limit value < Resistance value					Lower limit value > Resistance value					Judgment not possible																																																																																												
x x x x x					I N V A L					O . F .					U . F .					C . E R R					H . E R R					E R R O R					N O C O M P					P A S S					U F A I L					L F A I L					U L F A I L																																																																																												
<ul style="list-style-type: none"> • Returns to 1 after the value reaches 65535. • Returns to 1 when AUTO DATA OUT is set to OFF. 																																																																																																																																																			
<ul style="list-style-type: none"> • If the set upper and lower limit values are greater than the display range's upper limit value, and the measured value is [Over.F] (overflow) • If the set upper and lower limit values are less than the display range's lower limit value, and the measured value is [Under.F] (underflow) • When the BDD count is at least 1 while the comparator function and BDD judgment are enabled 																																																																																																																																																			
* Numerical format for measured values																																																																																																																																																			
<table border="1" style="width:100%; border-collapse: collapse;"> <thead> <tr> <th style="width:20%;">Range</th> <th style="width:80%;">Normal value</th> </tr> </thead> <tbody> <tr> <td>2 MΩ</td> <td style="text-align:center;">x . x x x</td> </tr> <tr> <td>20 MΩ</td> <td style="text-align:center;">x x . x x</td> </tr> <tr> <td>200 MΩ</td> <td style="text-align:center;">x x x . x</td> </tr> <tr> <td>2000 MΩ</td> <td style="text-align:center;">x x x x</td> </tr> <tr> <td>Auto</td> <td style="text-align:center;">x x x x x</td> </tr> </tbody> </table> <p style="text-align:center;">Numerical format for the confirmed range</p>			Range	Normal value	2 MΩ	x . x x x	20 MΩ	x x . x x	200 MΩ	x x x . x	2000 MΩ	x x x x	Auto	x x x x x																																																																																																																																					
Range	Normal value																																																																																																																																																		
2 MΩ	x . x x x																																																																																																																																																		
20 MΩ	x x . x x																																																																																																																																																		
200 MΩ	x x x . x																																																																																																																																																		
2000 MΩ	x x x x																																																																																																																																																		
Auto	x x x x x																																																																																																																																																		
TYPE2																																																																																																																																																			
Data is output in the format same as <code>:MEASure?</code> according to the <code>:MEASure:VALid?</code> setting. See the <code>:MEASure?</code> query for the format.																																																																																																																																																			

Setting the auto data output function					
Example	<pre> :SYSTem:COMMunicate:DATAout RS232C,TYPE1 :STARt :STOP #### 1 0.150 Mohm UFAIL :STARt :STOP #### 2 2.154 Mohm PASS </pre> <p>The resistance value of the 1st measurement is 0.150 MΩ and the judgment is UFAIL. The resistance value of the 2nd measurement is 2.154 Ω and the judgment is PASS.</p> <pre> :SYSTem:COMMunicate:DATAout RS232C,TYPE2 :MEASure:VALid 255 :STARt :STOP #### 33, 0,0.153E+06, UFAIL,+2.50038E+01,+1.62918E-04,99,PASS :STARt :STOP #### 33, 0,0.151E+06, UFAIL,+2.50038E+01,+1.65687E-04,99,PASS </pre>				
Querying the auto data output function					
Syntax	<table border="1"> <tr> <td style="vertical-align: top;">Query</td> <td>:SYSTem:COMMunicate:DATAout?</td> </tr> <tr> <td style="vertical-align: top;">Response (8 to 12 bytes + CRLF)</td> <td> <p><Interface>,<Output type></p> <hr/> <ul style="list-style-type: none"> Interface {OFF RS232C USB LAN} Returns the interface setting to be used for automatic data output. Output type {TYPE1 TYPE2} Returns the data output format. </td> </tr> </table>	Query	:SYSTem:COMMunicate:DATAout?	Response (8 to 12 bytes + CRLF)	<p><Interface>,<Output type></p> <hr/> <ul style="list-style-type: none"> Interface {OFF RS232C USB LAN} Returns the interface setting to be used for automatic data output. Output type {TYPE1 TYPE2} Returns the data output format.
Query	:SYSTem:COMMunicate:DATAout?				
Response (8 to 12 bytes + CRLF)	<p><Interface>,<Output type></p> <hr/> <ul style="list-style-type: none"> Interface {OFF RS232C USB LAN} Returns the interface setting to be used for automatic data output. Output type {TYPE1 TYPE2} Returns the data output format. 				
Description	Queries the interface to which data is automatically output and the data format.				
Example	<pre> :SYSTem:COMMunicate:DATAout? RS232C,TYPE1 </pre> <p>The interface to which data is automatically output is RS-232C and the data format is TYPE1.</p>				

Setting the command monitor function		
Syntax	Command	<code>:SYSTem:COMMunicate:MONitor {ON OFF}</code>
Description	Sets the command monitor function.	
Example	<code>:SYSTem:COMMunicate:MONitor ON</code> The command monitor function is set to be used.	
Querying the command monitor function		
Syntax	Query	<code>:SYSTem:COMMunicate:MONitor?</code>
	Response (2 or 3 bytes + CRLF)	<code>{ON OFF}</code>
Description	Queries the command monitor function setting.	
Example	<code>:SYSTem:COMMunicate:MONitor?</code> <code>ON</code> The command monitor function is to be used.	

Returning to the local state		
Syntax	Command	<code>:SYSTem:LOCal</code>
Description	Cancels the remote state via communications and returns to the local state. The key operation is enabled.	
Example	<code>:SYSTem:LOCal</code> The remote state is canceled.	

8.10 Communications Command Examples

Communications commands for controlling the instrument using the communications function are introduced here.

When a command is sent, a message terminator (CR, LF, etc.) needs to be added, however, it is omitted in this section. The terminator (CR+LF) added to responses is also omitted in the same manner.

Verification example before measurement

This is an example of checking the instrument status, acquiring the instrument information, etc. before measurement.

Description		Sent to the BT5525 from the controller	Example of the BT5525 response
(1)	Checking the communications status	<code>*IDN?</code>	<code>HIOKI, BT5525, 220612345, V1.00</code>
(2)	Checking the FPGA version	<code>:SYSTEM:FPGA?</code>	<code>A2206123</code>
(3)	Checking the adjustment date	<code>:SYSTEM:ADJUSTED:DATE?</code>	<code>22,06,01</code>
(4)	Checking the calibration date	<code>:SYSTEM:CALIBRATED:DATE?</code>	<code>22,06,01</code>
(5)	Checking the self-test	<code>*TST?</code>	<code>PASS</code>
(6)	Checking the error	<code>:SYSTEM:ERROR?</code>	<code>0, "No Error"</code>

- (1) Communications with the instrument is checked. The manufacturer and model of the unit that sends a response are fixed. The serial number consists of 9 digits and the first 4 digits represent the manufacturing year and month. In this example, "2206" indicates June 2022. When controlling multiple units of the instrument, refer to the serial number and check the connection destination is correct. The version number may change due to software upgrade.
- (2) The FPGA version is checked.
- (3), (4) The adjustment date and calibration date are checked.
- (5) Perform a self-check and check that the instrument passes the test. Repair is necessary if the instrument fails the test.
- (6) The error information is checked.
When the error number is not 0, refer to the error list and take appropriate measures. See "10.3 Error" (p.197).

Basic measurement example

The following is an example of setting the measurement conditions and acquiring the measurement result of a 3-second test.

Description		Sent to the BT5525 from the controller	Example of the BT5525 response
(1)	Set the test voltage to 150 V.	<code>:VOLTage 150</code>	–
(2)	Set the current limit value to 2 mA.	<code>:CHARge:LIMit 2E-3</code>	–
(3)	Set the range to 200 MΩ.	<code>:RANGe 200M</code>	–
(4)	Set the speed to 10 PLCs.	<code>:SPEed 10</code>	–
(5)	Check the measurement conditions.	<code>:VOLTage?;:CHARge:LIMit?;:RANGe?;:SPEEd?</code>	<code>150; 2.00E-03;200M; 10</code>
(6)	Set the test time to 3 seconds.	<code>:TIMer 3</code>	–
(7)	Starts a test.	<code>:START</code>	–
(8)	Acquire the measurement status. (Monitor status by periodically sending <code>:STATe?</code> .)	<code>:STATe?</code>	<code>1</code>
		<code>:STATe?</code>	<code>1</code>
		...	
		<code>:STATe?</code>	<code>2</code>
		<code>:STATe?</code>	<code>0</code>
(9)	Acquire the measured values.	<code>:MEASure?</code>	<code>201.3E+6</code>

- (1) to (4) Set the test voltage, measurement range, and so on before starting a test.
The measurement conditions are set in the order in which commands are received. Commands may be sent consecutively if they are within the input buffer capacity (1 KB).
- (5) Check the measurement conditions.
Multiple commands can be sent all together with them delimited by semicolons. Responses are also delimited by semicolons.
- (6) The test time is set to 3 seconds.
- (7) Send the `:START` command and start the test.
Since the test time is set to 3 seconds, the test stops after 3 seconds.
- (8) The test status can be queried with `:STATe?`.
1 or 2 is returned when the test is being performed and 0 is returned when the test is stopped.
- (9) Acquire the measured value after the test.

Example of acquiring the time stamp, measurement status, and measured value

The following is an example of acquiring the time stamp, measurement status, and measured value.

Description		Sent to the BT5525 from the controller	Example of the BT5525 response
(1)	Sets the response details of measured values.	<code>:MEASure:VALid 7</code>	–
(2)	Test start	<code>:START</code>	–
(3)	Acquiring the measured values	<code>:MEASure?</code>	<code>␣␣3245,␣0,␣1063E+06</code>

- (1) Set the response description so that the time stamp, measurement status, and measured value are returned. In this example, 7 is set as the logical sum of bit 0 ($2^0 = 1$) of the time stamp, bit 1 ($2^1 = 2$) of the measurement status, and bit 2 ($2^2 = 4$) of the measured resistance value. For the response settings, see the `:MEAS:VALid` command.
- (2) Start the test and perform measurement.
- (3) Send the `:MEASure?` query and acquire the measured value. The time stamp is displayed in milliseconds (ms). If the measurement status is 0, the measured value is normal. For more details of other measurement status values, see the `:MEASure?` query description.

Measurement example using auto data output

The following is an example of automatically outputting measurement data to the interface after measurement.

Description		Sent to the BT5525 from the controller	Example of the BT5525 response
(1)	Set to output data to the USB interface as TYPE2.	<code>:SYSTEM:COMMunicate :DATAout USB,TYPE2</code>	–
(2)	Sets the response details of measured values.	<code>:MEASure:VALid 55</code>	–
(3)	Start the test with the test time set to 4.5 seconds.	<code>:TIMer 4.5;:START</code>	–
(4)	After the test, a response is returned.	–	<code>␣␣4499,␣␣0,201.4E+06,+1.01717E+02,+5.05024E-07</code>

- (1) Set to automatically output the measurement result to the interface as the TYPE2 format after the measurement is completed. When the type is set to TYPE2, the measurement data is output in the format set by the `:MEASure:VALid` command.
- (2) Set the response description so that the time stamp, measurement status, resistance value, voltage value, and current value are returned. In this example, 55 is set as the logical sum of bit 0 ($2^0 = 1$) of the time stamp, bit 1 ($2^1 = 2$) of the measurement status, bit 2 ($2^2 = 4$) of the measured resistance value, bit 4 ($2^4 = 16$) of the voltage value, and bit 5 ($2^5 = 32$) of the current value.
- (3) Perform the test for 4.5 seconds.
- (4) Output the measured value after the test is complete. Receive with the controller.

Example of using a contact check

The following is an example setting and enabling the threshold value of the contact check.

Description		Sent to the BT5525 from the controller	Example of the BT5525 response
(1)	Set the judgment threshold value of the contact check.	<code>:CONtactcheck:CAPacitance:THReshold 0.5E-9</code>	–
(2)	Enable the contact check function.	<code>:CONtactcheck ON</code>	–
(3)	Test start	<code>:TIMer 2;:START</code>	–
(4)	Acquire the measurement status. (Monitor status by periodically sending <code>:STATe?</code> .)	<code>:STATe?</code>	1
		<code>:STATe?</code>	1
		...	
		<code>:STATe?</code>	2
		<code>:STATe?</code>	0
(5)	Query the contact check capacitance value.	<code>:CONtactcheck:CAPacitance?</code>	1.2E-09
(6)	Query the contact check result.	<code>:CONtactcheck:RESult?</code>	PASS

- (1) Set the PASS judgment threshold value of the contact check to 500 pF. The contact check threshold value can be set in the range between 0.1E-9 and 200E-9 (100 pF to 200 nF).
- (2) Enable the contact check function.
- (3) Perform the test for 2 seconds.
- (4) Query the test status and monitor until the test is complete.
- (5) After the test is complete, query the measured capacitance value of the contact check. 1.2 nF is returned.
- (6) Query the contact check result. PASS is returned since the result is over the setting, 500 pF.

Measurement example using the comparator

This is an example that a judgment is made in 5 seconds after a test starts, a beep sounds when the judgment is PASS, and then the test ends.

Description		Sent to the BT5525 from the controller	Example of the BT5525 response
(1)	Set the test time to 10 seconds.	<code>:TIMer 10</code>	–
(2)	Set the comparator upper/lower limit values.	<code>:COMParator:LIMit 20E6,10E6</code>	–
(3)	Set the comparator delay time to 5 seconds.	<code>:COMParator:DELay 5</code>	–
(4)	Set the comparator test mode.	<code>:COMParator:MODE PASSstop</code>	–
(5)	Set the comparator beep.	<code>:COMParator:BEEPer PASS</code>	–
(6)	Test start	<code>:START</code>	–

- (1) to (5) When (1) to (5) are set, the comparator judgment result is PASS if the measurement result is in the range of the upper/lower limit values between 10 MΩ and 20 MΩ. When these conditions are satisfied, a beep sounds, and the test ends. If the result is not within the upper/lower limit value range, the judgment is FAIL. The test continues and ends after 10 seconds.
- (2) Set the comparator lower limit value to 10 MΩ and the upper limit value to 20 MΩ for a PASS judgment.
- (3) Set to make a comparator judgment in 5 seconds after the test starts. For a DUT with capacitance, setting a delay time from the start of measurement to judgment allows a judgment to be made using the measured value after a transient response is stabilized.
- (4) to (5) Set to sound a beep and stop the test if the comparator judgment result is PASS.

Measurement example using the BDD function

This is an example of setting and using the BDD function.

Description		Sent to the BT5525 from the controller	Example of the BT5525 response
(1)	Enable the BDD judgment using the CC (charging) voltage.	<code>:BDD:CC:V ON</code>	–
(2)	Set the BDD judgment threshold value using the CC voltage to 2 V.	<code>:BDD:CC:V:THReshold 2</code>	–
(3)	Query the BDD judgment threshold value using the CC voltage.	<code>:BDD:CC:V:THReshold?</code>	<code>2.0</code>
(4)	Enable the BDD judgment using the CV (steady state) voltage.	<code>:BDD:CV:V ON</code>	–
(5)	Set the BDD judgment threshold value using the CV voltage to 0.5 V.	<code>:BDD:CV:V:THReshold 0.5</code>	–
(6)	Query the BDD judgment threshold value using the CV voltage.	<code>:BDD:CV:V:THReshold?</code>	<code>0.5</code>
(7)	Enable the BDD judgment using the CV (steady state) current.	<code>:BDD:CV:I ON</code>	–
(8)	Set the BDD judgment threshold value using the CV current to 10%.	<code>:BDD:CV:I:THReshold 10</code>	–
(9)	Query the BDD judgment threshold value using the CV current.	<code>:BDD:CV:I:THReshold?</code>	<code>10.0</code>
(10)	Enable the setting to end the test if the BDD count is 1 or more.	<code>:BDD:STOP ON</code>	–
(11)	Perform the test for 10 seconds.	<code>:TIMer 10;:START</code>	–
(12)	Query the number of BDD measured values saved in the memory.	<code>:BDD:COUNT?</code>	<code>3</code>
(13)	Query the BDD measured values saved in the memory.	<code>:BDD:MEMory? CRLF</code>	<code>237.130,CVI, 60.9 237.131,CVI, 54.9 249.600,CVV, 0.92</code>

- (1) (4) (7) Enable the BDD function at each measurement. CC (constant current) charging is performed until the test voltage is reached after measurement starts and a voltage fluctuation is detected. Once the test voltage is reached, measurement is performed using CV (constant voltage) and fluctuations of the voltage and current are both detected.
- (2) (5) (8) Set the BDD threshold value. A voltage fluctuation is set as a value (unit: V) and a current fluctuation is set as a rate (unit: %).
- (3) (6) (9) Query the BDD threshold value to check it.
- (10) Enable the setting to stop the test when the BDD count is 1 or more.
- (12) (13) Query the BDD measured value stored in the instrument's memory after the test completes. The BDD count is 3, indicating that the instrument detected two current fluctuations and one voltage fluctuation that exceeded the applicable thresholds value during CV operation. Voltage fluctuations are output as a value (unit: V), while current fluctuations are output as a ratio (unit: %).

Example of saving and loading the measurement conditions (panel saving and panel loading)

This is an example of saving multiple measurement conditions at once.

Description		Sent to the BT5525 from the controller	Example of the BT5525 response
(1)	Set the test voltage to 500V.	<code>:VOLTage 500</code>	–
(2)	Set the comparator upper/lower limit values.	<code>:COMParator:LIMit OFF,20E6</code>	–
(3)	Saving to panel 1	<code>*SAV 1</code>	–
(4)	Set the test voltage to 100V.	<code>:VOLTage 100</code>	–
(5)	Set the comparator upper/lower limit values.	<code>:COMParator:LIMit 30E6,25E6</code>	–
(6)	Saving to panel 2	<code>*SAV 2</code>	–
(7)	Loading panel 1	<code>*RCL 1</code>	–
(8)	Query the test voltage and comparator upper/lower limit values.	<code>:VOLTage?;</code> <code>:COMParator:LIMit?</code>	<code>500;</code> <code>OFF,20.00E+06</code>
(9)	Loading panel 2	<code>*RCL 2</code>	–
(10)	Query the test voltage and comparator upper/lower limit values.	<code>:VOLTage?;</code> <code>:COMParator:LIMit?</code>	<code>100;30.00E+06,25.00E+06</code>

- Multiple measurement conditions can be saved in the instrument and loaded. The areas of the instrument for storing the measurement conditions are called panels and up to 15 panels (panel 1 to panel 15) can be used for storage.
- For the save items, see “11.9 Default Setting” (p. 214).
- In this example, the test voltage of 500 V, the comparator upper limit OFF setting, and the lower limit of 20 MΩ are saved to panel 1. The test voltage of 100 V, the comparator upper limit of 30 MΩ, and the lower limit of 25 MΩ are saved to panel 2. The two panels are loaded in order and the settings are checked.

(1) to (3) Set the measurement conditions to be saved to panel 1 and save them to panel 1.

(4) to (6) Set the measurement conditions to be saved to panel 2 and save them to panel 2.

(7) to (8) Load the measurement conditions for panel 1 and check the conditions.

(9) to (10) Load the measurement conditions for panel 2 and check the conditions.

Examples of LAN communications settings

The following are examples of setting the IP address, port number, etc.

Description		Sent to the BT5525 from the controller	Example of the BT5525 response
(1)	Setting the IP address	<code>:SYSTem:COMMunicate:LAN:IPADdress 172,16,1,100</code>	–
(2)	Setting the subnet mask	<code>:SYSTem:COMMunicate:LAN:SMASk 255,255,255,0</code>	–
(3)	Setting the default gateway	<code>:SYSTem:COMMunicate:LAN:GATeway 172,16,1,1</code>	–
(4)	Setting the port number	<code>:SYSTem:COMMunicate:LAN:CONTRol 523</code>	–
(5)	Checking the IP address after making a change	<code>:SYSTem:COMMunicate:LAN:IPADdress: PREParation?</code>	172,16,1,100
(6)	Checking the subnet mask after making a change	<code>:SYSTem:COMMunicate:LAN:SMASk: PREParation?</code>	255,255,255,0
(7)	Checking the default gateway after making a change	<code>:SYSTem:COMMunicate:LAN:GATeway: PREParation?</code>	172,16,1,1
(8)	Checking the port number after making a change	<code>:SYSTem:COMMunicate:LAN:CONTRol: PREParation?</code>	523
(9)	Confirms the LAN settings. (LAN restart)	<code>:SYSTem:COMMunicate:LAN:UPDate</code>	–
(10)	Checking the IP address	<code>:SYSTem:COMMunicate:LAN:IPADdress?</code>	172,16,1,100
(11)	Checking the subnet mask	<code>:SYSTem:COMMunicate:LAN:SMASk?</code>	255,255,255,0
(12)	Checking the default gateway	<code>:SYSTem:COMMunicate:LAN:GATeway?</code>	172,16,1,1
(13)	Checking the port number	<code>:SYSTem:COMMunicate:LAN:CONTRol?</code>	523

- Set the LAN using a communications command. If LAN communications cannot be established using the default IP address, make settings via RS-232C or USB communications.
- Note that the numerical values of the IP address and subnet mask are delimited by commas (,).

(1) to (4) Make necessary settings such as the IP address, port number, etc., for LAN connection.
The LAN settings are not reflected at this point.

(5) to (8) Check the IP address and port number after making a change.

(9) Update the LAN settings.
Since the communications is cut off when LAN is selected, establish a connection using the IP address and port number after a change is made again.

(10) to (13) Check the LAN settings after making a change.

Example of checking that commands are properly processed

This is an example of checking that commands sent from the controller to the instrument are properly processed.

Description		Sent to the BT5525 from the controller	Example of the BT5525 response
(1)	Clears the Event Status Register.	<code>*CLS</code>	–
(2)	Set the test voltage to 100 V.	<code>:VOLTage 100</code>	–
(3)	Check the test voltage.	<code>:VOLTage?</code>	100
(4)	Checking the Standard Event Status Register	<code>*ESR?</code>	0
(5)	Checking the error	<code>:SYSTem:ERRor?</code>	0, "No Error"
(6)	Error during an attempt to set the test voltage to 1000 V	<code>:VOLTage 1000</code>	–
(7)	Checking the Standard Event Status Register	<code>*ESR?</code>	16
(8)	Checking the Standard Event Status Register (2nd time)	<code>*ESR?</code>	0
(9)	Checking the error number	<code>:SYSTem:ERRor?</code>	-220, "Parameter error"
(10)	Checking the error number (2nd time)	<code>:SYSTem:ERRor?</code>	0, "No Error"

You can check for any error in command processing by referring to the EXE bit and CME bit of the Standard Event Status Register.

- (1) Clear the Event Status Register first.
- (2) to (3) This example sets the test voltage and verifies that the query responses are of the set voltage.
- (4) Since the commands are processed properly, the value of the Standard Event Status Register is also 0.
- (5) The error number is also 0 (No Error).
- (6) Specify a parameter outside the range for the command for setting the test voltage and cause an error to occur.
- (7) As the parameter is invalid, you can check that bit 4 (EXE) of the Standard Event Status Register is set and an execution error occurs.
- (8) When the `*ESR?` query is sent, the Standard Event Status Register is cleared. When the `*ESR?` query is sent again, 0 is returned.
- (9) The error number is -220 (Parameter error).
- (10) When the `:SYSTem:ERRor?` query is sent, the error number is also cleared. When the `:SYSTem:ERRor?` query is sent again, 0 (No Error) is returned.

9

Specifications

9.1 General specifications

Operating environment	Indoor use, pollution degree 2, altitude up to 2000 m (6562 ft.)	
Operating temperature and humidity range	0°C to 40°C (32°F to 104°F), 80% RH or less (non-condensing)	
Storage temperature and humidity range	-10°C to 50°C (14°F to 122°F), 80% RH or less (non-condensing)	
Standards	Safety	EN 61010
	EMC	EN 61326 Class A
Power supply	Rated supply voltage	100 V AC to 240 V (Assuming voltage fluctuation of ±10%)
	Rated power-supply frequency	50 Hz/60 Hz
	Anticipated transient overvoltage	2500 V
	Maximum rated power	100 VA
Continuous operating time	No defined (Continuous short circuit is not acceptable.)	
Interfaces (Standard equipment)	USB LAN RS-232C	
Dimensions	Approx. 215W × 80H × 306.5D mm (8.46"W × 3.15"H × 12.07"D) (excluding protruding parts)	
Weight	Approx. 2.8 kg (98.8 oz.)	
Product warranty duration	3 years	
Included accessories	See p. 8	
Options	See p. 9	

9.2 Input, Output, and Measurement Specifications

Basic specifications

Measurement items	Insulation resistance Voltage monitor		
Output generation	Output voltage range	25 V to 500 V (Default setting: 25 V)	
	Output setting resolution	1 V	
	Rated load	1.25 VA (500 V, 2.5 mA)	
	Short circuit current	60 mA or less	
	Output impedance	5 Ω (current limit setting 50 μA to 990 μA) 200 Ω (current limit setting 1.0 mA to 50 mA)	
	Analog output range	0 V to 4 V is output in all the ranges of the measured resistance. (Load resistance of 1 MΩ or more)	
	Constraints	When using a current limit setting of 5.1 mA or more, measurement will be forcibly stopped (Overheat error) if the voltage is not at least 20 V as of 200 ms after the start of measurement. Measurement will be possible after 1 s.	
		Resistance range	Resistance value range Output voltage (DC)
		2 MΩ	0.000 MΩ to 9.999 MΩ 0 V to 4 V
		20 MΩ	0.00 MΩ to 99.99 MΩ 0 V to 4 V
		200 MΩ	0.0 MΩ to 999.9 MΩ 0 V to 4 V
		2000 MΩ (100 V ≤ V ≤ 500 V)	0 MΩ to 9999 MΩ 0 V to 4 V
		Total resistance range	Over.F 4 V
			Under.F 0 V
Resistance measurement	Resistance range composition: 2 MΩ, 20 MΩ, 200 MΩ, 2000 MΩ (With auto/hold settings)		
	Set voltage	Resistance range	Display range Resolution
	25 V ≤ V < 100 V	2 MΩ	0.050 MΩ to 9.999 MΩ 0.001 MΩ
		20 MΩ	1.80 MΩ to 99.99 MΩ 0.01 MΩ
		200 MΩ	18.0 MΩ to 999.9 MΩ 0.1 MΩ
	100 V ≤ V ≤ 500 V	2 MΩ	0.200 MΩ to 9.999 MΩ 0.001 MΩ
		20 MΩ	1.00 MΩ to 99.99 MΩ 0.01 MΩ
		200 MΩ	10.0 MΩ to 999.9 MΩ 0.1 MΩ
		2000 MΩ	100 MΩ to 9999 MΩ 1 MΩ
	When the display range is exceeded, [Over.F] or [Under.F] is displayed on the screen.		
Display update speed	1 PLC		
Test time	Setting range	0.050 s to 999.999 s (when the test time function is enabled)	
	Set resolution	1 ms	
Comparator delay time	Setting range	AUTO or 0.001 s to 999.999 s	
	Set resolution	1 ms	
	Operation	Comparator judgment is not performed until the response time has elapsed after the start of measurement. The timer counts up along with the test time.	

Accuracy Specifications

Accuracy guarantee conditions	Accuracy guarantee conditions	1 year
	Accuracy guarantee temperature and humidity range	23°C ±5°C (73°F ±9°F), 80% RH or less
	Temperature coefficient	0.1 × Standard accuracy × (T – 23) added T: Operating temperature (°C) (23°C ±5°C is not added to the standard accuracy.)
	Warm-up time	15 minutes or longer
	Power supply frequency range	50 Hz ±2 Hz, 60 Hz ±2 Hz

Output generation accuracy	Output voltage accuracy	± (1% of setting ±2 V) without load
	Voltage monitor accuracy	2% of reading of output voltage +1 V
	Analog output accuracy	±2% f.s.

Resistance measurement accuracy	Setting range	Resistance Range	Accuracy guarantee range	Basic specifications
	25 V ≤ V < 100 V	2 MΩ	0.050 MΩ to 2.000 MΩ	±1.5% rdg ±2 dgt
			2.001 MΩ to 9.999 MΩ	±15% rdg
		20 MΩ	1.80 MΩ to 20.00 MΩ	±1.5% rdg ±2 dgt
			20.01 MΩ to 99.99 MΩ	±5% rdg
		200 MΩ	18.0 MΩ to 200.0 MΩ	±2.5% rdg
			200.1 MΩ to 999.9 MΩ	±5% rdg
	100 V ≤ V ≤ 500 V	2 MΩ	0.200 MΩ to 2.000 MΩ	±1.5% rdg ±2 dgt
			2.001 MΩ to 9.999 MΩ	±10% rdg
		20 MΩ	1.00 MΩ to 20.00 MΩ	±1.5% rdg ±2 dgt
			20.01 MΩ to 99.99 MΩ	±15% rdg
		200 MΩ	10.0 MΩ to 200.0 MΩ	±2.5% rdg
			200.1 MΩ to 999.9 MΩ	±5% rdg
2000 MΩ	100 MΩ to 2000 MΩ	±2.5% rdg		
	2001 MΩ to 9999 MΩ	±5% rdg		

Test time accuracy	Accuracy guarantee range	0.050 s (50 ms) to 999.999 s	
	Test time accuracy	±0.005 s	(0.050 s to 0.099 s of set range)
		±0.05 s	(0.100 s to 9.999 s of set range)
		±0.5 s	(10.000 s to 999.999 s of set range)

Functional specifications

(1) Contact check function

Detection method	Two-terminal electrostatic capacitance measurement method
Operation	Executed one time before measurement starts (before output voltage is applied).
Detection signal	Sine wave having a frequency of either 437 Hz or 3496 Hz and a peak-to-peak voltage of 300 mV
Capacitance measurable range	100 pF to 200 nF
Capacitance measurement accuracy range	1 nF to 100 nF
Capacitance measurement accuracy	Within a range of 35% of reading plus 0.1 nF in either direction
Judgment reference value setting range	100 pF to 100 nF
Judgment	PASS: Capacitance measured value \geq Judgment reference value FAIL: Judgment reference value $>$ Capacitance measured value

See "5.1 Checking for Any Contact Defects and Confirming Contact Condition (Contact Check Function)" (p. 58).

(2) Current limit function

Setting range	50 μ A to 50 mA	
Set resolution	50 μ A to 990 μ A:	10 μ A
	1.0 mA to 50.0 mA:	0.1 mA
Output accuracy	Within a range of 20% of setting plus 10 μ A in either direction	
Functional specifications	MANUAL	Limits current to the set value.
	AUTO	Current limit values are set automatically based on the desired DUT charging time and the DUT's capacitance. (Current limit values are not covered by the accuracy guarantee.)
Constraints	Current is limited to the following setting values once the voltage reaches set value:	
	50 μ A to 5.0 mA:	Set value
	5.1 mA to 50.0 mA:	5 mA

See "5.3 Limiting the Current to Be Applied to the Device Under Test (DUT)" (p. 64).

(3) Break Down Detect (BDD) function

Operations	Charging (CC)	Determines any variable voltage value as a judgment value. When the measured value exceeds the judgment value range, a FAIL judgment is given.
	Steady state (CV)	Determines a judgment value as a percentage (%) of the set voltage value and current value. When the measured value exceeds the judgment value range, a FAIL judgment is given.
Judgment value range	Charging (CC V)	0.1 V to 500.0 V
	Steady state (CV V)	0.1 V to 500.0 V
	Steady state (CV I)	0.6% to 999.9%

See "5.2 Detecting Micro Insulation Failure (BDD Function)" (p. 60).

(4) Comparator function

Settings	Use the F3 key [COMP] on the main unit to make settings. The function can be set using the resistance upper limit value and lower limit value. The set value is optional.	
Judgment	UPPER_FAIL	Measured value > Upper limit
	PASS	Lower limit ≤ Measured value ≤ Upper limit
	LOWER_FAIL	Measured value < Lower limit
	UL_FAIL	Judgment is not possible, or BDD judgment is enabled and the BDD count is 1 or greater
Beep	ON/OFF (based on the judgment beep setting)	
Judgment output	Based on the test mode When a UL_FAIL judgment is given, both the UPPER_FAIL and LOWER_FAIL signals are output. The final test result is retained.	

See “3.6 Judging the Measured Value (Comparator Function)” (p. 44).

(5) Panel function

Settings	Use the MENU key on the main unit to make settings.
Save and delete	Enabled
Number of panels	Up to 15 panels (can be saved or loaded)

See “6.1 Saving Measurement Conditions (Panel Save Function)” (p. 78) and
“6.2 Loading Measurement Conditions (Panel Load Function)” (p. 79).

(6) Memory function

Settings	No
Number of measured values that can be saved in the memory	999 measured values

See “4.4 Memory Function” (p. 53).

(7) Sampling time

Setting range	1 PLC to 100 PLCs
----------------------	-------------------

See “3.3 Setting the Sampling Time” (p. 38).

(8) Measurement delay time

Setting range	1 PLC to 100 PLCs
----------------------	-------------------

See “3.4 Setting the Measurement Delay Time” (p. 39).

(9) Test mode

Mode description	Continuous test	Measures for the set test time, makes a judgment for each measurement, outputs the judgment result, and shuts down the output voltage. The displayed measured value and judgment result at the completion of measurement are retained.
	PASS STOP	Ends the test when a PASS judgment is made and shuts down the output voltage. The displayed measured value and PASS display at the completion of measurement are retained.
	FAIL STOP	Ends the test when a FAIL judgment is made and shuts down the output voltage. The displayed measured value and FAIL display at the completion of measurement are retained.
	The beep is based on the judgment beep setting.	

See “3.7 Setting the Test Mode” (p. 46)

(10) Judgment beep

Operations	PASS	A beep sounds when a PASS judgment is made.
	FAIL	A beep sounds when a FAIL judgment is made.
	END	A beep sounds when a test ends.
	OFF	A beep does not sound.

See “3.8 Notifying the Judgment Result and Test Completion with a Beep” (p. 47)

(11) Key operation sound

Operations	ON/OFF setting can be switched.
-------------------	---------------------------------

See “5.4 Setting Whether to Turn ON or OFF the Key Operation Sound” (p. 67)

(12) Interlock function

Operations	Output is shut down in synchronization with the external equipment to ensure the safety of the operator.
Operation mode	Always ON

See “2.6 Shutting Down the Output of the Instrument (Interlock Function)” (p. 32)

(13) Key lock function

Operations	The function is enabled when the F4 key [LOCK] on the main unit is pressed.
Unlock method	Press the UNLOCK key for at least 1 second.

See “5.5 Enabling/Disabling the Key Operations” (p. 68)

(14) Automatic discharge function

Operations	The DUT is discharged at 40 mA or more after measurement is completed.
-------------------	--

See “4.6 Discharging Residual Electric Charge (Auto Discharge Function)” (p. 56)

(15) System reset function

Operations	All measurement conditions and panel data are initialized to the factory settings.
-------------------	--

See “5.9 Initializing the Instrument (Reset)” (p. 75)

(16) Command monitor function

Operations	Communications commands and query responses are displayed on the screen.
-------------------	--

Settings	Use the MENU key on the main unit to set ON/OFF.
-----------------	---

See “8.6 Communications Command Display (Command Monitor Function)” (p. 112)

(17) Automatic data output function

Operations	Select from the following. OFF: Data is not output. TYPE1: The measured value and judgment result are output. TYPE2: The measured value (exponent display 000.0E + 06) is displayed. Interface: The operations are based on the interface settings.
-------------------	---

See “8.5 Automatically Sending the Measured Value Every Time a Test Is Completed (Auto Data Output Function)” (p. 111)

Interface specifications

(1) USB

Electrical specifications	USB2.0 (Full-Speed)	
Connector	Series B receptacle	
Class	CDC class (USB COM)	
Delimiter	When sending	CR+LF
	When receiving	CR, LF, CR+LF

See "8.4 USB Interface" (p. 110)

(2) LAN

Standards	IEEE 802.3	
Transmission method	100BASE-TX Full duplex	
Protocol	TCP/IP	
Connector	RJ-45	
Communications description	Configuring settings and acquiring measured values using communications commands	
Settings	IP address, subnet mask, default gateway Communications command port number (1 to 65535)	
Default setting	IP address	192.168.1.1
	Subnet mask	255.255.0.0
	Default gateway	0.0.0.0 (None)
	Communications command port	23
Delimiter	When sending	CR+LF
	When receiving	CR, LF, CR+LF

See "8.3 LAN Interface" (p. 103)

(3) RS-232C

Transmission method	Communications method	Full duplex
	Synchronization method	Start/stop synchronization
Communications speed	9600 bps (default setting)	
	19200 bps	
	38400 bps	
	57600 bps	
Data length	8 bits	
Parity	None	
Stop bit	1 bit	
Message terminator (Delimiter)	When sending	CR+LF
	When receiving	CR, LF, CR+LF
Flow control	None	
Electrical specifications	Input voltage level	
	5 V to 15 V	ON
	-15 V to -5 V	OFF
	Output voltage level	
	5 V to 9 V	ON
	-9 V to -5 V	OFF

See "8.2 RS-232C Interface" (p. 101)

(4) EXT. I/O**Electrical specifications**

Connector used	D-sub 37-pin female, #4-40 locking screw	
Input	Photocoupler-isolated no-voltage contact input (current sink/source output compatible)	
	Input ON voltage	Residual voltage 1 V or less
	Input OFF voltage	OPEN (interrupting current 100 μ A or less)
	Input ON current	3 mA/Channel
	Maximum applied voltage	30 V
Output	Photocoupler-isolated open-drain output (non-polar)	
	Maximum load voltage	30 V
	Residual voltage	1 V or less
	Maximum output current	50 mA/Channel
Power output	Output voltage	Sink output: 5.0 V \pm 10% Source output: -5.0 V \pm 10%
	Maximum output current	100 mA
	Isolation	Protective ground potential and isolated measurement circuit
	Line-to-earth voltage	50 V DC, 30 V rms AC, 42.4 V peak AC or less

See "7 External Control (EXT. I/O)" (p. 83)

Pin arrangement

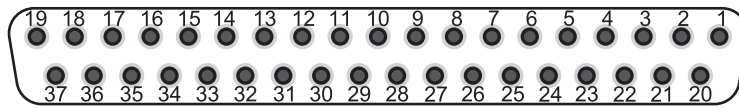

Pin	Signal name	I/O	Function	Logic
1	START	IN	Measurement start	Edge
2		–	–	–
3	INTERLOCK	IN	Cancellation of interlock state	Level
4	LOAD1	IN	Panel number selection	Level
5	LOAD3	IN	Panel number selection	Level
6	LOAD_VALID	IN	Execute panel load	Edge
7		–	–	–
8	ISO_5V	–	Isolated power supply ± 5 V output	–
9	ISO_COM	–	Isolated power supply common	–
10	SYSTEM_ERR	OUT	Main unit error	Level
11	UPPER FAIL	OUT	Comparator judgment	Level
12	LOWER FAIL	OUT	Comparator judgment	Level
13	BDD	OUT	BDD result	Level
14		–	–	–
15		–	–	–
16		–	–	–
17		–	–	–
18		–	–	–
19		–	–	–
20	STOP	IN	Measurement end	Edge
21		–	–	–
22	LOAD0	IN	Panel number selection	Level
23	LOAD2	IN	Panel number selection	Level
24		–	–	–
25		–	–	–
26		–	–	–
27	ISO_COM	–	Isolated power supply common	–
28	TEST	OUT	From measurement start to discharge end	Level
29	C_CHECK_FAIL	OUT	Contact check judgment	Level
30	PASS	OUT	Comparator judgment	Level
31	VON	OUT	The voltage monitor value is within 10% of the set voltage value.	Level
32		–	–	–
33		–	–	–
34		–	–	–
35		–	–	–
36		–	–	–
37		–	–	–

The input signals to the instrument are indicated as IN and the output signals as OUT in the table above.

Other Specifications

Contrast adjustment	Adjustment range	0 to 100 (Resolution: 5)
Backlight	Setting range	0: OFF (0 can be set only using a communications command.) 1: Dark 2: Standard 3: Bright
	Lifetime	100000 hours
Indicator	Display	TEST PASS U. FAIL L. FAIL

9.3 Specifications of the Options

L2130 Clip Type Lead

Operating environment	Indoor use, pollution degree 2, altitude up to 2000 m (6562 ft.)
Operating temperature and humidity range	0°C to 40°C (32°F to 104°F), 80% RH or less (non-condensing)
Storage temperature and humidity range	-10°C to 50°C (14°F to 122°F), 80% RH or less (non-condensing)
Standards	EN 61010 Type A
Length	Overall length: Approx. 1710 mm (67.32") Cable length: Approx. 1500 mm (59.06")
Weight	Approx. 70 g (2.5 oz.)
Product warranty duration	None (not eligible)
Rated current	50 mA
Rated voltage between input terminal and ground	500 V (anticipated transient overvoltage: 50 V)

L2131 Clip Type Lead

Operating environment	Indoor use, pollution degree 2, altitude up to 2000 m (6562 ft.)
Operating temperature and humidity range	0°C to 40°C (32°F to 104°F), 80% RH or less (non-condensing)
Storage temperature and humidity range	-10°C to 50°C (14°F to 122°F), 80% RH or less (non-condensing)
Standards	EN 61010 Type A
Length	Overall length: Approx. 1675 mm (65.94") Cable length: Approx. 1500 mm (59.06")
Weight	Approx. 170 g (6.0 oz.)
Product warranty duration	None (not eligible)
Rated current	50 mA
Insulation resistance	10 GΩ (between the main electrode and internal shield at 500 V DC)
Rated voltage between input terminal and ground	500 V (anticipated transient overvoltage: 50 V)

L2132 Unterminated Lead

Operating environment	Indoor use, pollution degree 2, altitude up to 2000 m (6562 ft.)
Operating temperature and humidity range	0°C to 40°C (32°F to 104°F), 80% RH or less (non-condensing)
Storage temperature and humidity range	-10°C to 50°C (14°F to 122°F), 80% RH or less (non-condensing)
Length	Overall length: Approx. 5075 mm (199.80") Cable length: Approx. 5000 mm (196.85")
Weight	Approx. 115 g (4.1 oz.)
Product warranty duration	None (not eligible)
Rated current	50 mA
Rated voltage between input terminal and ground	500 V (anticipated transient overvoltage: 50 V)

L2133 Unterminated Lead

Operating environment	Indoor use, pollution degree 2, altitude up to 2000 m (6562 ft.)
Operating temperature and humidity range	0°C to 40°C (32°F to 104°F), 80% RH or less (non-condensing)
Storage temperature and humidity range	-10°C to 50°C (14°F to 122°F), 80% RH or less (non-condensing)
Length	Overall length: Approx. 5050 mm (198.82") Cable length: Approx. 5000 mm (196.85")
Weight	Approx. 400 g (14.1 oz.)
Product warranty duration	None (not eligible)
Rated current	50 mA
Insulation resistance	10 GΩ (between the main electrode and internal shield at 500 V DC)
Rated voltage between input terminal and ground	500 V (anticipated transient overvoltage: 50 V)

L9094 Output Cord

Operating environment	Indoor use, pollution degree 2, altitude up to 2000 m (6562 ft.)
Operating temperature and humidity range	-25°C to 65°C (-13°F to 149°F), 80% RH or less (non-condensing)
Storage temperature and humidity range	-25°C to 65°C (-13°F to 149°F), 80% RH or less (non-condensing)
Maximum rated voltage	30 V
Maximum rated current	0.5 A
Cable to be used	30/0.08 XLPE55-SV K-M (Oki Electric Cable Co., Ltd.)
Length	Approx. 1500 mm (59.06") (connection terminal included)
Terminal shape	φ 3.5 mono plug Banana plug (red and black) Exposed type
Weight	Approx. 40 g (1.4 oz.)
Product warranty duration	None (not eligible)
Measurable frequency range	DC to 100 kHz
Terminal and cable connection	φ 3.5 mono plug tip - Coaxial center conductor - Banana plug (red) φ 3.5 mono plug base - Coaxial shielded cable - Banana plug (black)

L9637 RS-232C Cable

Operating environment	Indoor use, pollution degree 2, altitude up to 2000 m (6562 ft.)
Operating temperature and humidity range	0°C to 40°C (32°F to 104°F), 80% RH or less (non-condensing)
Storage temperature and humidity range	-10°C to 50°C (14°F to 122°F), 80% RH or less (non-condensing)
Length	Approx. 3000 mm (118.11") (including connector)
Weight	Approx. 215.4 g (7.6 oz.)
Product warranty duration	None (not eligible)
Connector	D-sub 9-pin female to D-sub 9-pin female

Cable

Cross cable

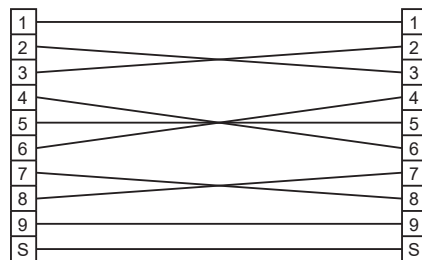

S: Shield

10 Maintenance and Service

10.1 Repairs, Inspections, and Cleaning

WARNING



- **Do not attempt to modify, disassemble, or repair the instrument yourself.**

There are some areas inside of the instrument where high voltage is present. These areas may expose the operator to electric shock or cause fire.

CAUTION



- **Observe the following when shipping the instrument.**

- Remove test leads from the instrument.
- Attach a description of the malfunction.
- Use the packaging in which the instrument was initially delivered and then pack that in an additional box.

Failure to do so could cause damage during shipment.

Calibration

The calibration period varies with the conditions and environment of use. It is recommended to determine a calibration period based on those factors and to have the instrument regularly calibrated by Hioki. Please contact your Hioki distributor to have your instrument periodically calibrated.

Backing up data

When repairing or calibrating the instrument, we may initialize it or update it to the latest software version. It is recommended to record the measurement conditions and system settings before requesting a repair.

Replaceable parts and service lives

Some parts used in the instrument are characterized by performance that degrades over years of use.

It is recommended to replace these parts regularly to ensure instrument functionality over the long term.

To order replacements, please contact your Hioki distributor.

Part service life varies with the operating environment and frequency of use.

These parts are not guaranteed to operate throughout the period defined by the recommended replacement interval.

Part name	Recommended replacement cycle	Remarks and conditions
Electrolytic capacitor	About 10 years	Requires replacement of the printed circuit boards on which such parts are mounted.
LCD backlight	About 10 years	If the LCD backlight is used 24 hours a day for 365 days.
Fan motor	About 8 years	If the fan motor is used 24 hours a day for 365 days.

Cleaning

CAUTION

- **Periodically clean the vents to avoid blockage.**

When the vents get clogged, the internal cooling effect of the instrument is hampered, and this can lead to damage to the instrument.



- **If the instrument becomes dirty, wipe the instrument clean with a soft cloth moistened with water or a neutral detergent.**

Never use solvents such as benzene, alcohol, acetone, ether, ketone, thinners or gasoline. Doing so could deform and discolor the instrument.

Wipe the LCD gently with a soft, dry cloth.

Disposal

Dispose of the instrument in accordance with local regulations.

10.2 Troubleshooting

If damage is suspected, read the “Before requesting repair” section to remedy the problem. If this does not help you, contact your authorized Hioki distributor or reseller.

When an error is displayed on the LCD screen, repair is necessary.

See “10.3 Error” (p.197)

For command, execution, and parameter errors during a test, only a buzzer sounds without any message.

When the cause is unknown

When the cause is unknown, reset the system.

All the settings are restored to the default settings at the time of shipment.

See “5.9 Initializing the Instrument (Reset)” (p.75)

Before requesting repair

Measurement

Symptom	Cause	Solution	Reference
The measured value does not appear.	• The auto range is not confirmed.	• Set a longer test time.	p.40
	• A long sampling time is set.	• Set a shorter sampling time.	p.38
The voltage is not output.	• The test lead is broken.	• Check the continuity of the test lead using a tester.	–
The set voltage is not output.	• The current limit function limits the current flowing through the DUT.	<ul style="list-style-type: none"> • Check the resistance value of the load and set an appropriate current limit value. • Example: When the current limit value is set to 0.5 mA, the set voltage to 500 V, and the resistance load to 400 kΩ, the voltage only goes up to 200 V. 	p.64
The measured value is not stable.	• The power supply frequency setting is not correct.	• Change the power supply frequency to a setting appropriate for the customer’s environment.	p.74
	• A load with an electrostatic capacitance is connected.	• It takes time for the measured value to be stabilized depending on the electrostatic capacitance. Set a longer test time.	p.40
	• The measured value is affected by noise.	• Review the test environment so that the measured value is not affected.	p.205
[U. FAIL] and [L. FAIL] light up at the same time.	• The range setting does not match the set comparator upper/lower limit values.	• Set the comparator upper/lower limit values according to the display range of the set range.	p.44
	• BDD judgment is enabled.	• A BDD count of 1 or greater results in a U. FAIL and L. FAIL judgment. Disable BDD judgment if this functionality is not necessary.	p.63

Communications and external control

Symptom	Cause	Solution	Reference
Communications cannot be performed properly.	• The RS-232C communications speed is not appropriate.	• Set the same communications speed for the controller and the instrument.	p.101
	• The IP address is not appropriate.	• Check that the IP address does not overlap with that of other network instruments. The initial IP address for the instrument is "192.168.1.1".	p.104
	• The COM port number used for USB communications is not appropriate.	• Check the COM port number. It can be checked in the Windows® device manager.	p.110
	• The sent commands are not appropriate.	• Use the command monitor function to check the commands that have been sent and received. • The locations where command and execution errors occur can also be checked.	p.112
A buzzer sounds when a command is sent.	• An error occurs during a communications command process.	• See the error display and troubleshooting.	p.197
The instrument cannot be controlled using the EXT. I/O.	• The connector is off. • The pin number is not correct. • The ISO_COM terminal wiring is not correct. • The NPN/PNP setting is not correct.	• Perform contact (or open collector) control. (Not controlled by voltage) • Supply power to the EXT. I/O connector. No power needs to be supplied to the instrument.	p.83
		• Use the EXT. I/O test function to check the input and output signals.	p.95

Others

Symptom	Cause and solution		Reference
The power supply does not turn on.	• Power is not supplied.	• Check the continuity of the power cord. • Check that the facility main breaker is ON. • Turn ON the power supply switch (on the back).	p.28
	• The power supply voltage or frequency is not correct.	• Check the rating of the power supply. (100 V to 240 V, 50 Hz/60 Hz)	p.28
Key operations cannot be performed.	• [LOCK] is displayed. (Key lock)	• Release the key lock.	p.68
	• [ILOCK] is displayed. (Interlock)	• Turn ON the EXT. I/O interlock cancellation signal and release the interlock.	p.32
	• [RMT] is displayed. (Remote)	• Press the MENU key to cancel the remote state.	p.100
A contact check error occurs.	• The test lead is broken.	• Check the continuity of the test lead using a tester.	–
	• The test leads are not in contact with the DUT.	• Check the wiring.	–

10.3 Error

Error No.	Error description	Details	Solution	EXT. I/O error signal	Response of measurement status	Response to the error query (:SYSTEM:ERROR?)	Bit of the Status Byte Register (STB) to be set	Bit of the Standard Event Status Register (SESR) to be set	Clear by *CLS command
0	No error	There is no error.				0, "No Error"			
-100	Command error	The character string of the communications command is invalid.	Check that the command character string is correct.			-100, "Command error"	ERR	CME	
-200	Execution error	The communications command cannot be executed due to specific conditions.	The command cannot be executed under certain conditions.			-200, "Execution error"	ERR	EXE	
-220	Parameter error	The communications command parameters are out of the range or invalid.	Check the command parameter range or character string.			-220, "Parameter error"	ERR	EXE	
-316	Overheat error	An output circuit overheat event was detected, and output was stopped. Allow the instrument to cool.	Output will be possible 1 s after output stops.		20	-316, "Overheat error"	ERR	DDE	
-330	Self-test error	The result of the self-test (*TST?) was FAIL	Repair is necessary.			-330, "Self-test failed"	ERR	DDE	
-360	RS-232C communications error	A break signal was detected during RS-232C communications.				-360, "Communication error"	ERR	DDE	
-361	RS-232C parity error	A parity error occurs during RS-232C communications.	Check that the controller data length is 8 bits with no parity. Implement a noise countermeasure, such as attaching a ferrite core to the RS-232C line.			-361, "Rs232c Parity error"	ERR	DDE	
-362	RS-232C framing error	A framing error occurs during RS-232C communications.	Check that the controller data length is 8 bits with no parity. Implement a noise countermeasure, such as attaching a ferrite core to the RS-232C line.			-362, "Rs232c Framing error"	ERR	DDE	
-363	RS-232C overrun error	An overrun error occurs during RS-232C communications.	Reduce the data volume to be sent from the controller at one time. Change the RS-232C communications speed.			-363, "Rs232c overrun"	ERR	DDE	
-380	ROM error	A ROM error has been detected in a self-test at the startup.	Repair is necessary.	ON output	99	-380, "ROM error."	ERR	DDE	Not cleared
-381	RAM error	A RAM error has been detected in a self-test at the startup.	Repair is necessary.	ON output	99	-381, "RAM error."	ERR	DDE	Not cleared
-382	FRAM error	A FRAM error has been detected in a self-test at the startup.	Repair is necessary.	ON output	99	-382, "FRAM error."	ERR	DDE	Not cleared

Error No.	Error description	Details	Solution	EXT. I/O error signal	Response of measurement status	Response to the error query (:SYSTEM:ERROR?)	Bit of the Status Byte Register (STB) to be set	Bit of the Standard Event Status Register (SESR) to be set	Clear by *CLS command
-383	Internal temperature error (instrument error)	A temperature error occurred. The temperature is always monitored.	Turn back on the instrument and use the instrument within the operating temperature range. Repair is necessary even when the instrument is used in the operating temperature range but an error still occurs.	ON output	99	-383, "Temperature error"	ERR	DDE	Not cleared
-384	Output voltage error (hardware error)	Output of a voltage higher than the test voltage was detected during testing.	Turn off the instrument and remove the test leads. Turn on the instrument and perform a test. If you encounter an error, the instrument needs to be repaired.	ON output	99	-384, "Overvoltage error"	ERR	DDE	Not cleared
-385	Fan error (instrument error)	A fan error occurred. The fan is always monitored.	Repair is necessary.	ON output	99	-385, "Fan failed"	ERR	DDE	Not cleared
-387	Corrupted backup data (instrument error)	Damaged data is detected during a backup data check during the startup.	Repair is necessary.	ON output	99	-387, "Setting backup lost"	ERR	DDE	Not cleared
-388	Corrupted adjustment data (instrument error)	Damaged data was detected during an adjustment data check during the startup.	Repair is necessary.	ON output	99	-388, "Calibration memory lost"	ERR	DDE	Not cleared
-390	FPGA error (instrument error)	An error was detected during a communications check between the CPU and FPGA during the startup.	Repair is necessary.	ON output	99	-390, "FPGA failed"	ERR	DDE	Not cleared
-400	Query error	The transmission buffer was full when a communications command query was sent.	Be sure to receive a response when a query is sent.			-400, "Query error"	ERR	QYE	

10.4 License Information

The instrument uses the following open-source software.

Amazon FreeRTOS

Copyright (C) 2020 Amazon.com, Inc. or its affiliates. All Rights Reserved.

Permission is hereby granted, free of charge, to any person obtaining a copy of this software and associated documentation files (the "Software"), to deal in the Software without restriction, including without limitation the rights to use, copy, modify, merge, publish, distribute, sublicense, and/or sell copies of the Software, and to permit persons to whom the Software is furnished to do so, subject to the following conditions:

The above copyright notice and this permission notice shall be included in all copies or substantial portions of the Software.

THE SOFTWARE IS PROVIDED "AS IS", WITHOUT WARRANTY OF ANY KIND, EXPRESS OR IMPLIED, INCLUDING BUT NOT LIMITED TO THE WARRANTIES OF MERCHANTABILITY, FITNESS FOR A PARTICULAR PURPOSE AND NONINFRINGEMENT. IN NO EVENT SHALL THE AUTHORS OR COPYRIGHT HOLDERS BE LIABLE FOR ANY CLAIM, DAMAGES OR OTHER LIABILITY, WHETHER IN AN ACTION OF CONTRACT, TORT OR OTHERWISE, ARISING FROM, OUT OF OR IN CONNECTION WITH THE SOFTWARE OR THE USE OR OTHER DEALINGS IN THE SOFTWARE.

lwip

LwIP is licensed under the BSD license:

Copyright (c) 2001-2004 Swedish Institute of Computer Science.

All rights reserved.

Redistribution and use in source and binary forms, with or without modification, are permitted provided that the following conditions are met:

1. Redistributions of source code must retain the above copyright notice, this list of conditions and the following disclaimer.
2. Redistributions in binary form must reproduce the above copyright notice, this list of conditions and the following disclaimer in the documentation and/or other materials provided with the distribution.
3. The name of the author may not be used to endorse or promote products derived from this software without specific prior written permission.

THIS SOFTWARE IS PROVIDED BY THE AUTHOR "AS IS" AND ANY EXPRESS OR IMPLIED WARRANTIES, INCLUDING, BUT NOT LIMITED TO, THE IMPLIED WARRANTIES OF MERCHANTABILITY AND FITNESS FOR A PARTICULAR PURPOSE ARE DISCLAIMED. IN NO EVENT SHALL THE AUTHOR BE LIABLE FOR ANY DIRECT, INDIRECT, INCIDENTAL, SPECIAL, EXEMPLARY, OR CONSEQUENTIAL DAMAGES (INCLUDING, BUT NOT LIMITED TO, PROCUREMENT OF SUBSTITUTE GOODS OR SERVICES; LOSS OF USE, DATA, OR PROFITS; OR BUSINESS INTERRUPTION) HOWEVER CAUSED AND ON ANY THEORY OF LIABILITY, WHETHER IN CONTRACT, STRICT LIABILITY, OR TORT (INCLUDING NEGLIGENCE OR OTHERWISE) ARISING IN ANY WAY OUT OF THE USE OF THIS SOFTWARE, EVEN IF ADVISED OF THE POSSIBILITY OF SUCH DAMAGE

11 Appendix

11.1 Block Diagram

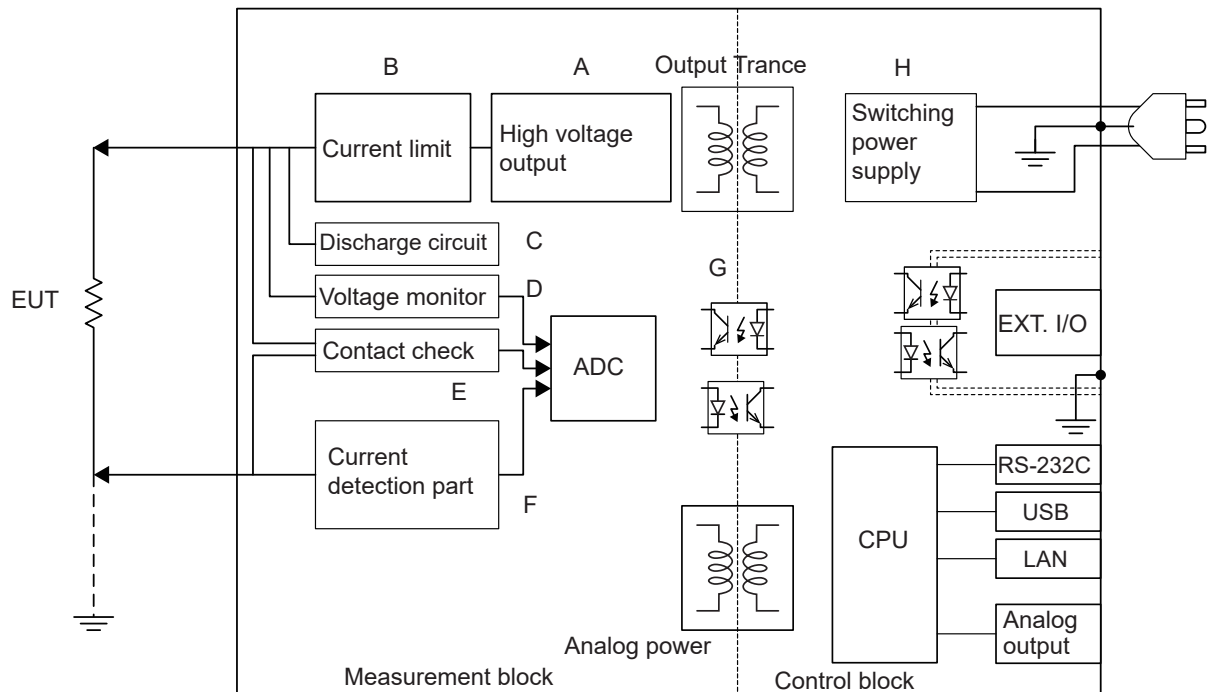

- (A) The unique technology mitigates the ripple and outputs the DC voltage without overshoots. The DC voltage can be changed between 25 V and 500 V with a resolution of 1 V.
- (B) The charging current and short circuit current can be set between 50 μA and 50 mA.
- (C) Any electric charge in the DUT can be discharged at a high speed.
- (D) The voltage monitor also operates even when a test is not being performed and the voltage between the measurement terminals can be monitored constantly. A BDD circuit is also included.
- (E) A contact check circuit is installed, which can improve the quality for an insulation resistance test.
- (F) Measurement current and BDD circuits are included.
- (G) The analog and digital units have a 500 V DC functional insulation structure and are equipped with a sufficient insulation capability.
- (H) A switching power supply with a wide input range between 100 V and 240 V is used for the power supply unit and stable measurement can be performed even in a poor power environment.

11.2 Current Limit and Relationship Between Measured Resistance and Output Voltage

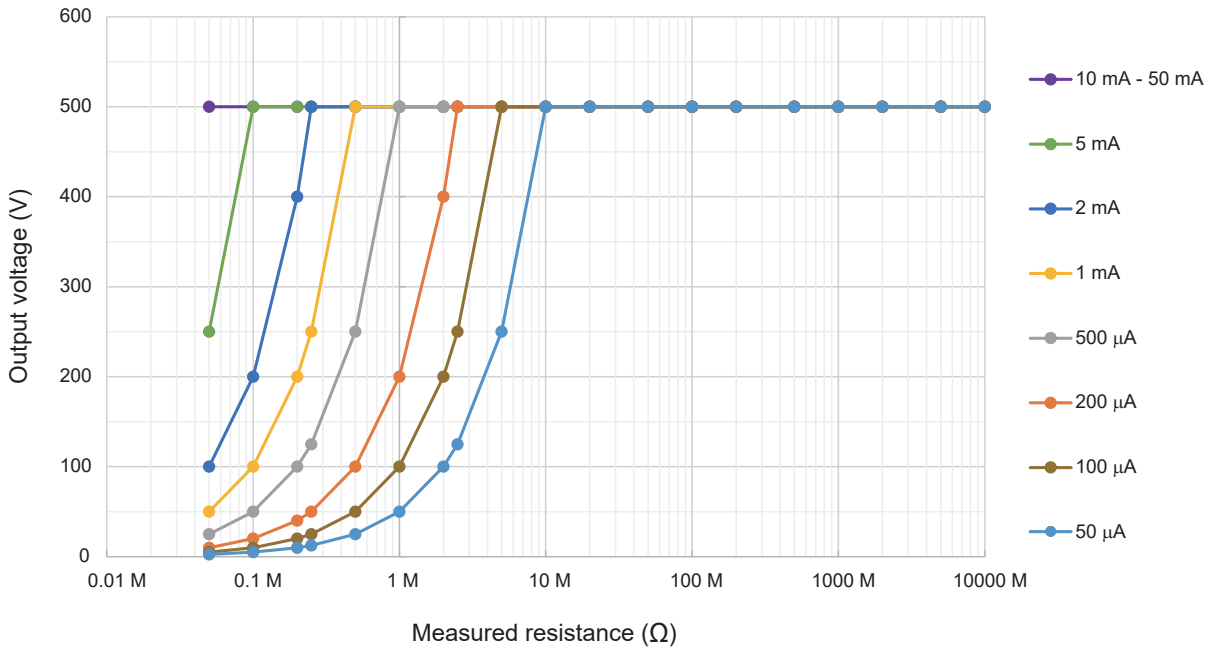

Output voltage depends on the set current limit value.

For a DUT that receives a measured current over the preset current limit value, the voltage does not go up to the set output voltage.

Example

If the test voltage is applied to a DUT with 1 MΩ after the current limit value is preset to 200 μA and test voltage to 500 V, the output voltage is calculated as follows. Due to this, the output voltage goes up only to approximately 200 V.

$$200 \mu\text{A} \times 1 \text{ M}\Omega = 200 \text{ V}$$

11.3 Influence of Capacitive Load

Pure resistance is assumed in the specifications of this instrument, however, the DUT contains considerable amount of capacitance. As a result of connecting a capacitive load, a greater inconsistency is found in the test data as the resistance is higher (small detection current) in general.

Influence on output voltage rise

The charging current can be set in the range between 50 μA and 50 mA.

When a capacitive load, such as a capacitor, is connected, the time required for the output voltage to rise is affected. The time required can be calculated as follows.

Output voltage rising time (s) = Capacitance value (F) \times test voltage (V) / current limit value (A)

Example

When a voltage is applied to a 0.1 μF capacitor at a test voltage of 500 V and current limit value of 2 mA, the time required for the voltage to rise to 500 V after the test starts is calculated as follows and is approximately 25 ms.

$$(0.1 \mu\text{F} \times 500 \text{ V}) / 2 \text{ mA}$$

IMPORTANT

- Depending on the DUT's capacitance component, the actual rising time may exceed the time calculated using the above equation. Set a sufficiently long test time.
- If a capacitive load of approximately 50 μF or more is connected while using a current limit value of 5.1 mA or more, constraints related to the output generator will result in an error, making measurement impossible.

See "9.2 Input, Output, and Measurement Specifications" (p. 180)

Repeatability

Measurement conditions

Connect the resistance load and capacitive load in parallel for measurement. (See the following figure.)

(Use a film capacitor as a capacitor.)

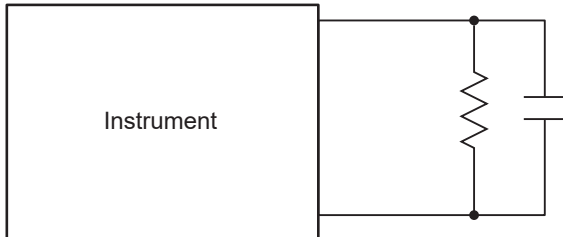

In the following test data, a capacitive load is connected and measurement is performed 100 times in the 200 MΩ range for each voltage value. The variation is calculated based on the average of the 100 measurements. The measured values are acquired with the capacitor charged.

(The test time is 100 seconds at most.)

Sampling time: 1 PLC

Voltage Capacitance	25 V	50 V	100 V	250 V	500 V
0.001 μF	±0.134%	±0.067%	±0.202%	±0.134%	±0.010%
0.01 μF	±0.202%	±0.135%	±0.270%	±0.135%	±0.067%
0.1 μF	±0.741%	±0.337%	±0.404%	±0.202%	±0.253%

IMPORTANT

The variation may be different depending on the capacitor type.

Cables used

LOW side	L2132 Unterminated Lead (red)
HIGH side	L2133 Unterminated Lead (black)

Instrument settings

Test voltage	100 V
Resistance range	2000 MΩ range
Load	1000 MΩ

Cable length Measurement speed	1 m	2 m	3 m	4 m	5 m
1 PLC	±0.2%	±0.1%	±0.3%	±0.3%	±0.3%

11.4 Influence of Noise

Noise transmission path

Electric disturbances in electric circuits and instruments are called noise.

Major noise sources at factories include motors, welding machines, and inverters.

Some electrical noise is transmitted directly from a noise source through communications, power, and grounding lines and other noise is transmitted by induction (static induction or electromagnetic induction).

See “Fig. Conductive noise transmission”.

The frequency band is wide and contains a surge, which is strong pulse noise. In addition, there is also electrical noise caused by the power supply frequency. The noise may affect the measured values.

Be aware that the measured values may be affected by electrical noise in the following cases.

- The measurement cable is placed near a noise source.
- The measurement cable is placed in parallel with the power supply line of a noise source.
- A power supply is shared with a noise source.

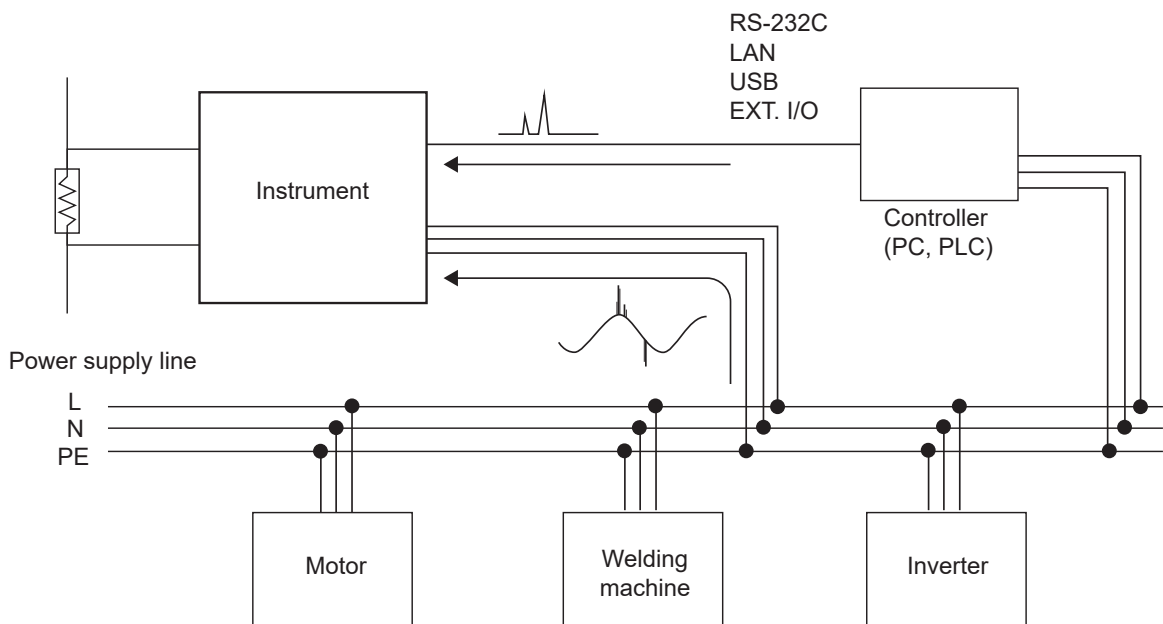

Fig. Conductive noise transmission

Precautions for measurement cable wiring

Pay attention to the following to mitigate the influence of noise on the measured values.

Keep the measurement cable away from the noise source and power supply line.

Signal lines are connected with conductive materials, such as metal, with stray capacitance.

Static induction noise is transmitted through this connection.

Since stray capacitance is inversely proportional to distance, a clearance from the noise source is required.

Ensure sufficient distance in the same manner between signal lines of different types, power supply and signal lines, input and output lines, and grounding and signal lines as well.

Synchronizing the sampling time with the commercial power supply frequency

The sampling time of this instrument is synchronized with the power supply frequency. When the main frequency setting of the supplied power is set to AUTO, 50 Hz or 60 Hz is automatically recognized and set. The main frequency can manually be set to 50 Hz or 60 Hz, however, be aware that the measured value becomes unstable if the setting is wrong.

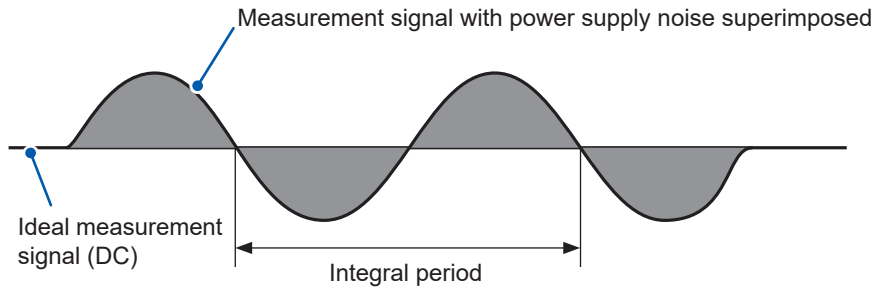

Noise caused by a commercial power supply

Separating the power supply line

It is recommended to prepare a separate power supply for power systems, welding machines, etc. See "Fig. Conductive noise countermeasure".

Insert a common mode filter (EMI choke) into the noise transmission path.

Select a common mode filter with high impedance, if possible. Multiple filters can increase the effect.

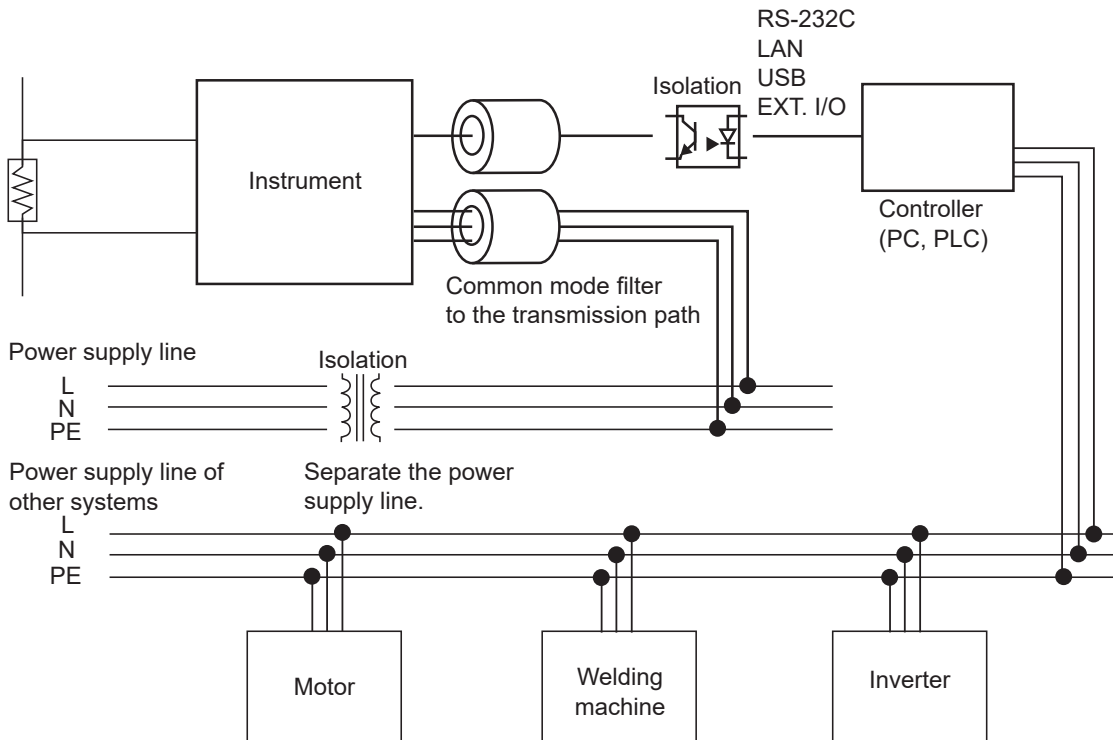

Conductive noise countermeasure

11.5 Change in the Current Flowing Through Insulators

When insulation resistance measurement is performed, a high current flows as soon as a voltage is applied, however, the current gradually drops and may not be stabilized.

This is due to charging current, absorption current, and leakage current and this condition is generally called dielectric absorption. The equivalent circuit with insulators is shown in Fig. 1 below. In this figure, a charging current flows through C_0 , C_1 , C_2 , and C_n when a voltage is applied. C_0 is charged first, then C_1 , C_2 , and C_n in that order. As the insulators are charged, the current becomes smaller and drops to the leakage current with R_0 at the end. (See Fig. 2.)

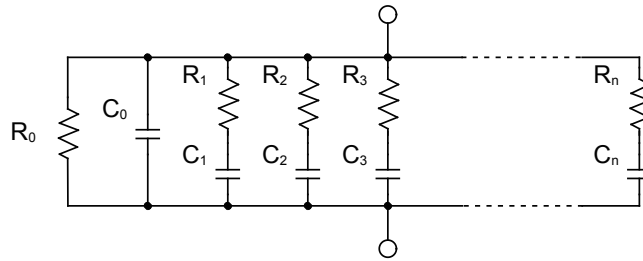

Fig. 1 Insulator equivalent circuit

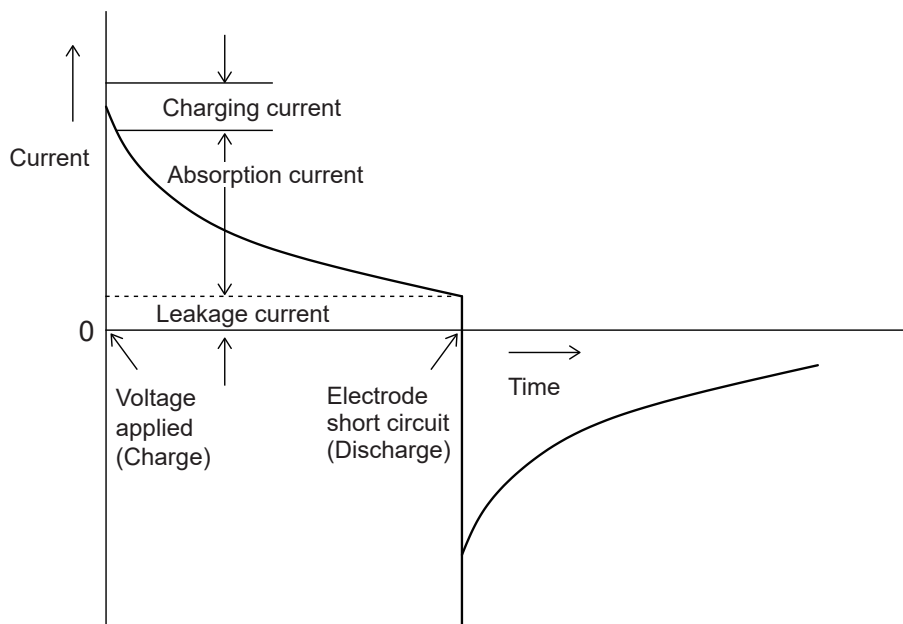

Fig. 2 Dielectric absorption

R_0 is the insulation resistance. Actually, high resistance R_1 , R_2 , and R_n are connected in series with C_1 , C_2 , and C_n and it is difficult to measure R_0 only.

In general, it is assumed that it takes a few hours to a few days for the measured value to stabilize. Therefore, the resistance value measured when 1 minute has elapsed after a voltage is applied is used as the insulation resistance of an insulator for convenience. This value is used widely for standards as a 1-minute value of the insulation resistance.

When a 1-minute value of the insulation resistance is measured, the initially measured value is different from the values of consecutive measurements. The DUT with a voltage applied needs to be fully discharged before measurement.

Depending on the magnitude of voltage " C_0 " in Fig. 1, generally a discharge time that is 5 to 6 times the time for which a voltage is applied during measurement is required.

11.6 LOW Terminal Side Test Lead Fabrication

When processing the tip of the Hioki LOW terminal side test lead, follow the order below.
 When stripping the coating and braided conductors, do not cut or short the test lead.

IMPORTANT
 The accuracy of a measured value acquired using a LOW terminal side test lead processed by a customer cannot be guaranteed.

Hioki LOW terminal side test lead shielded cable construction

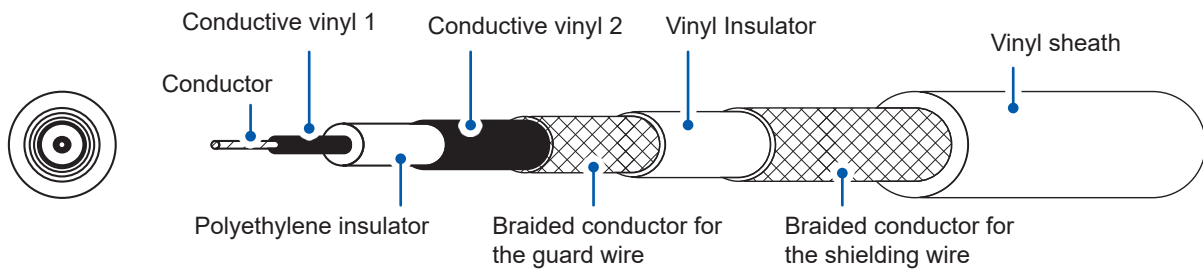

Item	Thickness (Approx.)	Diameter (Approx.)	
Conductor	–	0.54 mm	
Conductive vinyl 1	0.23 mm	1.00 mm	
Polyethylene insulator	0.85 mm	2.70 mm	
Conductive vinyl 2	0.22 mm	3.15 mm	
Braided conductor for the guard wire	0.25 mm	3.65 mm	
Vinyl Insulator	0.35 mm	4.35 mm	
Braided conductor for the shielding wire	0.25 mm	4.85 mm	
Vinyl sheath	1.05 mm	7.00 mm	+0.0 mm
			-0.2 mm

Processing the tip of the LOW terminal side test lead

Completion image

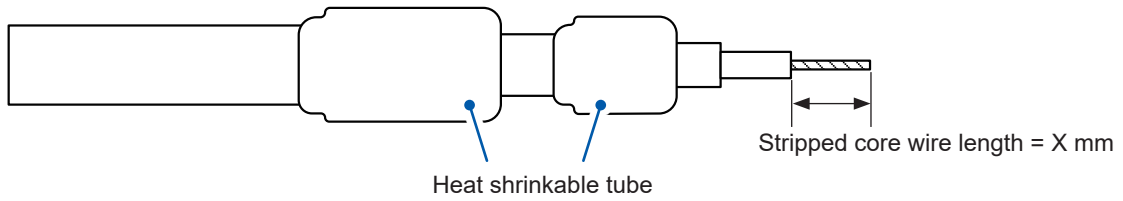

11

Appendix

1 Strip the coating using a knife, etc.

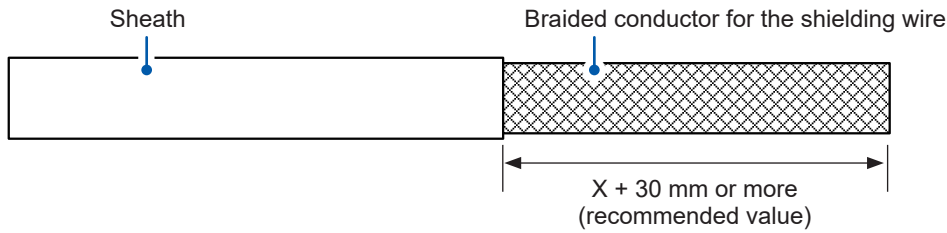

2 Fold back the braided conductor for the shielded cable.

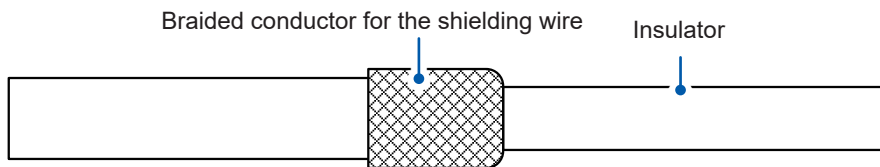

3 Remove the insulator using a knife, etc.

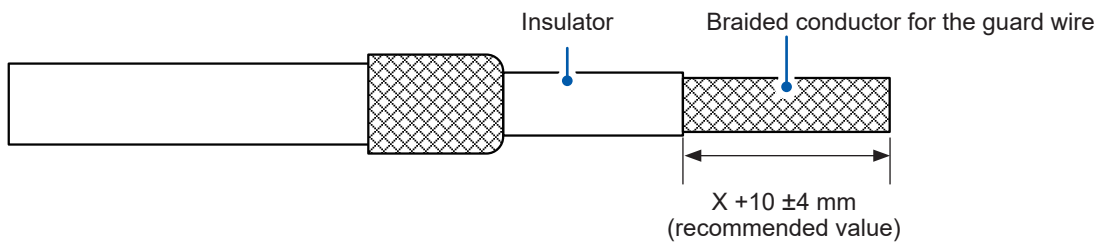

4 Fold back the braided conductor for the guard wire.

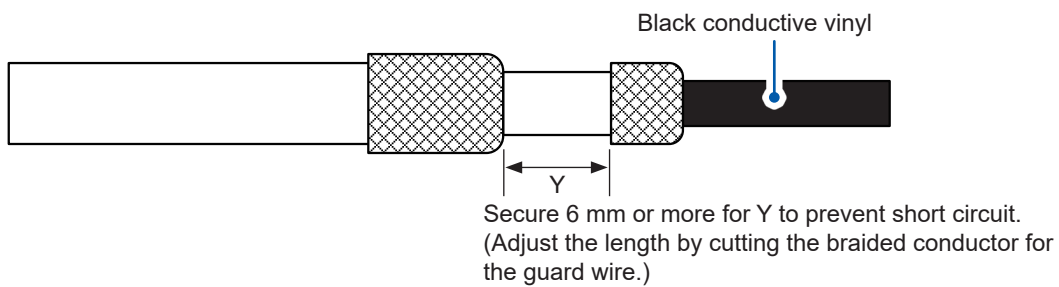

Take care not to short the shielded cable and guard wire.

5 Remove the conductive vinyl to the base.

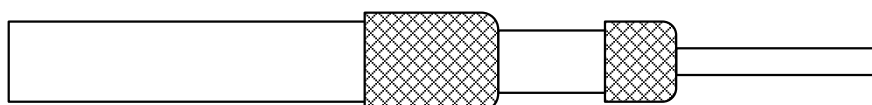

6 Remove the insulator using a knife, etc.

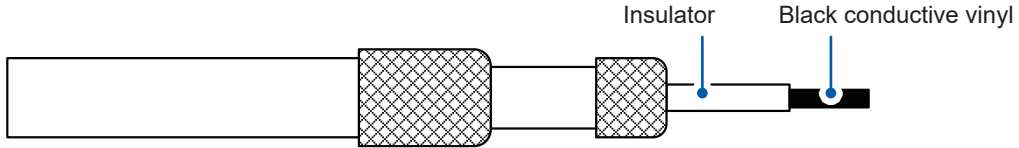

7 Remove the conductive vinyl to the base.

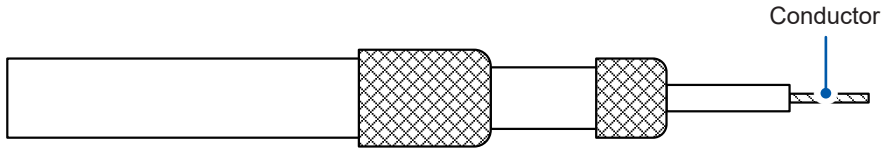

8 Place and shrink a heat shrinkable tube over the guard wire.

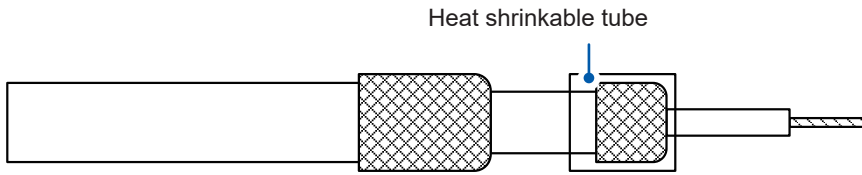

9 Place and shrink a heat shrinkable tube over the shielded cable.

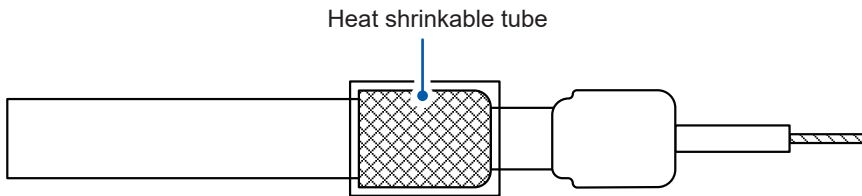

Complete



11.7 Rackmount Fittings

Rackmount fittings or the like can be attached to this instrument after removing the screws from the bottom.

⚠ WARNING

- Use specified screws to attach the fittings to the instrument main body.

(M4 × 8 mm binding head machine screw) *

* Use any M4 screw with a shaft length of at least 8 mm but no greater than 9.5 mm.



- When the rackmount fittings are reattached after removal from the instrument, reuse the screws that were initially used.

If fittings are attached with other screws, the instrument may be damaged, causing a risk of bodily injury.

If you lose or damage the screws, contact your authorized Hioki distributor or reseller.

Rackmount fitting reference drawing

Rackmount fitting (EIA)

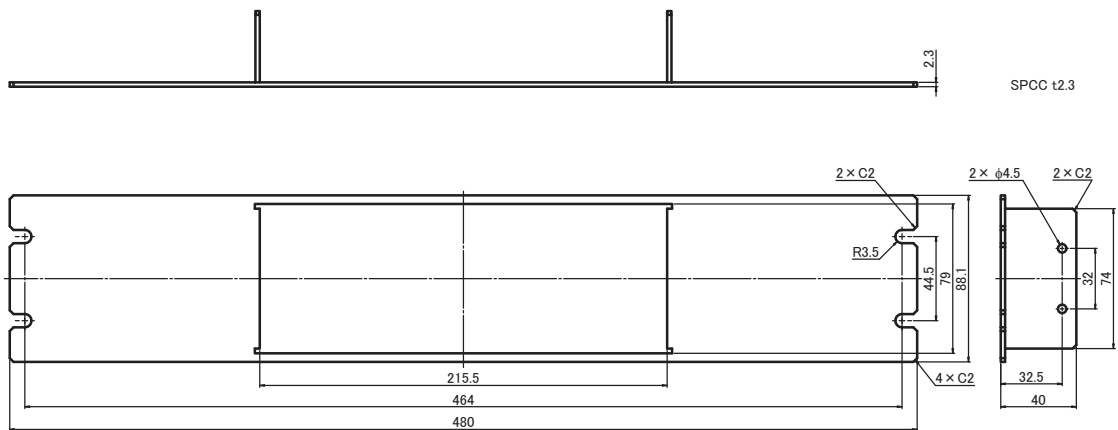

Rackmount fitting (JIS)

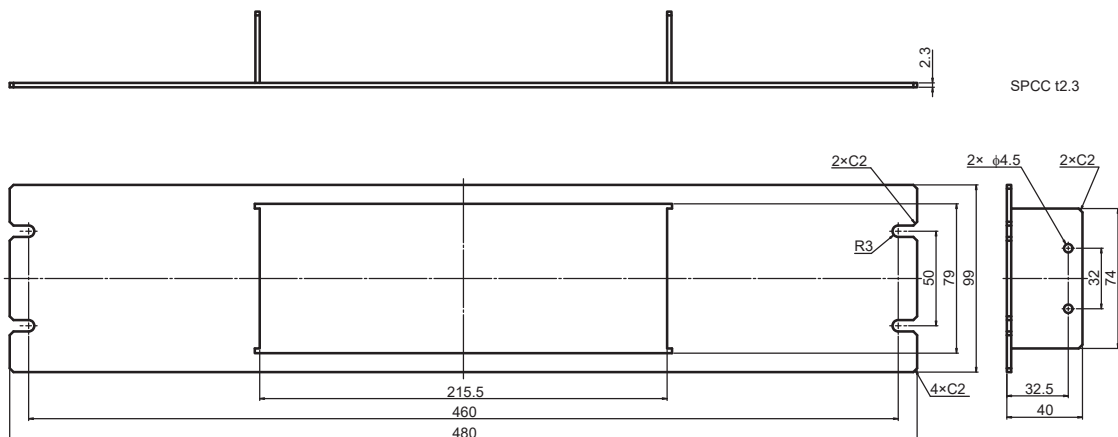

Spacer (2 pieces)

SPCC t1

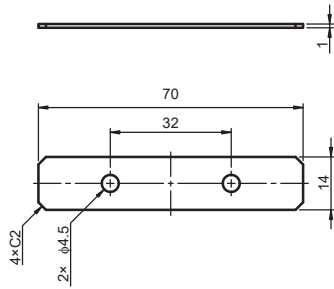

Rackmount fitting installation procedure

Tools to be prepared: Phillips screwdriver (No.2), rackmount fitting (EIA or JIS),
spacer ×2

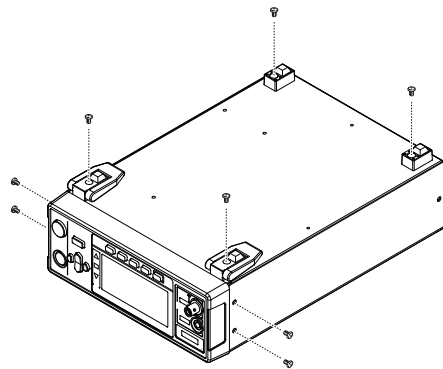

- 1** Place the bottom of the instrument facing up and remove the 8 screws from the support feet and sides.
- 2** Remove the support feet from the instrument.

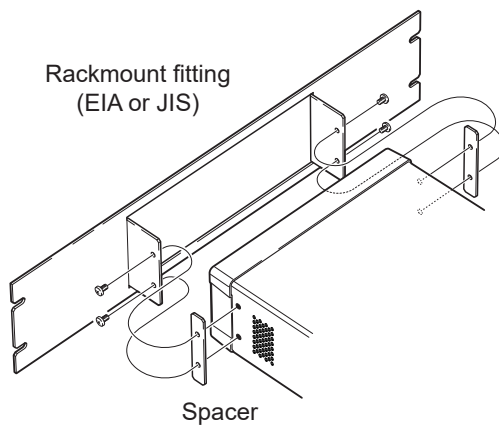

- 3** Attach the spacers to both sides of the instrument and secure the rackmount fitting using specified screws.
Keep the extra 4 screws.

IMPORTANT

- When installing the instrument on a rack, use a reinforcement stand, etc.
- Do not block the vent on the right side and rear side.

11.8 External View

(Unit: mm)

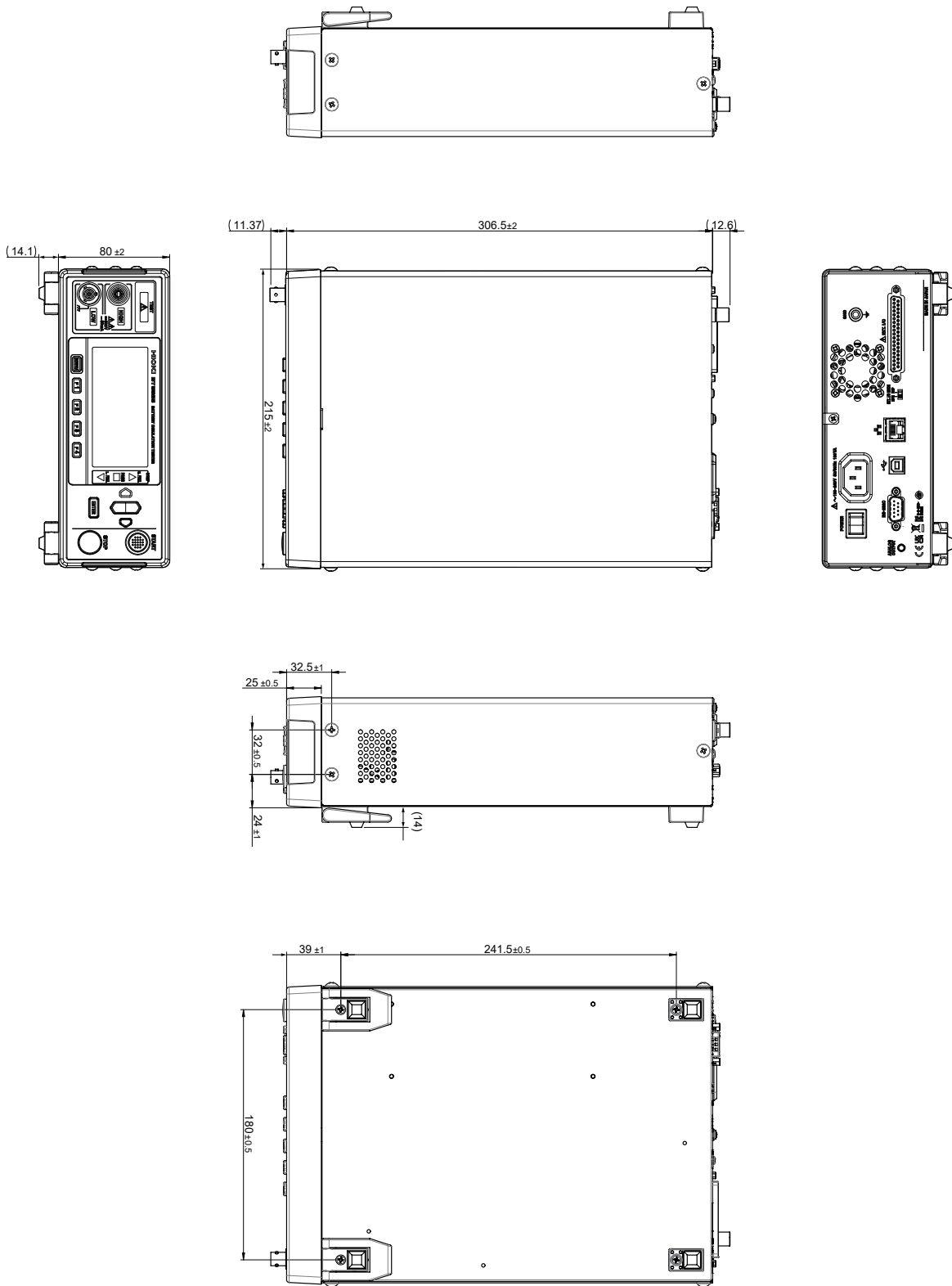

11.9 Default Setting

The instrument is set as follows at the time of shipment.

The settings with ✓ under setting backup are retained when the instrument is turned off.

When the instrument is initialized by reset, the settings with ✓ are restored to the default settings.

Panel save and load commands save or load settings indicated with a ✓ mark.

	Parameter	Default setting	Setting backup	Reset			Panel saving and loading
				System setting screen	:SYSTem:RESet	*RST	*SAV *RCL
Measurement (MEAS1)	Test voltage	25 V	✓	✓	✓	✓	✓
	Resistance Range	AUTO (2 MΩ)	✓	✓	✓	✓	✓
	Sampling time	1 PLC	✓	✓	✓	✓	✓
	Measurement delay time	1 PLC	✓	✓	✓	✓	✓
	Test time	OFF	✓	✓	✓	✓	✓
	Comparator delay time	AUTO	✓	✓	✓	✓	✓
	Test mode	CONTINUE	✓	✓	✓	✓	✓
	Judgment beep	FAIL	✓	✓	✓	✓	✓
	Judgment beep tone	TONE1	✓	✓	✓	✓	✓
Measurement (MEAS2)	Contact check	OFF	✓	✓	✓	✓	✓
	Judgment threshold value of the contact check	25.0 nF	✓	✓	✓	✓	✓
	BDD CC V	OFF	✓	✓	✓	✓	✓
	BDD CC V threshold value	1.0 V	✓	✓	✓	✓	✓
	BDD CV V	OFF	✓	✓	✓	✓	✓
	BDD CV V threshold value	1.0 V	✓	✓	✓	✓	✓
	BDD CV I	OFF	✓	✓	✓	✓	✓
	BDD CV I threshold value	1.0%	✓	✓	✓	✓	✓
	BDD stop function	OFF	✓	✓	✓	✓	✓
	BDD judgment	OFF	✓	✓	✓	✓	✓
	Current limit	MANUAL (2 mA)	✓	✓	✓	✓	✓
	Charging time	0.010 s	✓	✓	✓	✓	✓
Electrostatic capacitance value of the DUT	MANUAL (0.1 nF)	✓	✓	✓	✓	✓	
Comparator	Upper limit value	OFF	✓	✓	✓	✓	✓
	Lower limit value	OFF	✓	✓	✓	✓	✓
Panel (PANEL)	Panel 1 to 15	No panel save	✓	✓	✓		
System (SYS)	Beep for key input	ON	✓	✓	✓	✓	
	Key lock	OFF	✓	✓	✓	✓	
	Key lock passcode	OFF	✓	✓	✓	✓	
	LCD contrast	50	✓	✓	✓	✓	
	LCD backlight	2	✓	✓	✓	✓	
	Power supply frequency	AUTO	✓	✓	✓	✓	
Communications (IF)	RS-232C communications speed	9600 bps	✓	✓			
	IP address	192.168.1.1	✓	✓			
	Subnet mask	255.255.0.0	✓	✓			
	Default gateway	0.0.0.0	✓	✓			
	Communications command port number	23	✓	✓			
	Automatic data output	OFF	✓	✓			
	Command monitor	OFF	✓	✓			
Communications command-only settings	Response details of measured values (:MEASure:VALid)	4	✓	✓	✓	✓	
	Over-range value response (:MEASure:FORMat:OVER)	TYPE1	✓	✓	✓	✓	

For the initialization of each register, see “Items restored to the default settings” (p. 123).

For the procedure to reset on the System Setting screen, see “5.9 Initializing the Instrument (Reset)” (p. 75).

HIOKI
www.hioki.com/



**All regional
contact
information**

HEADQUARTERS

81 Koizumi
Ueda, Nagano 386-1192 Japan

HIOKI EUROPE GmbH

Helfmann-Park 2
65760 Eschborn, Germany
hioki@hioki.eu

2111 EN

Edited and published by HIOKI E.E. CORPORATION

Printed in Japan

- CE declarations of conformity can be downloaded from our website.
- Contents subject to change without notice.
- This document contains copyrighted content.
- It is prohibited to copy, reproduce, or modify the content of this document without permission.
- Company names, product names, etc. mentioned in this document are trademarks or registered trademarks of their respective companies.